



# Welcome to Pro Sound & Electrical's Lighting Catalog.

Over the past fifteen years, Pro Sound & Electrical has created many valuable relationships. Our commitment and dedication to manufacturing and distributing into the lighting industry has permitted PSE to grow at an enormous rate. Your continued response confirms that we exceed your expectations with outstanding performance.

We've learned that you deserve the best service and attention, a friendly knowledgeable staff, technical support, a large inventory selection, quality products and lastly, a competitive price. Achieving these has been our objective and reward. By focusing exclusively on lighting, we are able to lead in both innovative technology and superior customer support. Today, with wide variety and reliability, PSE supplies the needs of lighting professionals throughout the world. Pro Sound & Electrical will continue to strive for customer satisfaction and defining the lighting trends of the future.

Thank you!



Specifications are subject to change without notice.

## Index

- 1** Digital Lighting
- 7** Architectural Lighting
- 9** Moving Heads
- 15** Scanners
- 17** Followspots
- 19** Color Changers & Pin Spots
- 20** Par Cans
- 21** Film/Studio/T.V./Theatrical
- 23** Controllers
- 26** Consoles
- 27** Chasers/Switching
- 28** Dimmers
- 29** Interfaces & Accessories
- 30** Accessories
- 31** Fog Machines
- 32** Haze Machines
- 33** Fog & Haze Fluids
- 34** Strobe Lights
- 35** Special Effects
- 36** Specialty Lighting
- 37** Stands & Grip Equipment
- 37** Safety Cables
- 38** Motor Hoists & Clamps
- 40** Sandbags
- 40** Connectors & Cables
- 41** Power Connectors
- 42** Rope Lighting
- 43** Gobos
- 44** Expendables
- 46** Effect Lighting
- 49** Design Services

Acetates .....	19	Floor Base .....	37	Procell Batteries .....	45
Adapters .....	40	Fluorescent Soft .....	21	Protocol Convertor .....	29
Airwall Hanger .....	38	Fog Fluid.....	33	Raffaello .....	46
Alpha .....	47	Fog Machines .....	31	Reflectors .....	20
Alumalok.....	38	Fog Scents .....	33	Regia Consoles .....	26
Arena .....	18	Follow Spots .....	18	Rendering .....	49
Artist .....	23	Foot Controller .....	25	Ribalta .....	2,22
Bank Lights.....	22	Fresnels .....	22	Rope Lighting .....	42
Barndoors .....	20	Fusion .....	6	RotoGobo .....	43
Bates .....	41	Gaffer Tape.....	45	Safety Cables .....	37
Batteries .....	45	Galileo .....	16	Sandbags .....	40
Battens .....	3	Gel Tape .....	45	Scanners .....	15,16
Beacons .....	48	Gel .....	44	Scent Machine .....	35
Blacklights .....	36	Genio .....	9	Scents .....	33
Bubble Machine .....	35	Giotto .....	10,11	Shiva .....	15
Bulbs.....	44	Goblin .....	48	Shooter .....	48
Cables .....	40	Gobo Projector .....	43	ShowCad .....	23
Cam Connectors.....	42	Gobos .....	43	Sky Lights .....	46
Centerpieces .....	46,47	Gobo Holder .....	43	Smart .....	25
Chain Motors .....	38	Gooseneck Lights.....	30	Smoke Machines .....	31
Chasers .....	27	Grip Stands.....	37	Snow Machine .....	35
Cheeseboroughs .....	39	Haze Machines.....	32	Spacecraft .....	47
Chroma Fixtures .....	3-5	Hoists .....	38	Spaceflower .....	46
ChromaBank.....	3	Honeycomb .....	47	Socapex .....	42
City Color .....	7,8	Kaleidoscope .....	48	Splitter DMX .....	29
Clamps .....	39	Lamps.....	44	Stage Pin .....	41
Claw .....	39	LED Lights .....	1-6	Stands .....	37
Cobra .....	13	Light Dome .....	10	Starlight.....	47
Color Changers .....	19	Lighting Stands.....	37	Steady Kalima.....	47
Color Dynamic .....	19	Littlites .....	30	Strip Lights .....	22
Color Filters .....	44	Matte Wrap .....	45	Strobes .....	34
Colored Lenses .....	19	Mega Clamp .....	39	Switch Packs .....	27
Colormoon .....	48	MicroTech .....	29	Synthesis .....	12
ColorRGB .....	19	MicroUFO .....	48	Tapes .....	45
Commander .....	24	Mini City .....	7	Terminator.....	40
Connectors .....	40-42	Minibruf.....	22	Tie Line .....	45
Console Tape .....	45	Miniluz.....	22	Tie Wraps .....	45
Controller .....	23-25	Mirror Ball Motors .....	36	Tintoretto.....	46
Cool Lights .....	21	Mirror Balls .....	36	Touch Panel .....	25
CS .....	9	Mojo Scan.....	15	Topaz .....	27
Cyclorama Light .....	22	Mojo3 .....	47	Tracer .....	17
D/A Convertor.....	29	Moonball .....	48	Tracker .....	14
Data Cables .....	40	Moonlight .....	18	Treebar .....	28
Derby .....	48	Motor Controls .....	38	Trees.....	37
Design .....	49	Motor Hoists .....	38	Trick Line .....	45
Digi-Fan .....	35	Moving Heads .....	9-14	Trilly .....	47
Dimmer Packs .....	27,28	Mushroom/D .....	48	Tripods .....	37
DMX Controllers .....	23-25	Newton .....	17	Truss .....	37
DMX Master .....	24	Ocean .....	47	Truss Picks .....	39
Dominator .....	46	Operator .....	24	Tube Covers .....	44
Domingo .....	46	Oscillators .....	19	Tunnel Beam .....	47
Double Derby .....	48	Outstation .....	29	Twist Connectors .....	41
Duct Tape .....	45	Pack1 .....	27	Ultimate.....	32
Edison Plugs.....	41	Palco .....	1,2	Ultra-Gel .....	44
Effect Lighting .....	47,48	ParBar .....	20	UV Lights .....	36
Egg Strobe .....	34	ParCan Accessories .....	20	Victory.....	16
Electrical Tape .....	45	ParCans .....	20	Wind Tunnel .....	35
Elevator .....	37	Patterns .....	43	Windup .....	37
Elite .....	33	Pilot .....	25	Wireless DMX.....	29
Ellipsoidals .....	2	Pin-Spots .....	19	WYSIWYG.....	26,49
Expendables .....	44,45	Power Cables .....	40	XLR Connectors .....	40
Fan .....	35	Power Center .....	27	XS .....	13
Fastlock .....	39	PowerCon .....	41	Zip Ties .....	45
Filters .....	44				
Flame .....	35				
Flasher .....	34				
FlexiPar.....	20				

Organizations we or our staff are members of:





# PALCO 3 DL-PALCO3-X (X = Lens beam angle)

The Palco is a groundbreaking color-changing fixture for indoor and outdoor applications, which uses as its light source 49 high-power Luxeon LEDs. Palco creates an evenly diffused light beam, ideal for illuminating large areas. It has full DMX 512 control of all its main characteristics: luminous intensity, RGB color mixing, color temperature correction. The exclusive design, extremely compact lines and protection to IP65 make the Palco ideal for either permanent or temporary installation in a wide range of applications: monuments, buildings, stages, houses of worship, museums, art galleries, libraries, shopping malls, store window displays. Palco is also perfect for dynamically coloring backdrops and scenery in theatres, television and photography studios. Palco comes in three versions: Palco 3, Palco 3 White and Palco 3 Mobile



## FEATURES

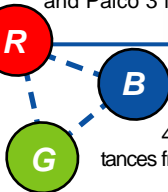

### >>> Interchangeable Lenses

Four Interchangeable lenses (8°, 25°, 40°, elliptical 10° x 22°) at various distances from the area being illuminated

### >>> Color & Color Temperature

Using a matrix of red, green and blue high power LEDs, additive color mixing is endless, from rich saturated to the coolest colors. Color temperature of the unit is 5500 kelvin and may be varied linearly.

### >>> Control & Menu

All functions are controllable via DMX using 8 channels. The 10 digit digital display allows for DMX addressing and all fixture settings.

### >>> Silent Operation

Totally silent, it does not use any type of forced ventilation. Palco is completely convection cooled by a rear heat sink. An electronic self-regulating internal temperature system ensures proper continuous operation even in extreme conditions.

### >>> Stand-Alone Operation

Completely programmable and operational without using any external controller. Can operate in master/slave mode with 1 master and 29 slaves. Independent programming of each unit is also possible. On-board weekly clock (7 day, 24 hour) function of 48 events. Clock playback scenes can occur gradually or instantly.

### >>> Installation

Palco has unique and stylish lines that enable it to discreetly fit into the surroundings and harmoniously adapt to the architectural elements which need to be lit. Palco may be floor or wall mounted by means of four screw holes on its base. It may also be flown from trussing using the included Fast-Lock pipe clamp. Once mounted, the head may be positioned by panning +/- 45 degrees, and tilted +15/-70 degrees.



### Specifications:

- LED color mixing RGB additive
- 3 watt LED
- 7 Luxeon Blue LEDs
- 18 Luxeon Green LEDs
- 24 Luxeon Red LEDs
- Luminosity (white) 2,800 Lumens
- Luminous power 100w
- Power Consumption 130w
- Color temperature: 5,500°K (variable)
- Interchangeable lenses: 8°, 25°, 40°, Elliptical 10 x 22° (comes with choice of one)
- LEDs average life: 100,000 hours
- Power: auto ranging 90-270vAC-50/60Hz
- 8 DMX Channels: 1-Strobe/Shutter, 2-Dimmer, 3-Red, 4-Green, 5-Blue, 6-CTC, 7-Macros, 8-Color Mode
- Interface LED 10 digit display & 3 buttons
- Internal Microcomputer Function menu (software updatable via DMX)
- Pan +/- 45° - manually positioned
- Tilt +15° / -70° - manually positioned
- Insulation rating: IP 65
- Size: (HxWxD) 16.73"x14.76"x9.02"
- Weight: 13.5Kgs/29.7Lbs

## ADVANTAGES OF LEDs

The use of LED technology offers numerous advantages:

- LEDs generate light that does not emit ultraviolet rays (which are potentially dangerous) nor infrared rays, thus preventing heat and reducing damage to the objects being illuminated.
- Electricity consumption is considerably lower than that of conventional light sources, and directly proportional to the intensity of the light emitted. LEDs high efficiency therefore result in a lower impact on the environment.
- LEDs operation life is approximately 100,000 hours at full power, with no noticeable variation in the quality of the light emitted; fixture maintenance costs are therefore extremely low.



## ADDITIONAL PALCO 3 LENSES

CODE	DESCRIPTION
DL-PALCO3LENS-25	Palco 3 Lens 25°
DL-PALCO3LENS-40	Palco 3 Lens 40°
DL-PALCO3LENS-8	Palco 3 Lens 8°

CODE	DESCRIPTION
DL-PALCO3-10X22H	Palco 3 LED Fixture - 10° x 22° Horizontal Lens - no plug
DL-PALCO3-10X22V	Palco 3 LED Fixture - 10° x 22° Vertical Lens - no plug
DL-PALCO3-40	Palco 3 LED Fixture - 40° Lens - no plug
DL-PALCO3-25	Palco 3 LED Fixture - 25° Lens - no plug
DL-PALCO3-8	Palco 3 LED Fixture - 8° Lens - no plug

# PALCO 3 WHITE

**DL-PALCO3W-X (X = Lens beam angle)**

LED lighting has become even more specialized with Palco 3 White Led. Thanks to this groundbreaking fixture, fitted with 7 Luxeon amber LEDs and 42 Luxeon white LEDs, it's now possible to accurately recreate the fluctuation and nuances of natural daylight. A valuable tool for any lighting designer who wants to reproduce sophisticated white light effects for indoor and outdoor applications, Palco 3 White LED is able to match any color temperatures, from the warmest to the coolest white, between 3,000°K and 10,000°K, by balancing the intensity of the LED groupings to the required levels.

This fixture is a combination of SGM high-tech expertise and all the typical features of the Palco 3, including the exceptional design and extraordinary luminosity.

For optimum installation flexibility, the unit's head can be removed from the rest of the body to allow for industry standard mounting.

- Specifications:** 7 Luxeon 3W Amber LEDs ■ 42 Luxeon 3W White LEDs ■ Luminosity 3,000 Lumens ■ Power Consumption 150w ■ Color temperature: 3,000-10,000 °K (variable) ■ No UV - Ultraviolet radiation ■ No IR - Infrared heat ■ Interchangeable lenses: 8°, 25°, 40°, Elliptical 10 x 22° vertical, Elliptical 10 x 22° horizontal ■ LEDs average life: 100,000 hours ■ Power: auto ranging 90-270vAC-50/60Hz ■ 4 DMX Channels: 1-Strobe/Shutter, 2-Dimmer, 3-White, 4-Amber ■ Interface LED 10 digit display & 3 buttons ■ Manual Fixed Pan +/- 45° on base ■ Manual Fixed Tilt +15°, - 70° on base ■ Insulation rating: IP 65 ■ Size: (HxWxD) 16.73"x14.76"x9.02" ■ Weight: 13.5Kgs/29.7Lbs ■ Color: black

CODE	DESCRIPTION
DL-PALCO3W-25	Palco White LED Fixture - 25° Lens - no plug
DL-PALCO3W-40	Palco White LED Fixture - 40° Lens - no plug
DL-PALCO3W-8	Palco White LED Fixture - 8° Lens - no plug



## PALCO 3 MOBILE

**DL-PALCO3M-X** (X = Lens beam angle)



PALCO 3 MOBILE includes all the features of PALCO: silent operation, efficient power consumption, high color rendering, exclusive design and extremely compact lines - plus the possibility of being positioned as required, thanks to its pan and tilt movement.

PALCO 3 MOBILE is fitted with absolute encoders so when reset doesn't run any repositioning procedure, it goes immediately to the required position. If accidentally moved, it restores the position and when switched off, a special mechanism enables to block the motor in the current position. Silent operation is guaranteed. PALCO MOBILE's qualities make it the right choice for replacing Halogen color changers with pan and tilt movement in all television and theater applications.

CODE	DESCRIPTION
DL-PALCO3M-25	Palco Mobile LED Fixture - 25° Lens - no plug
DL-PALCO3M-40	Palco Mobile LED Fixture - 40° Lens - no plug
DL-PALCO3M-8	Palco Mobile LED Fixture - 8° Lens - no plug

### Specifications:

- LED color mixing RGB additive
- 7 Luxeon 3W Blue LEDs
- 18 Luxeon 3W Green LEDs
- 24 Luxeon 1W Red LEDs
- Luminosity (white) 2,800 Lumens
- Power Consumption 160w
- Color temperature: 5,500°K (variable)
- Interchangeable lenses: 8°, 25°, 40°, Elliptical 10 x 22° (comes with choice of one)
- LEDs average life: 100,000 hours
- Power: auto ranging 90-270vAC-50/60Hz
- 13 DMX Channels: 1-Strobe/Shutter, 2-Dimmer, 3-Red, 4-Green, 5-Blue, 6-CTC, 7-Macros, 8-Color Mode, 9-Pan High Bit, 10-Pan Low Bit, 11-Tilt High Bit, 12-Tilt Low Bit, 13-Motor Speed
- Interface LED 10 digit display & 3 buttons
- Internal Microcomputer Function Menu (software updatable via DMX)
- Motorized Pan 0°- 305°
- Motorized Tilt 0°- 93°
- Insulation rating: IP 33
- Size: 19.1"x10.83"x9.02"
- Weight: 15.5Kgs/34.2Lbs

## RIBALTA

**DL-RIBALTA-X** (X = Lens beam angle)



### Specifications:

- LED color mixing RGB additive
- 30 Luxeon Blue 1W LEDs
- 30 Luxeon Green 3W LEDs
- 30 Luxeon Red 1W LEDs
- Luminosity 3,500 Lumens
- Power Consumption 180w
- Color temperature: 5,500°K (variable)
- Interchangeable lenses: 8° Asymmetric, 30° Asymmetric, Elliptical 10 x 90°
- LEDs average life: 100,000 hours
- Power: auto ranging 90-270vAC-50/60Hz
- 8 DMX Channels: 1-Strobe/Shutter, 2-Dimmer, 3-Red, 4-Green, 5-Blue, 6-CTC, 7-Macros, 8-Color Mode
- Interface LED display with 3 buttons
- Internal Microcomputer Function Menu (software updatable via DMX)
- Pan +/- 45°
- Tilt +15°, -70°
- Insulation rating: IP 65
- Size: 12.2"x38.2"x9.02"
- Weight: 16Kgs/35.3Lbs

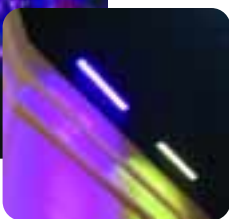

RIBALTA is an advanced color changing projector with 90 Luxeon LEDs, which enables the user to illuminate evenly with diffused light beams on large areas such as walls, theaters, TV studio backdrops, cyc curtains and architectural concepts. With the variety of lens choices, it is possible to locate the unit in many narrow areas and have a long throw alongside a near surface. The additional interchangeable lenses are asymmetric 8°, asymmetric 30° and, elliptical 10°x90°. The RIBALTA has top color efficiency. For example, the red's intensity is the same as that of a 750w halogen lamp source, but consumes less than 100w, an advantage of both low power consumption and high color rendering. Ribalta's IP65 rating makes it suitable for both indoor and outdoor use. It is quick and easy to install using two fastlock clamps or may be permanently mounted using hardware.



CODE	DESCRIPTION
DL-RIBALTA-8A	Ribalta LED Fixture - 8° Asymmetrical Lens
DL-RIBALTA-8	Ribalta LED Fixture - 8° Lens
DL-RIBALTA-40	Ribalta LED Fixture - 40° Lens
DL-RIBALTA-30A	Ribalta LED Fixture - 30° Asymmetrical Lens
DL-RIBALTA-25	Ribalta LED Fixture - 25° Lens



# CHROMABATTEN 50, 100, 200

Specifications are subject to change without notice.



**DL-PLCBAT50-X**  
**ChromaBatten 50**

- The ChromaBatten50 is a high-power LED fixture housed in a 300mm (1ft) IP65 linear enclosure
- Available with either 1W or 5mm LEDs
- 1W LED version contains 18 LEDs, 6 x 1 Watt RED, 6 x 3 Watt Green and 6 x 3 Watt Blue (Total 42 LED Watts) and is available in 8, 25, 45 and 12x25 degree beam angles
- 5mm LED version contains 243 LEDs, 75 x 5mm RED, 96 x 5mm Green and 72 x 5mm Blue and is available with a 20 degree beam angle
- Powered directly from Pulsar's ChromaZone12 or ChromaZone6 control system
- Expected 25,000 hour life at full power (estimated 100,000 hours when dimmed or color changing)

**Specifications:** High Power RGB LED Fixture - with 5m ChromaFlex Cable ■ Indoor, outdoor fixture ■ IP Rating: IP65 ■ Power: 4 units on ChromaZone12 ■ Size: 5.2"x11.8"x5.4" ■ Weight: 2.7kg/6Lbs ■ Color: Silver

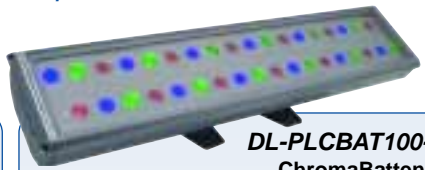

**DL-PLCBAT100-6-X**  
**ChromaBatten 100**

- The ChromaBatten100 is a high-power LED fixture housed in a 1.2m (4ft) or 600mm (2ft) IP65 linear enclosure.
- 36 LEDs, 12 x 1 Watt RED, 12 x 3 Watt Green and 12 x 3 Watt Blue (Total 84 Watts)
- Powered directly from 100-240 Volts AC 200 Watts maximum
- Full remote DMX control of RGB levels to allow endless colour mixing.
- LCD menu system for quick fixture configuration
- Internal sequences provide for operation without a separate control system.
- Available in 10 or 25 degree beam angles (more optional interchangeable lenses available soon)
- Expected 25,000 hour life at full power (estimated 100,000 hours when dimmed or color changing)

**Specifications:** RGB High Power LED Fixture ■ DMX512 via 5 pin XLR ■ Indoor, outdoor fixture ■ IP Rating: IP65 ■ Power: 100 - 240V, 50/60Hz ■ Size: 5.2"x23.6"x5.4" ■ Weight: 6.4kg/14Lbs ■ Color: Silver

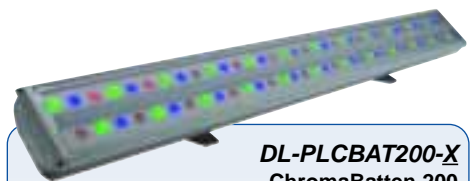

**DL-PLCBAT200-X**  
**ChromaBatten 200**

- The ChromaBatten200 is a high-power LED fixture housed in a 1.2m (4ft) IP65 linear enclosure.
- 72 LEDs, 24 x 1 Watt RED, 24 x 3 Watt Green and 24 x 3 Watt Blue (Total 168 Watts)
- Powered directly from 100-240 Volts AC 200 Watts maximum
- Full remote DMX control of RGB levels to allow endless colour mixing.
- LCD menu system for quick fixture configuration
- Internal sequences provide for operation without a separate control system.
- Available in 10 or 25 degree beam angles (more optional interchangeable lenses available soon)
- Expected 25,000 hour life at full power (estimated 100,000 hours when dimmed or color changing)

**Specifications:** RGB High Power LED Fixture ■ DMX512 via 5 pin XLR ■ Indoor, outdoor fixture ■ IP Rating: IP65 ■ Power: 100 - 240V, 50/60Hz ■ Size: 5.2"x47.2"x5.4" ■ Weight: 10.2kg/22.5Lbs ■ Color: Silver



**DL-PLCBAT17-45X25** ChromaBatten Flood LED 45°x25°  
**DL-PLCBAT17-20** ChromaBatten Flood LED 20°x20°

**Specifications:** Requires ChromaZone ■ 5m ChromaFlex Cable ■ Indoor, outdoor flood fixture ■ IP65 rating ■ Power: 12 units on ChromaZone12 ■ Size: 5.2"x7.72"x5.44" ■ Weight: 1.9kg/4.19Lbs ■ Color: Silver

## CHROMASTRIPX3

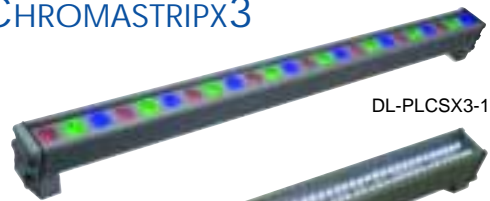

DL-PLCSX3-1W

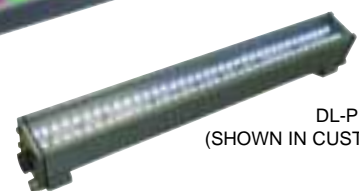

DL-PLCSX3-5MM  
(SHOWN IN CUSTOM WHITE)

ChromaStripX3 high power LED Strips provide three times the power of the CS2. They are finished in sleek extruded aluminum and available in four lengths. The ChromaStripX3 is waterproof and is available with either 1W/3W or 5mm LEDs.

ChromaStripX3 is ideal for highlighting architectural features such as windows, doorways, coves or building structure outlines and can also be used for linear illumination applications.

3W LEDs are used in 1W models to increase longevity and provide a powerful beam whereas the 5mm models produce improved close-up color mixing.

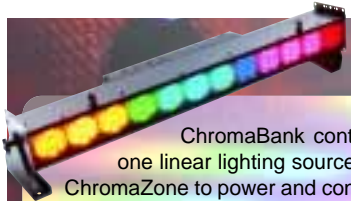

## CHROMA BANK MK2

**DL-PLCBANK2**

ChromaBank contains 12 ChromaHearts packaged together in one linear lighting source featuring a total of 960 LEDs. It has a built in ChromaZone to power and control the unit, offering numerous internal effects and chases that can operate in stand-alone mode or with an external DMX/PMX controller. The ChromaBank is also compatible with "video DMX" systems allowing the display of complex graphics and effects. The fixtures use very little power and generate minimal heat.

ChromaBanks are ideal for TV, Theatre and Stage applications providing incredible illumination and flexibility from a flicker-free LED based fixture.

The color wash effect is flawless on sets and cychs, and very effective when installed beneath glass floors or walls. It is also very impressive when hung from trusses allowing numerous strobing and chasing effects to be produced.

**Specifications:** Control input: DMX512 or PMX ■ Built-in Preset Games ■ Size: 51"x8.35"x9.06" ■ Weight: 10.5Kgs/23.10Lbs ■ Color: black

### Chroma Bank MK2 Flexible Lensing Configurations

The ChromaBank Mk2 is supplied with four Lens options to give the designer or user the ultimate flexibility for ChromaBank applications.

**Clear:** Providing a beam angle of 15x15 degrees this option is ideal for long distance use and daytime open air shows.

**Reeded:** With a horizontal of 20 degrees and a vertical angle of 90 degrees this Lens option is ideal for angle use.

**Frosted:** With a beam angle of 20x20 degrees this Lens is ideal for most applications and is fitted to the ChromaBank as standard

**QuadLightPipe:** The QuadLightPipe is a compact opal polycarbonate tube that combines the 12 ChromaHeart light sources together to produce a solid block of stunning color and an endless array of beautiful rainbow effects.

CODE	DESCRIPTION
DL-PLCSX3-1W	300 High power RGB LED Strip (12x1W LEDs 10°) ■ Size: 318mm/ 12.5"L ■ IP Rating: IP65
DL-PLCSX6-1W	600 High power RGB LED Strip (24x1W LEDs 10°) ■ Size: 614mm/ 24.2"L ■ IP Rating: IP65
DL-PLCSX9-1W	900 High power RGB LED Strip (36x1W LEDs 10°) ■ Size: 910mm/ 35.8"L ■ IP Rating: IP65
DL-PLCSX3-5MM	300 High power RGB LED Strip (72x5mm LEDs 10°) ■ Size: 318mm/ 12.5"L ■ IP Rating: IP65
DL-PLCSX6-5MM	600 High power RGB LED Strip (144x5mm LEDs 10°) ■ Size: 614mm/ 24.2"L ■ IP Rating: IP65
DL-PLCSX9-5MM	900 High power RGB LED Strip (216x5mm LEDs 10°) ■ Size: 910mm/ 35.8"L ■ IP Rating: IP65



**DL-PLCSTRIP12**  
**DL-PLCSTRIP9**  
**DL-PLCSTRIP6**  
**DL-PLCSTRIP3**



**DL-PLCPAR36**

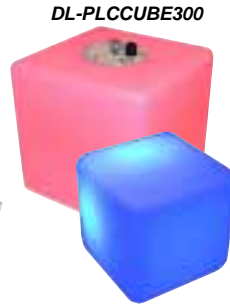

**DL-PLCCUBE150**



**DL-PLCDOME**



**DL-PLCSPHERE150**



**DL-PLCPEND**



**DL-PLCLIGHT**



Add an extra bracket to form the ChromaCrab!  
**DL-PLCDOME/B**



**DL-PLCSCAPE**



**DL-PLCFLUSH**



**DL-PLCPANEL6**  
**DL-PLCPANEL3**

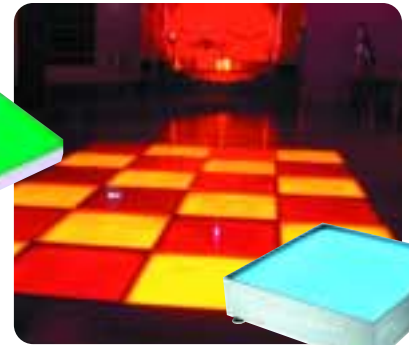

**DL-PLCDECK**

**DL-PLCFLEXG**  
 ChromaFlex

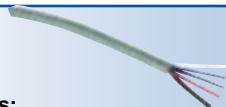

**Specifications:**

- 5 Core Multiway Cable Gray Per Meter
- Weight: .1kg/.22Lbs

Specifications are subject to change without notice.

ITEM NAME	ITEM NUMBER	DESCRIPTION	MR16 FIXTURE
ChromaAero Tube	DL-PLCCMR16AT	Stylish flush-mount w/accent	●
ChromaAngle Flush	DL-PLCCMR16AF	True flush mount	●
ChromaBirdie	DL-PLCBIRD1	Perfect for feature lighting, architectural apps.	●
ChromaBottle Washer	DL-PLCBOT	Lighting bottles on bar back	●
ChromaBump	DL-PLCCMR16BUMP	Flush mount with convex surface	●
ChromaCrystal Ball	DL-PLCCMR16CBALL	Striking eye-catching fixture	●
ChromaCrystal Column	DL-PLCCMR16CCOL	Color changing protrusion	●
ChromaCube 150	DL-PLCCUBE150	Smaller version of classic cube	●
ChromaFloor	DL-PLCMR16SS	Flush mount floor light	●
ChromaFrosted Eye	DL-PLCCMR16FEYE	Frosted flush mount	●
ChromaFrosted Tube	DL-PLCCMR16FT	Frosted protrusion	●
ChromaPendant (MR16)	DL-PLCCMR16PEND	Perfect for suspension over bar/table	●
ChromaScoop	DL-PLCCMR16SC	Adjustable flush mount	●
ChromaSearch	DL-PLCCMR16S	Mini searchlight style	●
ChromaSphere 150	DL-PLCSPHERE150	Smaller version of classic sphere	●
ChromaWall Ellipse	DL-PLCCMR16WE	Recessed flush fitting, low profile	●
ChromaWall Wash	DL-PLCCMR16WW	Boxed wall wash light	●
ChromaBank	DL-PLCBANK2	Theatre, TV, stage applications	
ChromaCube	DL-PLCCUBE300	Classic cube shape	
ChromaDeck	DL-PLCDECK	Dance floor color changer	
ChromaDome	DL-PLCDOME	Compact surface mount, adjustable	
ChromaFlush	DL-PLCFLUSH	Classic full size flush mount	
ChromaLight	DL-PLCLIGHT	Classic eyeball configuration	
ChromaPanel 600mm (23.63in)	DL-PLCPANEL6	Large light panel	
ChromaPanel 300mm (11.82in)	DL-PLCPANEL3	Small light panel	
ChromaPar36Can	DL-PLCPAR36	Classic PAR style fixture	
ChromaPendant	DL-PLCPEND	Perfect for suspension over tables or bars	
ChromaScape	DL-PLCSCAPE	Waterproof spotlights	
ChromaScape (stainless steel)	DL-PLCSCAPESS	Suitable for use in saline or chlorinated water	
ChromaSphere	DL-PLCSPHERE300	Classic sphere, full size	
ChromaStrip 1200mm (47.24in)	DL-PLCSTRIP12	20/90° RGB Tube	
ChromaStrip 900mm (35.44in)	DL-PLCSTRIP9	20/90° Linear strips of color mixing, multi-use	
ChromaStrip 600mm (23.63in)	DL-PLCSTRIP6	20/90° Linear strip, smaller length	
ChromaStrip 300mm (11.82in)	DL-PLCSTRIP3	20/90° Linear strip, short	
ChromaPSU2	DL-PLCPSU2	Power & control for 2 ChromaRange fixtures	
ChromaZone12	DL-PLCZONE12	Power & control for 12 ChromaRange fixtures	
ChromaZone6	DL-PLCZONE6	Power & control for 6 ChromaRange fixtures	

Specifications are subject to change without notice.



DL-PLCCMR16AT



DL-PLCCMR16AF



DL-PLCBIRDI

DL-PLCCMR16WE



DL-PLCCMR16BUMP



DL-PLC16CBALL



DL-PLCCMR16CCOL



DL-PLCCMR16FEYE



DL-PLCCMR16FT



DL-PLCCMR16SS

DL-PLCCMR16WW



DL-PLCCMR16PENC



DL-PLCACMR16SC



DL-PLCCMR16S



DL-PLCZONE12  
DL-PLCZONE6



DL-PLCBOT

	DIMENSIONS	WEIGHT	IP RATING	FINISH
	3.19"Dia x 2.84"D	.5kg/1.11Lbs		Brushed Nickel
	3.19" Dia x 2.05"D	.45kg/1Lbs		Chrome & Brushed Nickel
	4.14"W x 4.75"H	.4kg/0.89Lbs		Black or Silver
	4.10"Dia x 1.42"D	.25kg/0.56Lbs		White
	4.26"Dia x 3.23"D	.8kg/1.77Lbs		Silver Anodized
	5.57"Dia x 4.34"D	.8kg/1.77Lbs		Chrome Bezel & Claws
	3.23"Dia x 2.96"D	.5kg/1.11Lbs		Gold & Chrome Bezel
	5.91"W x 5.91"H x 5.91"D	1kg/2.21Lbs	IP65	
	4.14"Dia x 5.44"D <i>incl. ground mount</i>	1kg/2.21Lbs		Stainless Steel
	4.69"Dia x 3.63"D	.8kg/1.77Lbs		Frosted Glass
	3.19"Dia x 2.49"D	.5kg/1.11Lbs		Frosted Glass & Chrome Bezel
	4.77"Dia x 4.14"D	.7kg/1.55Lbs		Chrome
	3.94"Dia x 4.14"D	.65kg/1.44Lbs		White Paint
	4.14"Dia x 4.73"D	.5kg/1.11Lbs		Silver Paint
	5.91"Dia	.6kg/1.33Lbs	IP65	
	3.15"W x 21.26"H x 2.76"D	2kg/4.41Lbs		Silver Paint
	3"W x 3"H x 3.55"D	.5kg/1.11Lbs		Silver Paint
	50.99"L x 8.35"H x 9.06"D	10.5kg/23.15Lbs		Black
	11.82"W x 11.82"H x 11.82"D	2.5kg/5.52Lbs	IP65	
	24.02"W x 24.02"H x 6.97"-8.27"D	19.5kg/43Lbs		
	6.7"W x 5.52"D	.5kg/1.11Lbs		White, Black, Gold, Chrome, Silver, Primer
	6.5"Dia x 4.93"D	.5kg/1.11Lbs		White, Black, Gold, Chrome, Primer
	7.68"Dia x 4.59"D	.5kg/1.11Lbs		White, Black, Gold, Chrome, Silver, Primer
	23.23"W x 23.23"H x 2.96"D	5.2kg/11.47Lbs		
	11.54"W x 11.54"H x 2.96"D	1.7kg/3.75Lbs		
	6.5"W x 6.5"H x 9.14"D	.5kg/1.11Lbs		Polished Aluminum
	6.7"W x 5.52"H x 5.4"D	.84kg/1.86Lbs		Chrome
	6.15"Dia x 5.16"D	1.65kg/3.64Lbs	IP68	Black, White
	6.15"Dia x 5.16"D	1.65kg/3.64Lbs	IP68	Stainless Steel
	47.48"L x 1.58"Dia	1.5kg/3.31Lbs	IP65	Clear
	36.42"L x 1.58"Dia	1.3kg/2.87Lbs	IP65	Clear
	24.61"L x 1.58"Dia	1.1kg/2.43Lbs	IP65	Clear
	12.8"L x 1.58"Dia	.9kg/1.99Lbs	IP65	Clear
	5.12"W x 11.03"H x 2.56"D	1.7kg/3.73Lbs		
	8.27"W x 13.47"H x 2.76"D	2kg/4.41Lbs		
	8.27"W x 13.47"H x 2.76"D	2kg/4.41Lbs		



## LED PAR16 RGB LIGHT

**DL-PAR16RGB3/E26**

The PAR16RGB is the easiest and fastest way to add color lighting to any environment using the latest in LED color technology. Just screw it into any standard light socket and turn it on. PAR16RGB is a simple way to allow control and selection of 16 colors, 4 dimming levels and several color changing modes with no wiring. Simply point the IR remote and make your selection. Multiple units may either be set to same color or alternate colors as you desire to create any mood. Install and set a look in just minutes!!!



Applications: living or media rooms, restaurant dining areas, museums, hotel lobbies, ambient mood lighting in any room, haunted houses, theme park rides



**Specifications:** LEDs - 3 x 1w of Red, Green, Blue ■ Color system: RGB - 16 colors ■ Wattage: 3w ■ 4 levels of dimming ■ Base: Edison screw-in E26/E27 ■ Average led life: 10,000 hours ■ Front protection lens and rear heat sinking ■ Control using IR remote sold separately ■ Power: 90-230Vac 47/63 Hz ■ Power consumed: 5 watts ■ Weight: 0.10Kg/0.24Lbs ■ Size: 3.94"x1.97"Diameter ■ Color: White body/Silver chrome front

## RGB IR REMOTE

**CT-RGB3IR/RM**

Use the RGB IR REMOTE to control the PAR16RGB3 light fixtures. Just point it at the PAR16RGB3 lamps and make selection by pressing buttons to make quick changes.

**Specifications:** 31 total buttons ■ On/Off control ■ Selection of 16 colors with individual keys ■ Selection of 4 levels of dimming ■ Selection of fade modes ■ Allows lock & unlock for each fixture ■ Power: 2 x AAA Batteries ■ Weight: 0.10Kg/0.22Lbs ■ Size: 6.25"x2.38"x0.63" ■ Color: Black



## LED LIGHT TUBES

The Led RGB light tubes represents the most advanced animated light tubes available today. By merging Red, Green, and Blue LEDs, they create different kinds of effects including solid color change, individual pixel color chases, gradual and fast transitions, gray scale color levels, and graphical illumination effects. Led light tubes can be used for decorative, architectural, entertainment and themed applications, indoors and outdoors. The combination of many tubes can be used as scenic elements on stages to produce spectacular and unique visual effects. Tubes may be placed in straight runs or to form a wall matrix. These tubes can be connected in a daisy chain format (linked from one to the other). Each tube has 5 pin XLR connectors for input and output of data and separate connectors for power in and out. There are two sizes available: 0.5 and 1 meter.

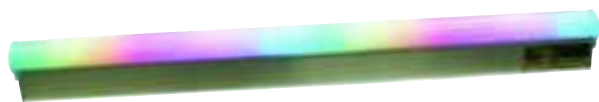
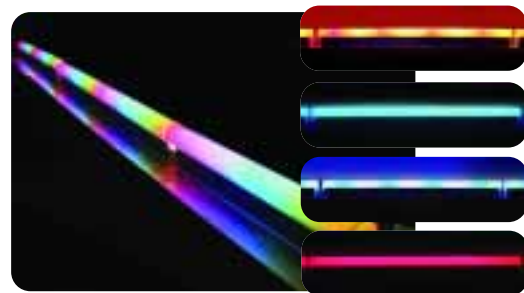

**DL-TUBERGB10/D**  
1 meter tube - 144 LEDs

**Specifications:** Housing: Aluminum & Opaque anti-UV tube ■ 16.8 watt ■ 48 Red, 48 Green, 48 Blue LEDs ■ Use CT-TUBERGB Controller ■ DMX512 using 49 channels maximum ■ Rating: IP65 ■ Mounting clips included ■ Power: 100-240vAC 50/60hz ■ Size: 39.5"x2"x3.75" ■ Weight: 1.73Kgs/3.8Lbs

**DL-TUBERGB05/D**  
0.5 meter tube - 72 LEDs



**Specifications:** Housing: Aluminum & Opaque anti-UV tube ■ 8.4 watt ■ 24 Red, 24 Green, 24 Blue LEDs ■ Use CT-TUBERGB Controller ■ DMX512 using 25 channels maximum ■ Rating: IP65 ■ Mounting clips included ■ Power: 100-240vAC 50/60hz ■ Size: 19.75"x2"x3.75" ■ Weight: 1.14Kgs/3.8Lbs

**LED Tube Controller**  
**CT-TUBERGB**

The RGB tube controller offers many modes of operation. It can run stand alone with hundreds of internal pre-built programs, speed and fade settings. Custom programs may also be create and stored, or it can run using a PC. Operates up to 5000 meters of the RGB tubes. A controller is needed to address tubes for DMX operation.

**Specifications:** Modes: PC, Set-up, Step Play, Auto Play ■ Control up to 5000 meters ■ Smart Media Card slot for 64mb storage ■ Power: 9v-12vDC, includes 120vAC wall adaptor ■ Size:7.25"x4"x2" ■ Weight: 0.6Kgs/1.3Lbs.



### Built-In Controller Effects:

- Static Color - Red, Green, Yellow, Blue, Purple, Cyan, White
- Slow Flow (unidirectional)
- Slow Flow (bi-directional)
- Roll Chase1 (rolling back and forth)
- Roll Chase2 (scan back and forth)
- Multi Color Chase (Rainbow)
- Fast Flow1
- Fast Flow2
- Two Color Chase
- Two Color Flow
- Gray Scale Color Change
- Dynamic Picture Effect

## LED PAR46 RGB DMX

**DL-PAR46RGB/B** Black  
**DL-PAR46RGB/W** White

The PAR46 LED RGB color mixing fixture can produce an unlimited array of colors. Fade from one color to the next, from a saturated RED to BLUE to GREEN and any color in between. This compact fixture offers the features of more expensive LED lights in an economical stylish plastic housing.

**Specifications:** Medium power RGB LED color mixing fixture using 90 large LEDs ■ 30 Red LEDs, 30 Blue LEDs, 30 Green LEDs ■ Control using DMX512 via 3 pin XLR connectors ■ Dip switch DMX addressing ■ 5 Channels of DMX ■ Standalone audio control using built microphone or internal modes ■ Adjustable input audio level ■ Fast action strobing or slow transition fades ■ Includes two plastic lenses: narrow beam clear & medium flood frosted ■ Adjustable U-bracket yoke with 1/2" clamp mount hole ■ Power: 100-240vAC50/60Hz ■ Current Draw: 0.2 Amps ■ Size: 7"x6.75"x6.75" ■ Weight: 0.91Kgs/2.02Lbs ■ Color: Black or White



## FUSION

**DL-FUSION**

The Fusion is a professional high power RGB LED color mixing projector with selectable beam angle optics. Allows the creation of millions of colors. It is suitable for industrial shows, theater, tradeshows and production use.

**Specifications:** High power LEDs - 18 x 3W ■ Color changer RGB system ■ Wattage: 54w ■ Current draw of less than 1 amp ■ Average led life: 100,000 hours ■ Efficient optical system ■ Beam angle options available by changing lenses: VN5P 6°, NSP 15°, WFL diffusion 68° x 55° ■ DMX512 using 5 channels ■ 5 pin XLR input ■ Power: 120Vac 50/60 Hz ■ Weight: 6.5Kg/14.33Lbs ■ Size: 14.8"x11.5"x16.3"





## CITY COLOR 400



### AR-CITYCOL400/2

#### Specifications:

- Lamps: 2 per unit, type CDM-T150W lamps, 3000k or 4200k
- Colors: Full CYM color mixing, unlimited variety of colors and shades  
Shutter & dimming function
- Beam angle (50%): 45 degrees
- Rating: IP 66
- Control Input: DMX512
- DMX channels: ch1-motor speed, 2-cyan, 3-yellow, 4-magenta, 5-dimmer, 6-macro colors/rainbow, 7-remote reset
- Configuration: setup using menu driven control panel
- Automode: Stand-alone & auto mode function for master/slave with 27 programs
- Power: 208-230v-50/60Hz with power factor correction
- Current draw: 2.4 amps
- Size: 18.9"x19.29"x29.13"
- Weight: 31Kgs/68.34Lbs

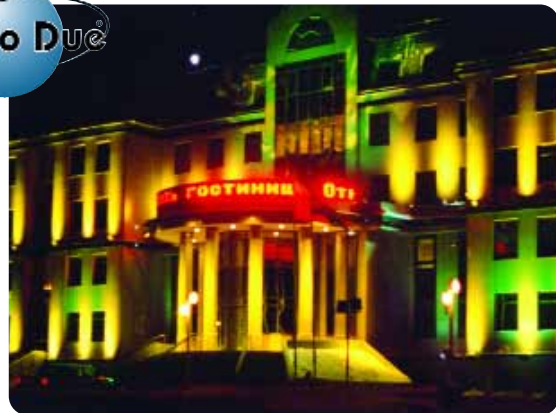

#### Lamp Selection:

	CDM-T150W/830	CDM-T150W/942
Color Temperature:	3000k	4200k
Average Life:	6000 hours	6000 hours
Luminous flux:	14,000 lumens	12,700 lumens
Burning position:	Universal	Universal

## CITY COLOR 300

### AR-CITYCOL300/2

#### Specifications:

- Lamps: 2 per unit, type CDM-T150W lamps, 3000k or 4200k
- Colors: Full CYM color mixing, unlimited variety of colors and shades
- Beam angle (50%): 45 degrees
- Rating: IP 66
- Control Input: DMX512
- DMX channels: ch1-motor speed, 2-cyan, 3-yellow, 4-magenta, 5-unused, 6-macro colors/rainbow, 7-remote reset
- Configuration: setup using internal dip switches
- Automode: Stand-alone & auto mode function for master/slave with 27 programs
- Power: 208-230v-50/60Hz with power factor correction
- Current draw: 2.4 amps
- Size: 18.9"x19.29"x29.13"
- Weight: 31Kgs/68.34Lbs



## MINI CITY 100, 150, 250

MiniCity is a series of medium power outdoor/indoor architectural fixtures. They come in a variety of wattages: 70, 150 and 250. By using an efficient optical and patented CYM color mixing system, these fixtures can create a smooth and unlimited assortment of colors and project with a wide coverage area. Cross-fading from one color to the other is seamless and can be gradual. All fixtures are IP66 rated for outdoor use.

### AR-MINICITY100/1

- Lamp: Discharge CDM-T70W/830 or CDM-T 70W/942 (PHILIPS)
- Color temperature: 3,000° k (CDM-T 70W/830) or 4,200°k (CDM-T 70W/942)
- Average lamp life: 12,000 hours
- Luminous flux: 6,600 lumens
- Burning position: Universal
- Full CYM color mixing, unlimited variety of colors and shades
- High resolution stepper motors
- Beam angle (50%): 20 degrees
- Rating: IP 66
- Control input: DMX 512
- 7 DMX channels: 1-motor speed, 2-cyan, 3-yellow, 4-magenta, 5-unused, 6-macro colors/rainbow, 7-remote reset
- Automode: Stand-alone control or auto mode master/slave with 27 programs
- Power: 117v-230v-50/60Hz (internal voltage selector)
- Current draw: 1.11 amps at 117v
- Size: 12.6"x12.4"x18.9"
- Weight: 10Kgs/22.05Lbs



### AR-MINICITY150S/2

- Lamp: Mastercolor CDM-T 150W/942 or CDM-T150W/830
- Average lamp life: 6000 hours
- Color temperature: 3,000° k (CDM-T 150W/830) or 4,200°k (CDM-T 150W/942)
- Luminous flux: 14,000 lumens
- Beam angle: (50%): 15 degree (on request parabolic for 28 deg wide beam)
- Full CYM color mixing, unlimited variety of colors and shades
- High resolution stepper motors
- Color crossfades can be programmed at four different speeds or in real time
- Rating: IP 66
- Shutter + Dimmer
- Control input: DMX 512
- 6 DMX channels: 1-motor speed, 2-cyan, 3-yellow, 4-magenta, 5-dimmer, 6-macro color
- Automode: Stand-alone control or auto mode master/slave with 27 programs
- Power: 230v-50/60Hz
- Current draw: 2.5 amps
- Size: 16.15"x8.27"x20.28"
- Weight: 13Kgs/28.67Lbs

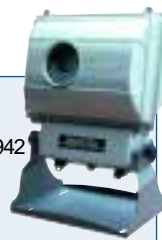

### AR-MINICITY250/1

- Lamp: discharge MSD250/2
- Average lamp life: 2000 hours
- Color temperature: 8500k
- Luminous flux: 18,000 lumens
- Rating: IP 66
- Beam angle: *motorized*  
-11 to 14 degrees with standard reflector  
-20 to 25 degrees with optional 28 degree wide parabolic reflector
- Full CYM color mixing unlimited variety of colors and shades
- High resolution stepper motors
- Shutter + Dimmer
- Configuration of settings via display control panel
- Control input: DMX 512
- 7 DMX channels: 1-motor speed, 2-cyan, 3-yellow, 4-magenta, 5-dimmer, 6-beam angle, 7-remote reset / lamp
- Automode: Stand-alone control or auto mode master/slave with 27 programs
- Power: 120v-50/60Hz
- Current draw: 3 amps
- Size: 17.32"x8.66"x22.83"
- Weight: 18Kgs/39.68Lbs



## CITY COLOR 1800 & 2500

**AR-CITYCOL1800**  
**AR-CITYCOL2500**

City Color is a high power outdoor/indoor wash fixture. It is available in two versions, an 1800 and a 2500 watt. Both units are IP54 rated for outdoor exposure and feature efficient optical systems. The City Color uses an internationally patented CYM color mixing system which produces even color when lighting very spread out surfaces. An endless number of colors can be created and fading from one color to another is seamless. Its on board control panel and display allow the user to set the fixture's many functions and check running hours of the unit and lamp life. The cooling system is controlled by a microprocessor and together with the thermal switch guarantee a perfect operating temperature with very little maintenance required; often the only service needed is lamp replacement. The unit can run in stand alone mode with built in scene programs and can master/slave with other units. DMX can be used to individually control each function and synchronize multiple units.



**AR-CITYCOL2500**

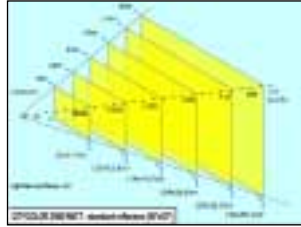
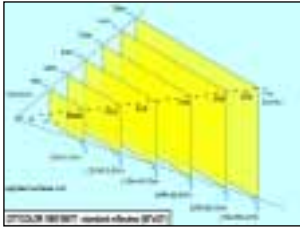

**General Specifications:**

- IP rating: 54
- Beam angle: 50 x 52 degrees
- Color mixing: full CYM using high resolution stepper motors
- Dimmer: 0-100% mechanical
- 7 DMX Channels: ch1-motor speed, 2-cyan, 3-yellow, 4-magenta, 5-dimmer, 6-color macros, 7-remote reset / lamp off
- Automode: stand-alone master/slave function with 27 built-in programs
- Power: 208-220-230-240vAC - 50/60Hz, with power factor correction
- Size: 30.7"x22.05"x29.13"

	<b>AR-CITYCOL1800</b>	<b>AR-CITYCOL2500</b>
■ <b>Lamp:</b>	LMHN1800-P	HMD2500 - MHN-SA2500w
■ <b>Lamp life:</b>	average 2500 hours	average 2000 hours
■ <b>Color temperature:</b>	5600 degrees Kelvin	6000 degrees Kelvin
■ <b>Luminous flux:</b>	180,000 lumens	260,000 lumens
■ <b>Current draw:</b>	10 Amps	14 Amps
■ <b>Weight:</b>	55Kgs/121.26Lbs	67Kgs/147.7Lbs



**AR-CITYCOL1800**

**AR-CITYCOLBARN**

City Color Barn Doors  
Four leaf barn doors are available to help control and define the illumination area on the City Color units. This barn door attaches directly on to the front of the fixture.



## CITY BEAM 1800

**AR-CITYBEA1800**

City Beam 1800 is an IP rated outdoor fixture for illuminating large areas from a long throw distance. Its efficient optical system is controlled by stepper motors and can produce a variable beam angle from 5 to 8 degrees and 11 to 14 degrees with the diffuser.

The IP54 rated version unit offers an intuitive display menu control panel and a microprocessor controlled cooling system. The control circuits and the thermal switch guarantee a perfect operating temperature making maintenance an infrequent event. Usually the only service required is lamp replacement. Fixture and lamp hours are also displayed on the control panel.

**Specifications:**

- IP rating: 54
- Lamp: LMSR2000SA-P
- Lamp life: average 750 hours
- Color temperature: 5600 degrees kelvin
- Luminous flux: 150,000 lumens
- Remote beam angle control: 5 to 8 degrees, with diffuser: 11 to 14 degrees
- Color mixing: full CYM using high resolution stepper motors
- Dimmer: 0-100% mechanical
- Shutter
- 7 DMX Channels: ch1-motor speed, 2-cyan, 3-yellow, 4-magenta, 5-dimmer, 6-beam angle, 7-remote reset / lamp off
- Automode: stand-alone master/slave function with 27 built-in programs
- Power: 208-230vAC-50/60Hz, with power factor correction
- Current draw: 11 Amps
- Size: 30.7"x22.05"x29.13"
- Weight: 51Kgs/112.4Lbs



**AR-CITYBEA1800**

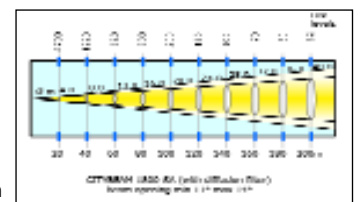
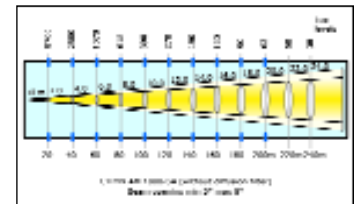



Specifications are subject to change without notice.



# GENIO MOBILE

## DL-GENIOM-X

GENIO MOBILE is a compact, stylish color-changing projector that uses new LED technology to produce unlimited colors. 16 high-power Luxeon LEDs enable it to generate a diffused even light beam. Furthermore, the beam of light may be aimed and moved by the motorized pan & tilt functions. Its movements are virtually silent.

The GENIO MOBILE is totally silent; the fixture is convection cooled by means of its rear finning, and an electronic self regulating internal temperature system to ensure continuous operation.

GENIO MOBILE was designed and built for the countless situations in which design, agility and compact dimensions are required. Applications range from sales outlets, art galleries, television studios, theaters and night clubs. GENIO MOBILE is suitable for indoor and outdoor operation, as it's protected to an IP65 rating.

### Specifications:

- LED color mixing RGB additive
- 4 Luxeon Blue 1W LEDs
- 8 Luxeon Green 3W LEDs
- 4 Luxeon Red 1W LEDs
- Luminosity 1,800 Lumens
- Power Consumption 180W
- Color temperature: 5,000°K (variable)
- Interchangeable lenses: 8°, 25°, 40°
- LEDs average life: 100,000 hours
- Power: auto ranging 90-270vAC-50/60Hz
- 13 DMX Channels: 1-Strobe/Shutter, 2-Dimmer, 3-Red, 4-Green, 5-Blue, 6-CTC, 7-Macros, 8-Color Mode, 9-Pan H, 10-Pan L, 11-Tilt H, 12-Tilt L, 13-Motor Speed
- Interface LED display 3 buttons
- Internal Microcomputer Function Menu (software updatable via DMX)
- Pan 540°
- Tilt 270°
- Insulation rating: IP 65
- Size: 9.5"x10.2"x11.8"
- Weight: 6.5Kgs/35.3Lbs



CODE	DESCRIPTION
DL-GENIOM-8	Genio Mobile LED Fixture - 8 Degree Lens - no plug
DL-GENIOM-40	Genio Mobile LED Fixture - 40 Degree Lens - no plug
DL-GENIOM-25	Genio Mobile LED Fixture - 25 Degree Lens - no plug

# STUDIO DUE CS LINE



The CS2 and CS4 are all around multipurpose multipars that provide you with a solution to any lighting design dilemma you'll come across. Studio Due has designed two simple, elegant, and brilliant lighting fixtures that add a dramatic element to your shows and venues. They're made up of either two or four ACL PAR cans that Pan independently of each other. The entire "bar" Tilts as one unit, and can be mounted either horizontally or vertically (or diagonally, if you're really good at rigging). Thanks to their compact design, the CS2 and CS4 add the perfect amount of eye candy to smaller venues that don't have the space or budget for a more elaborate lighting rig. However, both units fit right in with larger staging events and installations, and add a completely unique look to the show. If you haven't found the answer to your lighting challenge yet, give the CS units a try!



CS4  
IL-CS4



CS2  
IL-CS2



### Specifications:

- Lamps: ST 250W 28V or GE4552 250W 28V
- Lamp life: ST 250W - 300 hours/GE4552 - 50 hours
- Movement: stepper motor 8 or 16 bit resolution
- Pan/Tilt: single tilt 200/multiple pan 270
- Control: RS-485 DMX 512
- 20 DMX channels
- Built-in microprocessor with display
- Power: 100V/120V/230V 50/60Hz
- Power draw: CS2- 550W CS4- 1100W
- Current draw: CS2- 2.4 amps (230V) CS4- 4.8 amps (230V)
- Electronic progressive dimmer
- Size: CS2- 39.38"x11.82"x17.72" CS4- 78.79"x11.82"x17.72"
- Weight: CS2- 19Kg/41.89Lbs CS4- 31Kg/68.35Lbs

# SGM GIOTTO SERIES



## GIOTTO 400 SPOT CMY

**IL-GIOTTO400SCMY/B**

The GIOTTO SPOT 400 CMY is the latest addition to the Giotto 400 Series of moving light fixtures, designed for use in high-profile entertainment applications, in concerts, theatres and television studios. GIOTTO SPOT 400 CMY offers the most advanced features in its class, including a 400w hot re-strikeable MSR lamp source, 9°-24° motorized zoom, advanced CMY color generation mixing system + 1 color wheel with 6 dichroic colors and open, 2 rotating indexable gobo wheels and an animation wheel. In addition the fixture features a linear iris, linear frost, linear CTO filter, 1 rotating prism and an electronic flicker free ballast. GIOTTO SPOT 400 CMY was designed paying great attention to noise levels, silent operation and cooling being a key priority for houses of worship, theatre and television studio applications. The Giotto series is virtually silent. The head movement and the fixture's internal mechanism also have an extremely low noise level. A phonometric test done by Istituto Giordano S.p.a. in an anechoic chamber shows a noise level of only 31.8dB at 1 meter. Its unique cooling system is a hybrid between convection cooling and forced ventilation. Thanks to the thermal interface of the dichroic reflector with a metal heat sink, heat is dispersed towards the rear of the fixture and two very low-speed variable fans ensure sufficient air circulation for perfect fixture operation even when in high surrounding temperatures up to 122 degrees. GIOTTO SPOT 400 CMY is powerful and versatile, yet compact and lightweight; the fixture can be easily transported and installed by a single person, thanks to the rugged and practical handles and 'Fast Lock' hanging clamps. When both the brightness of bigger lamp units and the size of a small projector is needed, the GIOTTO SPOT 400 CMY is the ideal choice!



tion and cooling being a key priority for houses of worship, theatre and television studio applications. The Giotto series is virtually silent. The head movement and the fixture's internal mechanism also have an extremely low noise level. A phonometric test done by Istituto Giordano S.p.a. in an anechoic chamber shows a noise level of only 31.8dB at 1 meter. Its unique cooling system is a hybrid between convection cooling and forced ventilation. Thanks to the thermal interface of the dichroic reflector with a metal heat sink, heat is dispersed towards the rear of the fixture and two very low-speed variable fans ensure sufficient air circulation for perfect fixture operation even when in high surrounding temperatures up to 122 degrees. GIOTTO SPOT 400 CMY is powerful and versatile, yet compact and lightweight; the fixture can be easily transported and installed by a single person, thanks to the rugged and practical handles and 'Fast Lock' hanging clamps. When both the brightness of bigger lamp units and the size of a small projector is needed, the GIOTTO SPOT 400 CMY is the ideal choice!

**Specifications:** Lamp: MSR400HR (6,000k) ■ Average lamp life: 750 hours ■ Luminous power: 12,000 Lux at 5 m ■ Automatic lamp re-strike ■ Remote lamp on/off via DMX ■ Lamp power attenuation in the event of overheating or when shuttered ■ Lamp hour timer and strike meter ■ Fixture operation time meter ■ Motorized zoom (9°-24°) ■ Motorized focus ■ CMY color mixing ■ Color wheel: 6 colors + white (interchangeable) ■ Linear color filter ■ 2 Gobo wheels: 8 rotating indexable and interchangeable gobos each ■ Animation wheel (interchangeable) ■ 2-tone color beam splits ■ Color change with music sync and/or blackout ■ Continuous color wheel rotation ■ UV light effect filter ■ Variable frost ■ Gobo change with music sync and/or blackout ■ 1 rotating prism (4-facet) ■ Variable iris ■ Variable dimmer ■ Shutter ■ Strobe (1-12 flashes per second even with music sync) ■ Pan 540° (2.8 sec.) ■ Tilt 270° (1.7 sec.) ■ 8/16 bit resolution ■ Auto Pan/Tilt repositioning and correction ■ Microprocessor controlled setting using digital display panel ■ Display "flip" function (180° rotation) ■ Dimmable display lighting ■ Fast-Lock clamping system ■ Control input: DMX512 ■ 34 DMX channels ■ Automatic energy saving when the fixture is blacked out ■ Power: electronic ballast universal 90-245v-50/60Hz ■ Current draw: 7 amps ■ Size: 29.28"x14.38"x16.23" ■ Weight: 33Kgs/72.8Lbs ■ Colors: black or white

### GIOTTO 400 SPOT

### GIOTTO 400 WASH

### GIOTTO 400 PROFILE



**IL-GIOTTO400S/W**  
(IL-GIOTTO400S/B for black)



**IL-GIOTTO400W/B**  
(IL-GIOTTO400W/W for white)



**IL-GIOTTO400P**



Giotto 400 rotating shutters



Giotto 400 Profile shaper



## LIGHT DOME

### AC-LIGHTDOME



This is a cover designed by SGM for outdoor application when using Galileo II 1200, Galileo IV 1200 fixtures and Giotto 400. The dome is highly transparent heat-resistant polycarbonate with a built-in ventilation system and ABS body. Fixtures housed in the dome are protected against weather, vandalism and attempted theft. Domes are available in two standard colors: grey and blue. On request, custom colors are also available for orders of at least 10 units.

**Specifications:** ■ Power: 220V AC 50/60Hz 30w ■ Size: 39.37"x31.5"x 31.5" ■ Weight: 20 Kgs/44.09Lbs

Specifications are subject to change without notice.



# GIOTTO 400 FIXTURE SPECIFICATIONS



Specifications are subject to change without notice.

	Spot	Wash	Profile	Spot CMY
Product code	IL-GIOTTO400S	IL-GIOTTO400W	IL-GIOTTO400P	IL-GIOTTO400S/CMY
Silent Operation	■	■	■	■
Lamp	MSR400HR	MSR400HR	MSR400HR	MSR400HR
Luminous power	12,000 Lux at 5m	12,000 Lux at 5m	12,000 Lux at 5m	12,000 Lux at 5m
Color Temperature	6000K	6000K	6000K	6000K
Lamp Life (hours)	750	750	750	750
Automatic hot re-strike	■	■	■	■
Remote lamp on/off via DMX	■	■	■	■
Lamp power reduction in case of overheat	■	■	■	■
Lamp elapsed time and strike meter	■	■	■	■
Fixture operating time meter	■	■	■	■
Motorized linear zoom	9°-24°	19°-38°	16°-24°	9°-2
Motorized remote focus	■	■	■	■
CMY color mixing	■	■	■	■
3,200° K color conversion filter (full CTO)	■	■	■	■
4,000° K color conversion filter (half CTO)	■	■	■	■
Linear color conversion filter	■	■	■	■
Blacklight (UV) filter	■	■	■	■
Color wheel (customizable)	8 colors +white	7 colors +white	8 colors +white	6 colors +white(interchangeable)
Effect wheel (customizable)	■	■	■	■
Rainbow effect (Color wheel rotation)	■	■	■	■
Color change w/music sync and/or blackout	■	■	■	■
Gobo change w/music sync and/or blackout	■	■	■	■
2-tone beam (color splits)	■	■	■	■
Variable frost	■	■	■	■
Fixed gobos	4	■	■	■
Indexable rotating gobos	48	■	■	■
Gobo size metal: OD/ID	30mm/24mm	■	30mm/24mm	30mm/24mm
Gobo size glass: OD/ID	28mm/24mm	■	28mm/24mm	28mm/24mm
Rotating prism	2	■	■	1 (4-facet)
Animation wheel (interchangeable)	■	■	■	■
Variable iris	■	■	■	■
Strobe: 1-12 fps with music sync	■	■	■	■
Shutter	■	■	■	■
Internal rotating shutters (0°-180°)	■	■	■	■
Internal rotating shaper	■	■	■	■
Linear 0 -100% dimmer	■	■	■	■
Pan 540° and Tilt 270° (speed)	(2.8s) (1.7s)	(2.8s) (1.7s)	(2.8s) (1.7s)	(2.8s) (1.7s)
Automatic Pan/Tilt position correction	■	■	■	■
8/16 bit resolution	■	■	■	■
Power Factor Correction	■	■	■	■
Auto energy saving when blacked out	■	■	■	■
Setting via built-in microcomputer	■	■	■	■
Adjustable display brightness	■	■	■	■
Fast-lock clamping system	■	■	■	■
Display "flip" function (rotation by 180°)	■	■	■	■
Input signal: DMX 512 channels:	22	18	27	34
Electronic ballast	■	■	■	■
Power Consumption:	600w	600w	600w	7amps
Universal voltage input	100-245V 50/60Hz	100-245V 50/60Hz	100-245V 50/60Hz	90-245V 50/60Hz
Size:	26.81" x 14.37" x 16.22"	26.81" x 14.37" x 16.22"	26.81" x 14.37" x 16.22"	29.28" x 14.38" x 16.23" x
Weight: Kgs/Lbs.	24.8/54.7	24.8/54.7	24.8/54.7	33/72.8
Approvals	ETL / CE	ETL / CE	CE	CE

# GIOTTO SYNTHESIS

IL-GIOTTOSYN/S



## SYNTHESIS

- Wireless DMX
- Modular Construction
- 360° Positionable Animation Wheel
- 700 Watt Single Ended Lamp
- Advanced CMY Color Mixing
- Automatic Hot Restrike
- 5600°k or 7200°k Lamp Temperature



The Giotto Synthesis is the absolute latest in moving light technology. It's the first moving light to be equipped standard with truly wireless DMX, so you finally have the freedom to program and control your lights from more complicated locations than regular DMX cables will allow. Another innovative feature is a three-segment modular construction, making your repair issues that much easier by letting you swap out and send in for repair only part of a fixture instead of the fixture itself. And because the Synthesis is so unique, SGM has worked closely with Osram to create two specific lamps with two separate color temperatures (5600°K and 7200°K) to better resolve any color temperature issues you have.

SGM has also responded to the issues of rigorous touring with two new solutions. The first is a unique Pan/Tilt locking and electronic unlocking system, ensuring that your locked fixtures can always be unlocked once connected to a power source (even when already hung on truss). The second is secure protection against power surges of 380V, a common problem in Europe that has fried many lighting fixtures over time.

Of course, some of the best features of the Synthesis are the ones you can see in action! SGM has created a "revolutionary" positionable animation wheel that rotates on a 360 degree axis, allowing for more creative animation options in your lighting designs. The dual Spot/Wash projection feature adds to the Synthesis's versatility, practically giving you two separate fixtures in one. Along with the Spot/Wash capabilities, the Synthesis has both the infinite palette of CMY color mixing and the precision of 6 interchangeable spot colors. Dual gobo wheels that can each hold eight 16-bit rotating, indexable, interchangeable gobos give you plenty of options for high quality graphic and atmospheric projections, and a 4-facet rotating prism gives you another fun feature to play with. All of the Synthesis's features are an addition to the already extensive features of all Giotto range fixtures, which include the exclusive use of hot re-strike lamps and the silent operation that has made the Giottos a standard in the industry. And because of all of this, the Synthesis is the perfect moving light for everywhere from theatrical installations to major tours.

### Specifications:

Lamp: HTI 700/w-SE (7200°K) or HTI 700/w-SE (5600°K)  
 ■ Lamp life: 500 hours ■ Luminous power: 38,750 Lux ■ Automatic lamp re-strike ■ Remote lamp on/off via DMX  
 ■ Lamp power attenuation in the event of overheating ■ Lamp elapsed time and strike meter ■ Fixture operating time meter ■ Internal temperature (base, head) meter ■ Motorized zoom (9°-32°) ■ Motorized focus ■ Twin projection: Spot and Wash ■ Linear frost ■ CMY color mixing  
 ■ Color wheel: 6 colors + open (interchangeable) ■ Linear CTO/CTB ■ 2 Gobo wheels: 8 rotating, indexable, interchangeable gobos each (16 bit) ■ Gobo/color change with music sync and/or blackout ■ Animation wheel (interchangeable): indexable, 360° rotation and revolution ■ 2-tone color beam splits ■ Color scrolling ■ UV filter ■ 1 rotating prism (4 facet) ■ Variable iris ■ Variable dimmer ■ Shutter ■ Strobe (1-12 flashes per second & music sync) ■ Pan 540° (4 sec.) ■ Tilt 270° (3.4 sec.) ■ Pan/Tilt lock: auto electric unlock ■ 8/16 bit resolution ■ Auto Pan/Tilt repositioning ■ Electronic ballast ■ Hi-res graphics display (140x16) ■ Settings via internal microcomputer indicated on display, even when fixture turned off ■ Display "flip" function (180° rotation) ■ Dimmable display lighting ■ DMX 512 and RS 232 input signal ■ 35 DMX channels ■ Ethernet interface (ACN protocol) ■ DMX wireless interface ■ RDM protocol implemented on DMX for monitoring internal parameters ■ Auto energy save when fixture blacked out ■ Power supply with PFC: universal - 90/240V 50/60Hz; 380V protected ■ Power consumption: 1000W ■ Modular construction ■ Size: 29.53"x15.75"x18.12" ■ Weight: 38Kg/83.78Lbs

## MODULAR CONSTRUCTION

- Sophisticated Features
- Quick & Easy Access
- Rugged Design







## XS1200 *IL-XS1200*

The XS1200 encompasses every modern feature in one moving light. Its powerful output makes it perfect for long throw applications like TV studios, sports arenas, theatres and concerts. The optical system of condenser lenses and dichroic mirror reflector is the heart of the projector's luminous output. Remote focus and zoom have been added as well, resulting in the ability to create a vast amount of spectacular effects.



### Specifications:

- Lamp: HTI1200W/D7/60 or MSI1200DE
- Lamp life: average 750 hours
- Color temperature: 6000 degree Kelvin
- Luminous flux: 110,000 lumens
- Remote Lamp: control on/off by DMX
- Movement resolution: 16 bit
- Pan: 460 degrees
- Tilt: 270 degrees
- Pan/Tilt auto encoder positioning and correction
- Color Wheel 1: 5 dichroic colors + 6 bi-colors and color scrolling
- Color Wheel 2: 3 dichroic colors + 3 bi-colors
- Conversion Filters: CTO and CTB
- Gobo Wheel 1: 5 gobos plus open, rotating and indexable
- Gobo Wheel 2: 5 gobos plus open, rotating and indexable
- Static Gobos: 3 glass gobos

- Dimming: Electronically from 100 to 60%, mechanically from 60% to 0.
- Shutter & Strobe: 1-15 flashes per second
- Zoom: motorized 17 to 27 degrees
- Focus: motorized, from 1 meter to infinity
- Prisms: 2 rotating
- Iris: motorized from open to close
- Frost: 2 softening filters + 1 continuous frost
- Display: microprocessor controlled menu
- Graphic LCD display with flip function
- Control Input Signal: DMX512 - opto-isolated in/out
- Color: black
- Power: 95-260v-47/63Hz with power factor correction, electronic power supply
- Size: 17.13"x17.13"x25.2"
- Weight: 32Kgs/70.55Lbs
- DMX Channels: 20 channel control

- ch1 = iris
- ch2 = color
- ch3 = gobo wheel 1
- ch4 = strobe/shutter
- ch5 = pan coarse
- ch6 = pan fine
- ch7 = tilt coarse
- ch8 = tilt fine
- ch9 = dimmer
- ch10 = motor speed
- ch11 = focus
- ch12 = filters
- ch13 = gobo wheel 2
- ch14 = gobo wheel 2 position index/rotation
- ch15 = gobo wheel 1 position index/rotation
- ch16 = zoom
- ch17 = glasses
- ch18 = frost
- ch19 = prisms
- ch20 = reset / lamp off / pan & tilt ramp

## COBRA 150

### IL-COBRA150S/1

The Cobra 150 is our smallest single arm automated moving-head with 11 brilliant dichroic colors, 7 rotating gobos and a fast mechanical shutter for strobing effects. Its long life HSD150/70 watt type discharge lamp and quick pan/tilt action make this the perfect fixture for mobile DJs, small nightclubs, and store displays.

### Specifications:

- Lamp: HSD 150/70
- Color temperature: 7000K
- 3 Element coated lens system
- Beam angle: 21 degrees
- Light Output: 2,350 lumens
- Manual focus
- Operating focal distance: minimum 6' to infinity
- Gobo wheel: 7 rotating gobos + open
- Bidirectional and variable speed gobo rotation
- Color wheel: 11 dichroic colors + open and split colors
- Variable bidirectional continuous color wheel spin
- Mechanical dimmer 0-100%
- Shutter/strobe function
- Pan and Tilt with feedback auto position correction
- Pan/Tilt Resolution 16-bit
- Pan/Tilt invert
- Hall effect sensors for all effect resets
- Stepper motors for all effects
- DMX512 control input using 3-Pin XLR
- Control using 9 DMX channels
- Stand-alone operation
- Mounting clamp adapter
- Safety cable attachment point
- Magnetic ballast
- 4-digit LED display for user settings
- Power input: 120vAC-50/60Hz
- Current draw: 2.5 amps
- Size: 12"x12"x19.5"
- Weight: 11.8Kgs/26Lbs



COBRA 150

Specifications are subject to change without notice

# TECHNI-LUX FIXTURE RANGE

## TRACKER



### 250 WASH

IL-TRACKER250W/1

**Specifications:**

Lamp: CSD250/2 or MSD250/2 ■ Lamp life: 3000 hours ■ Color temperature: 8500°K ■ Luminous output: 18,000 Lux ■ Remote lamp on and off ■ Movement resolution: 16 bit ■ Pan: 530 ■ Tilt: 280 ■ Pan/Tilt motor speed ■ Consistent & auto correcting Pan/Tilt ■ Remote reset ■ Color wheel with 6 dichroic colors + open ■ CMY color mixing ■ CMY variable motor speed ■ 30 CMY macros ■ Beam shaper ■ Frost effect ■ Manual zoom: 8 to 22 ■ Variable shutter for strobe & quick blackouts ■ Motorized dimmer from 0 to 100% ■ DMX512 control ■ 3-pin In/Out XLR connection ■ 16 DMX channels ■ Digital display for addressing & fixture settings ■ 140mm fresnel lens ■ Ventilation via forced air ■ Anti-reflective coated glass optics ■ High efficiency parabolic glass reflector ■ Power: 120V-50/60Hz ■ Current draw: 4 amps ■ Size: 21"x17"x 17" ■ Weight: 58 lbs ■ Color: black



### 250 SPOT

IL-TRACKER250S/1

**Specifications:**

Lamp: CSD250/2 or MSD250/2 ■ Lamp life: 3000 hours ■ Color temperature: 8500°K ■ Luminous output: 18,000 Lux ■ Remote lamp on and off ■ Movement resolution: 16 bit ■ Pan: 530 ■ Tilt: 280 ■ Pan/Tilt motor speed ■ Consistent & auto correcting Pan/Tilt ■ Remote reset ■ Color wheel with 7 colors + open and continuous rotation ■ Static effect/gobo wheel with 3 gobos & 3 additional dichroic colors + open ■ 3-facet rotating prism with variable speed in both directions ■ Gobo wheel with 5 rotating, indexable & interchangeable gobos + open and continuous rotation ■ Remote selection of zoom degrees: 15, 18, 21, 24, & 26 ■ Frost effect ■ UV blacklight effect ■ Motorized focus ■ Variable shutter for strobe & quick blackouts ■ Motorized dimmer from 0 to 100% ■ DMX512 control ■ 3-pin In/Out XLR connection ■ 16 DMX channels ■ Digital display for addressing & fixture settings ■ Ventilation via forced air ■ Anti-reflective coated glass optics ■ High efficiency parabolic glass reflector ■ Power: 120V-50/60 Hz ■ Current draw: 4 amps ■ Size: 21"x 17"x 17" ■ Weight: 61 lbs ■ Color: black



### 575 WASH

IL-TRACKER575W/1

**Specifications:**

Lamp: CSR575/2SE or MSR575/2 ■ Lamp life: 1000 hours ■ Color temperature: 7200°K ■ Luminous output: 49,000 Lux ■ Remote lamp on and off ■ Movement resolution: 16 bit ■ Pan: 530 ■ Tilt: 280 ■ Pan/Tilt motor speed ■ Consistent & auto correcting Pan/Tilt ■ Color wheel with 7 dichroic colors + open ■ CMY color mixing ■ CMY variable motor speed ■ 18 CMY macros ■ Remote reset ■ Motorized beam shape rotation ■ Frost effect ■ Motorized zoom from 7 to 28 ■ Variable shutter for strobe & quick blackouts ■ Motorized dimmer from 0 to 100% ■ DMX512 control ■ 3-pin In/Out XLR connection ■ 16 DMX channels ■ Digital display for addressing & fixture settings ■ 200mm fresnel lens ■ Ventilation via forced air ■ Anti-reflective coated glass optics ■ Dual heat glass filters ■ High efficiency glass reflector ■ Power: 120V-50/60Hz ■ Current draw: 6 amps ■ Size: 27"x 18"x 18" ■ Weight: 88 lbs ■ Color: black



### 575 SPOT

IL-TRACKER575S/1

**Specifications:**

Lamp: CSR575/2SE or MSR575/2 ■ Lamp life: 1000 hours ■ Color temperature: 7200°K ■ Luminous output: 49,000 Lux ■ Remote lamp on and off ■ Movement resolution: 16 bit ■ Pan: 530 ■ Tilt: 280 ■ Pan/Tilt motor speed ■ Consistent & auto correcting Pan/Tilt ■ Remote reset ■ Color wheel with 9 dichroic colors + open and continuous rotation ■ Additional color wheel with 9 dichroic colors + open ■ UV blacklight effect ■ 3-facet rotating prism with variable speed in both directions ■ Static effect/gobo wheel with 9 gobos + open ■ Gobo wheel with 6 rotating, indexable, interchangeable gobos + open and continuous rotation ■ Remote selection of zoom degrees: 15, 18, & 22 ■ Motorized focus ■ Motorized iris ■ Variable shutter for strobe & quick blackouts ■ Motorized dimmer from 0 to 100% ■ DMX512 control ■ 3-pin In/Out XLR connection ■ 17 DMX channels ■ Digital display for addressing & fixture settings ■ Ventilation via forced air ■ Anti-reflective coated glass optics ■ High efficient parabolic glass reflector ■ Power: 120V-50/60Hz ■ Current draw: 6 amps ■ Size: 27"x 18"x 18" ■ Weight: 91 lbs ■ Color: black



Specifications are subject to change without notice.





## MOJOSCAN II

*IL-MOJOSCAN2*

The Mojo Scan 2 is our most compact X/Y mirror scanning fixture. It features a great selection of 13 gobo patterns and 15 colors at an affordable price point. The high output is attributed to the long lasting 150w metal halide lamp. Mojo Scan 2 can operate in stand alone audio mode as master/slave or via DMX using 4 channels of control. Its gobo and color wheels are separate, allowing the possibility of many combination effects. All mechanical functions use high quality stepper motors. Focusable using manual turn Lens.

**Specifications:** HTI 152w (included) or HTI 150w Lamp ■ Color wheel: 9 dichroic colors plus 6 color splits ■ Gobo wheel: 13 patterns ■ 1-4 fps shutter strobe effect using gobo wheel ■ Standalone Audio Master/Slave operation ■ DMX control via 4 channels ■ 3-Pin XLR input for DMX ■ Color: Black ■ Size: 18.7"x8.7"x6.3" ■ Weight: 8.6Kgs/19Lbs ■ Power: 120v-50/60Hz ■ Current Draw: 2.5 Amps



## SHIVA SCANS

The Shiva is an excellent X/Y programmable mirror scanner that projects a brilliant beam of light through its large optical path. All its functions are controlled via DMX512. Separate color and gobo wheels. These fixtures are stylish and value engineered for reliable performance.

### Features & Specifications:

#### Halogen 250w Versions

### SHIVA *IL-SHIVA*

X/Y Mirror: pan 170 deg & tilt 90 deg ■ Die-cast aluminum case ■ 9 colors plus white ■ 9 interchangeable gobos ■ Manual adjustable focus lens ■ Coated lenses: AR & IR ■ Beam Spread: 14.25 degrees ■ Strobe effect, 1-5 fps ■ 4 stepper motors ■ DMX input via 3-Pin XLR ■ DMX control on 4 channels ■ Dip Switch for address & function settings ■ Fan cooling ■ Mounting bracket ■ 37 foot candles at 33 feet ■ Lamp: EVC 250w 24v ■ Power: 120v-50/60hz, 3.5 amp current draw ■ Size: 26.3"x11.8"x7.1" ■ Weight: 15Kgs/33.1Lbs



### SHIVA R w/ROTATING GOBOS *IL-SHIVAR*

X/Y Mirror: pan 170 deg & tilt 90 deg ■ Die-cast aluminum case ■ 9 colors plus white ■ 6 interchangeable and variable speed, bi-directional rotating gobos ■ Manual adjustable focus lens ■ Coated lenses: AR & IR ■ Beam Spread: 14.25 degrees ■ Mechanical dimming and strobe effect from 1-7 fps ■ 6 stepper motors ■ DMX input via 3-Pin XLR ■ DMX control on 6 channels ■ Dip Switch for address & function settings ■ Fan cooling ■ Mounting bracket ■ 37 foot candles at 33 feet ■ Lamp: EVC 250w 24v ■ Power: 120v-50/60hz, 4.5 amp current draw ■ Size: 26.3"x11.8"x7.1" ■ Weight: 15Kgs/33.1Lbs

#### Metal Halide 200w Version

### SHIVA R 200 w/ROTATING GOBOS *IL-SHIVA200R*

X/Y Mirror: pan 170 deg & tilt 90 deg ■ Die-cast aluminum case ■ 9 colors plus white ■ 6 interchangeable and variable speed, bi-directional rotating gobos ■ Manual adjustable focus lens ■ Coated lenses: AR & IR ■ Beam Spread: 14.25 degrees ■ Mechanical dimming and strobe effect from 1-7 fps ■ 6 stepper motors ■ DMX input via 3-Pin XLR ■ DMX control on 6 channels ■ Dip Switch for address & function settings ■ Fan cooling ■ Mounting bracket ■ 40 foot candles at 33 feet ■ Lamp: MSD 200 long lasting metal halide ■ Power: 120v-50/60hz, 5 amp current draw ■ Size: 26.3"x11.8"x7.1" ■ Weight: 15.9Kgs/35Lbs

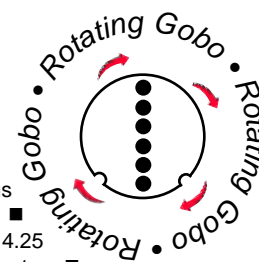



## GALILEO

The Galileo series of intelligent fixtures are high-power scanners with professional performance. Some of the distinguishing features are: high-speed colour and gobo changes, low-noise iris, high-speed gobo and prism rotation, precision linear dimmer, high strobe rate, 16-bit scanning resolution and the possibility of running color changer, gobo changer and strobe in sync with the music. The electronic system is modular and each function has its own independent control card, this facilitates maintenance and cuts running costs. Galileo scanners can be used for a wide variety of applications: from installation in professional sectors such as theatres and television studios to more widespread applications such as bands, entertainment venues, clubs and permanent installations.

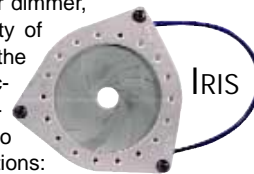

**Specifications for both fixtures:** Lamp: HM1200/GS ■ Lamp life: 750 hours ■ 2-tone beams ■ Color change with blackout ■ Analog color change ■ Color change with music sync ■ Variable speed rainbow effect ■ 3,200 °K CTO color conversion filter ■ Wash frost filter ■ Blacklight-UV filter ■ Layerable gobos: 25 combinations ■ Gobo change with blackout ■ Gobo change with music sync ■ 3-speed continuous gobo wheel rotation ■ Shutter /Strobe 0.5-12 fps ■ 0-100% linear dimmer ■ Iris ■ Pan/Tilt: 180°(0.4 sec.)/ 90°(0.2 sec.) ■ 8/16 bit resolution ■ DMX 512 & RS 232 input signal ■ Power supply 220/240V 50/60Hz (100/120V on request) ■ Thermal cut-off ■ Built-in microcomputer.



GOGO WHEELS



GALILEO IV  
COLOR WHEELS

**IL-GALILEO4:** Colors: 75 ■ 6,500 °K CTB color conversion filter ■ Soft edge frost filter ■ 4-color filter ■ Concentric 2-colour filter ■ Rotating gobos: 8 ■ 9 -facet fixed prism ■ 4 -facet rotating prism ■ Rotating eccentric prism ■ Electronic focus ■ Channels: 16 (18 in 16 bit mode) ■ Dimensions: 8.3"x45.1"x11.4" ■ Weight: 44 Kgs/97 Lbs  
**IL-GALILEO2:** Colors: 16 ■ 4 fixed gobos ■ 4 Rotating gobos ■ 4-facet fixed prism ■ Manual focus ■ Channels: 10 (12 in 16 bit mode) ■ Dimensions: 8.3"x45.1"x11.4" ■ Weight: 39.5Kgs/87Lbs



## VICTORY II 250 IL-VICTORY250

The Victory II is a fixture offering avant-garde performance, powerful light output and innovative technical features, including 16-bit mirror movement control and automatic freestanding operation without any need for a controller. SGML lengthy experience in the lighting control field has enabled the development of a product which is highly reliable and precise and whose mechanics, optics and electronics have been entirely designed by SGM. Thanks to the compact lines, Victory II scanners are suitable for an endless variety of applications, from fixed installations to mobile set-ups, and have been designed to function almost any position.

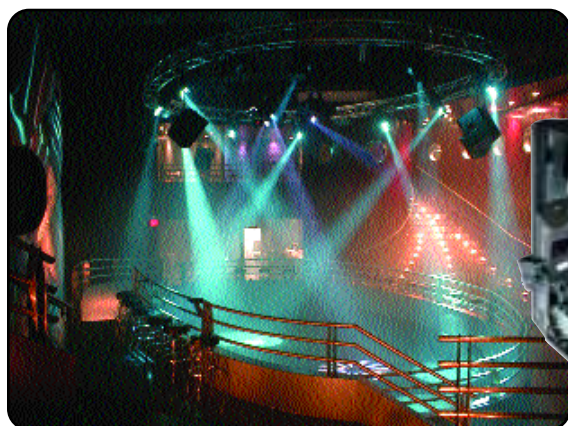

**Specifications:** Lamp EVC 24V 250W halogen ■ Lamp life: 300 hours ■ 16 Colors ■ Two-tone beams ■ Color change with blackout ■ Analog color change ■ Color change with music sync ■ Rainbow effect with adjustable speed ■ CTB color conversion filter ■ Frost filter ■ 4 Fixed gobos ■ Rotating gobos ■ Gobo change with blackout ■ Analog gobo change ■ Gobo change with music sync ■ Continuous gobo rotation ■ 4-facet rotating prism ■ Shutter ■ Strobe 1-9 flashes per second ■ Manual focus ■ Pan/Tilt: 180°(0.5 s)/90°(0.3 s) ■ 8/16 bit resolution ■ Stand-alone functions ■ 10 Channels (12 in 16 bit) ■ DMX 512 -RS 232 input signals ■ Automatic power cut-off in the event of overheating ■ Power supply: 110v or 220v AC 50/60Hz ■ Dimensions: 7.1"x25.6"x13.8" ■ Weight: 14Kgs/30.9Lbs



Specifications are subject to change without notice.



## TRACER 2 1200

FS-TRACER2M



The Tracer2 1200 is the revolutionary followspot with full electronic control. All functions are at the operator's fingertips. Effects can be controlled by the console, powered directly from the projector or by remote DMX 512. DMX 512 control allows shows to consistently synchronize cues using multiple followspots. The main features of Tracer (power, versatility and overall compact size) have been carefully optimized to maximize performance. The unique main "Tracer" function allows for precise beam positioning with accuracy and confidence.

**Specifications:** Selectable beam angle for different throw distances: 10.5°, 12°, 14° to 16° ■ 1200w metal halide 5600°K lamp ■ 7 dichroic colors plus open producing 24 color combinations ■ Color wheel rainbow rotation effect ■ Bi-color splits ■ Color temperature correction filters: 3200°K and 6000°K ■ Linear motorized mechanical dimming from 0-100% ■ Variable speed strobing and black-out shutter ■ Motorized focus ■ Tracer function ■ Gobo wheel with 4 M-Size patterns ■ Typical throw distance: 16 to 175 feet ■ Motorized iris aperture ■ 3-pin and 5-pin XLR in/out data connectors ■ External main electrical fuse ■ DMX 512 using 5 channels ■ Dip-switch DMX addressing ■ LED status indicator ■ Carrying handles ■ Forced air ventilation ■ Lamp: MSR1200 or HSR1200 ■ Lamp life: average 800 hours ■ Power factor correction ■ Internal ballast ■ Power: 208-230v at 50/60Hz ■ Current draw: 7.3 Amps ■ Size: 35"x17"x10" ■ Weight: 40Kgs/89Lbs

### VERSATILE

Total control of an extensive array of functions for use in small and large venues.

### COMPACT

Small body design encompasses the latest in optical projection, mechanical and electronic technologies.

### POWERFUL

Quality engineered optics coupled with high output metal halide lamp, produce extraordinary light output.

Tripod stands sold separately. See page 37.



## NEWTON

FS-NEWTON



The Newton 1200 intelligent follow spot is based on the sophisticated, reliable and well-proven technology of SGM Galileo fixtures. It is designed for professional medium-to-long throw use in theater, television studios and concerts applications, although its user friendliness makes it suitable for any use. This follow spot can be used where automatic or multiple synchronized follow spots need to be on set cues. Using DMX, a lighting designer can produce a controlled cue list and have multiple follow spots responding to a centralized console. Manual control is offered using a separate Newton controller. It mounts next to the follow spot where adjustment vibrations do not affect the light beam while in operation. It is constructed of rugged die-cast and extruded aluminum, however it remains as manageable as possible, with two handles on the sides and a grip on the rear panel. On the rear panel there is also a built-in settings panel with a display. Operators can get information on the follow spot's status, DMX addressing, and fixture and lamp operating times.

**Specifications:** HMI 1200/GS discharge lamp ■ Lamp life: 750 hours ■ 7 easily replaced standard colors ■ Two-tone beams ■ Adjustable speed rainbow effect ■ Automatic color change with adjustable crossover time ■ High-speed color changer (0.06 sec.) ■ Strobe 0.5 -12 flashes per second ■ Iris ■ Manual focus control ■ 0-100% dimmer ■ DMX512 or RS-232 input signal ■ Built-in microcomputer with display for setting fixture functions and checking status for important information ■ Power supply requirements: 220/240V 50/60Hz ■ Controllable via dedicated Newton Control unit or other control desk with DMX 512 or RS-232 ■ Newton Control's special mounting system is built with telescopic stainless steel tubes with adjustment and multi-direction rotation through 360° ■ Dimensions: Newton 1200: 8.3"x 45.1"x 11.4" Newton Control: 2.6"x15.8"x11.2" ■ Weight: Newton 1200: 23 Kg/50.7Lbs. Newton Control: 4 Kgs/8.8 Lbs

**TR-NEWTONSTAND** A professional 2-section telescopic stand in die-cast aluminum and stainless steel tubing that is in compliance with European safety norms can be purchased separately.  
**FS-NEWTONLENS** Long Throw Lens

## ARENA SERIES



Tripod sold separately. See page 37.

### FOLLOWSPOT MSR1200

**FS-ARENA1200M**

- Lamp: MSR1200/2 - 110,000 lux
- Lamp life: average 800 hours
- Typical Throw: 30 - 150 feet
- High quality dual lens system
- Efficient 68mm glass reflector
- Zoom adjustment: 10 - 18 degrees
- Adjustable focus
- 4 Shaping blades included
- Mechanical shutter/dimmer
- Blackout iris included
- Color frame 7.25"x7.25" included
- Rear handle & side bar grip area
- Quiet 49dB operation
- Extruded aluminum & steel plate body
- External ballast power supply
- Output selector: 575w or 1200w
- Rating: IP20
- Power input: 117vAC-50/60Hz
- Current draw: 10 amps
- Fixture size: 40.6"x13.15"x10.79"
- Ballast size: 20.6"x9.1"x9.4"
- Fixture weight: 17Kgs/37.5Lbs
- Ballast weight: 25Kgs/55.12Lbs
- Color: black powder coat paint
- Options: **GOBO-HOLDF SAR-B** Gobo Holder - B size
- **FS-ARENACC** - 5 Color Changer for gel



### FOLLOWSPOT MSR575

**FS-ARENA575M**

- Lamp: MSR575/2 - 49,000 lux
- Lamp life: average 1000 hours
- Typical Throw: 30 - 100 feet
- High quality dual lens system
- Efficient 68mm glass reflector
- Zoom adjustment: 10 - 18 degrees
- Adjustable focus
- 4 Shaping blades included
- Mechanical shutter/dimmer
- Blackout iris included
- Color frame 7.25"x7.25" included
- Rear handle & side bar grip area
- Quiet 49dB operation
- Extruded aluminum & steel plate body
- External ballast power supply
- Rating: IP20
- Power input: 117vAC-50/60Hz
- Current draw: 6 amps
- Fixture size: 40.6"x13.15"x10.79"
- Ballast size: 20.6"x9.1"x9.4"
- Fixture weight: 17Kgs/37.5Lbs
- Ballast weight: 22Kgs/48.4Lbs
- Color: black powder coat paint
- Options: **GOBO-HOLDF SAR-B** Gobo Holder - B size
- **FS-ARENACC** - 5 Color Changer for gel



### FOLLOWSPOT MSD250

**FS-ARENA250M**

- Lamp: MSD250/2 - 18,000 lux
- Lamp life: average 2000 hours
- Typical Throw: 10 - 50 feet
- High quality dual lens system
- Efficient 55mm glass reflector
- Zoom adjustment: 10 - 28 degrees
- Adjustable focus
- 4 Shaping blades included
- Color frame 5.9"x5.9" included
- Blackout iris included
- Dual handles for easy operation
- Extruded aluminum and steel plate body
- Internal ballast
- Rating: IP20
- Power input: 117vAC-50/60Hz
- Current draw: 4 amps
- Size: 28.62"x14.8"x8.7"
- Weight: 16Kgs/35.2Lbs
- Color: black powder coat paint
- Options: **GOBO-HOLDF SAR2-M** Gobo Holder - M size
- **FS-ARENA250CC** - 5 Color Changer for gel



### FOLLOWSPOT 1200

**FS-ARENA1200T**

- Lamp: 71-2529 CP90 1200w 120v - GX9.5 30,800 lux
- Lamp life: average 150 hours
- Typical Throw: 25 - 85 feet
- High quality dual lens system
- Efficient 68mm glass reflector
- Zoom adjustment: 10 - 18 degrees
- Adjustable focus
- 4 Shaping blades included
- Mechanical shutter/dimmer
- Blackout iris included
- Color frame 7.25"x7.25" included
- Rear handle & side bar grip area
- Quiet 49dB operation
- Extruded aluminum & steel plate body
- Rating: IP20
- Power input: 117vAC-50/60Hz
- Current draw: 11 amps
- Fixture size: 40.6"x13.15"x10.79"
- Fixture weight: 20.5Kgs/45.1Lbs
- Color: black powder coat paint
- Options: **GOBO-HOLDF SAR-B** Gobo Holder - B size
- **FS-ARENACC** - 5 Color Changer for gel

Specifications are subject to change without notice.



### COLOR CHANGER

**FS-ARENACC**

- Option for ARENA1200M, ARENA575M, and ARENA1200T Follow Spots

## FOLLOWSPOT MOONLIGHT SERIES

### FOLLOWSPOT Moon 1200w

**FS-MOON1200/1**



#### Specifications:

- Power: 120V 50 / 60Hz
- Power consumption: 1300 VA in built factor correction
- Lamp: HTI1200/D7/60
- Lamp socket: SFC 10-4 (115mm)
- Colors: white + 6 colors from 3 dichroic filters with high chromatic yield
- Removable iris
- Zoom 2.5° - 13°
- External Ballast Power Supply
- Black-out
- Size: 34.3"Lx14.2"Wx17.7H
- Weight: 15.5 Kg/34.2 Lbs
- Color: black



### FOLLOWSPOT Moon 1000w

**FS-MOON1000/1**

- Specifications: Power: 120v 50 / 60Hz
- Power consumption: 1000w
- Lamp: Halogen T11 1000w 120v
- Lamp socket: GX 9.5 ceramic
- Removable iris
- Working position: ± 45°
- Zoom: 2.5° - 13°
- Black-out
- Size: 30.3"Lx14.2"Wx17.3H
- Weight: 12.2 Kg/26.8 Lbs
- Color: black
- Includes Color Changer



### FOLLOWSPOT Moon 575w

**FS-MOON575/1**

- Specifications: Power: 120V 50 / 60Hz
- Power consumption: 600 VA with built-in factor correction
- Lamp: HMI575W/GS (750 hours)
- Lamp socket: SFC 10-4 (115mm)
- Colors: white + 6 colors from 3 dichroic filters with high chromatic yield
- Removable iris
- Zoom: 2.5° - 13°
- Black-out
- Size: 34.3"Lx14.2"Wx17.1H
- Weight: 22 Kg/48.5 Lbs
- Color: black



### COLOR CHANGER FS-MOONCC

- Option for MOON1200 or MOON575 Follow Spots



## COLORRGB FLOOD WASH

### IL-COLORRGB

The ColorRGB incorporates RGB color mixing into a single fixture with wide dispersion. It has the ability to create virtually any color combination. Using a DMX controller, both color and intensity may be altered. Great for washing wide areas with color, for backgrounds and stage highlights.

**Specifications:** Built in 3 channel dimming system, no additional dimmers needed ■ Red, Green, and Blue dichroic filters ■ Digital display addressing ■ X 40 by Y 60 degree beam spread ■ 2 or 3 channel DMX input operation via XLR ■ 0-100% dimming ■ Lamp sources include 3 x EHM 300w or 3 x FCL 500w ■ Black powder coat paint finish ■ Power: 120v-50/60Hz ■ Current Draw: 13 Amps ■ Size: 15.6"x10"x6.7" ■ Weight: 6.8 Kgs/15 Lbs

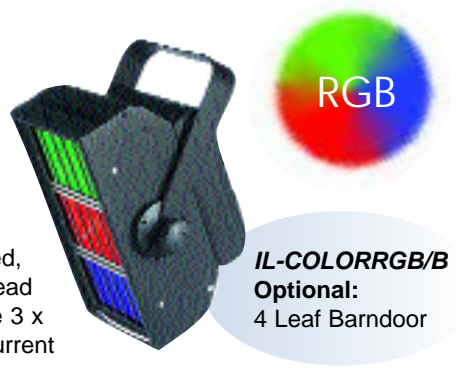

**IL-COLORRGB/B**  
Optional:  
4 Leaf Barndoor

## COLOR DYNAMIC

### EL-COLORDYN100

Color Dynamic 100 is a fixture based on fiber optic technology, able to generate a series of constantly changing light beams, creating extremely effective eye-catching images very similar to the fractals generated by computers, with constantly changing colors and shapes. Color Dynamic 100 is a user-friendly fixture with only two controls to adjust color wheel rotation speed and effect speed. It can be easily installed in any venue, thanks to its compact dimensions and light weight body. Color Dynamic 100 is fitted with a 100W halogen lamp with an average lamp life of 1,500 hours, which ensuring great luminous power and low running costs.

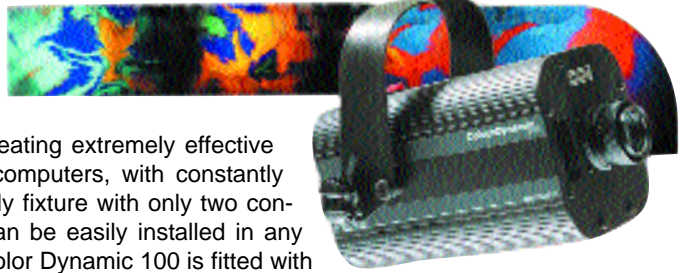

**Specifications:** Lamp: 64637 EFP/LL 100w 12v ■ Power: 120v 50/60hz ■ Current draw: 1.5 Amps ■ Size: 14.2"x7.08"x7.09" ■ Weight: 5.5Kgs/12.1Lbs

## COLOR BLASTER 250

### IL-COLOR1

The Color Blaster 250 delivers a wide, hard edged beam of rich dichroic color. Features include ten dichroic colors plus white, strobe and 0 - 100% dimming. Run it in automatic music mode to enjoy a pre-programmed show or DMX control from any DMX-512 controller. Select either mode with the flip of a dip switch. Self test function and DMX signal termination. With the Color Blaster you get an easy to use color changer that can serve many lighting applications.

**Specifications:** ELC 250w 24v lamp ■ Power: 120v 50/60Hz ■ Power Consumption: 300W ■ 10 dichroic colors + white ■ Rainbow effect; shutter and dimming ■ 1-5 fps Strobe ■ 2 DMX Channels: 1-color/shutter, 2-dimmer ■ Large optical path ■ Audio Control ■ 3-pin XLR Connectors ■ Standard DMX512 control and address ■ Electronic dimming 0-100% ■ Size: 11"x5.9"x6.1" ■ Weight: 6.3 kg/14Lbs



**PA-PIN46BLK** Par46 pin-spot with 3 prong grounded plug. Black color finish and screw on front cap. Produces very narrow shaft of light. Includes 4535 6v/30w lamp. Weight: 1.4Kgs/3Lbs



**PA-PIN36BLK** Quality pin-spot Par36 with screw on front cap and Edison (3 prong) grounded power cord. Comes with 30w 6v 4515 lamp. Black finish. Color lens optional. Weight: 1.1Kgs/ 2.5Lbs

**PA-PIN36BLKUL** U.L. approved version.



### PA-PIN36P

Quality polished aluminum pin-spot for par 36 lamp with ring front clip and grounded power cord. Comes with 30w 6v 4515 lamp. Polished finish. Color lens optional. Weight: .91Kgs/2.0Lbs



### PA-PIN36BLK/C

Pin-Spot 36 with a rotating 4-color 9" diameter wheel. Colors are red, yellow, green, and blue. Comes with 30w 6v 4515 lamp. Rotates at 1-2RPM. Size: 11.8"x9"x9.8" ■ Weight: 2.1Kgs/4.6Lbs



### PA-PIN36OSC1

Oscillating pin-spot effect. Sweeps side to side 180 degrees. Comes with 30w 6v 4515 lamp. Black finish. Color lens optional. Size: 6.4" x 6.4" x 11.4" ■ Weight: 1.4Kgs/3.1Lbs

### PA-LENS36X PA-LENS46X

Plastic lens covers for pin-spots Par36 and Par46. Available in Amber, Aqua, Blue, Green, Magenta, Purple, Pink, Red, Yellow. X specifies color when ordering.



# PAR-CANS



Manufactured from high quality spun aluminum and supplied with an octagonal gel frame holder and lamp socket. Our par-cans incorporate a unique clutch locking device which is designed to take the additional load of a color changer. The single handed action enables minute adjustment without the need for tools. Heavy duty yokes and steel reinforced rivets withstand touring and rental applications. All par-cans are available in either black or polished. Lamps or reflector kits sold separately.



**LONG AND SHORT PAR CANS** - High quality and heavy duty spun 2mm aluminum, with 4th clip, gel frame, GX16d socket, cable gland, protection screen, clutch brake, lamp retention ring, and 3ft power cable with Edison plug. **X** specifies Polish, Black or White finish in order code. Lamps sold separately.

- PA-PAR64LX** **LONG PAR CAN**  
Available in Polish, Black or White - U.L. approved.
- PA-PAR64SX** **SHORT PAR CAN** - Polish or Black  
Body similar to long par can - *Not U.L. approved.*
- PA-PAR56LX** Available in **long**: Polish, Black or White.  
*Black and polish are U.L. listed*
- PA-PAR46LX** Available in **long**: Polish or Black
- PA-PAR20XX** Available in **long**: Polish, Black or White  
Available in **short**: Polish  
Both available with E26 medium screw in socket.



**PA-PAR38X** High quality spun aluminum. Includes: 4th clip, gel frame, E26 medium screw in base, cable gland, and power cable with Edison plug. Can be used with a variety of screw base par or reflector lamps. **X** specifies Polish or Black finish in order code. U.L. approved.

## FLEXIPAR PA-FLEXIPAR/B

The FlexiPar is an attractive aluminum die-cast PAR lighting fixture with selectable beam angle lenses and adjustable yoke. Its special reflector produces an output which exceeds traditional par-cans using higher wattage lamps. Reduces power consumption and dimmer distribution. Four interchangeable glass lenses are included to easily vary the light beam width from Wide, Medium, Narrow to a Very Narrow. Includes one 7.5"x7.5" gel frame and power cord. Power plug sold separately.  
**Specifications:** Lamp: FLK 575 ■ Power: dependent on lamp, 120v-230v 50/60Hz ■ Current draw: FLK 575 at 4.8 Amps ■ Size: 11.5"x10"x8.5" ■ Weight: 3.4Kgs/ 7.48Lbs



FlexiPar Spare lenses: glass 7" diameter

## FLEXITool

### PA-FLEXIPARTOOL

Great tool for quick and easy removal of flexipar lenses.



**PA-FLEXIPARLM**  
Medium Flood, 12x19°



**PA-FLEXIPARLN**  
Narrow Beam, 10°



**PA-FLEXIPARLVN**  
Very Narrow Beam, 8°



**PA-FLEXIPARLW**  
Wide Flood, 16 x 33°

## PAR-CAN ACCESSORIES & PARTS

- PA-BARNDOOR20B** 4 leaf barn doors for Par 20 Black
- PA-BARNDOOR56B** 4 leaf barn doors for Par 56 Black
- PA-BARNDOOR64X** 4 leaf barn doors for Par 64, **X**= Polished or Black
- PA-PAR4THCLIPP** 4th spring loaded clip for Par 46, 56, 64 polished
- PA-FRAME##X** Octagonal gel frames for Par **16, 20, 38, 46, 56, 64**, Polished or Black
- PA-PAR##RING** Lamp retaining ring for Par **46, 56, 64**
- PA-PARBLOCK** 4 screw ceramic terminal block
- PA-PARCAPKNOB** Par can cap knob & spring fastener
- PA-PARKNOB** Side knob for Par 46, 56, 64
- PA-PARSTRAIN** Par can strain relief-black
- PA-POWERCORD1** Power Cord 14AWG/6ft w/plug
- PA-POWERCORD2** Power Cord 18AWG/6ft w/plug
- PA-POWERCORD3** High Temp Par Power Cable 2ft
- PA-RF##M** Medium flood reflector kit for Par **56, 64**
- PA-RF##N** Narrow flood reflector kit for Par **56, 64**
- PA-RF64W** Wide flood reflector kit for Par 64
- ZELS0037** Socket for Par 46, Medium Side Prong
- ZELS0038** Socket for Par 64, GX16d



**X** denotes various specifications needed for correct part selection.

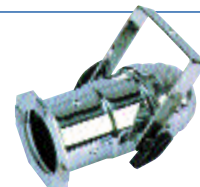

### PA-PAR16E17X

Par 16 Can with E17 lamp socket, gel frame and power cord.  
**X** specifies color in Polish or Black finish.

**75 WATT MAXIMUM USAGE**

## PARBARS

Par bars are designed for concert, stage and touring applications where quick par can set-ups and tear-downs are essential. Available in several electrical configurations. May be used with Par 64, Par 56 and Par 46 Cans. Polished aluminum 2" pipe with silicon cable wiring.



### PD-PARBAR4/1P

For use with four par cans wired in series, using ACL 28v type lamps ■ Power input: silicon cable ■ Length: 5 feet ■ Weight: 3Kgs/6.6Lbs

**GREAT FOR ACLs!**



**PD-PARBAR4/4P** For use with four par cans wired to 4 individual circuits ■ Power input: 19 pin connector ■ Length: 5 feet ■ Weight: 3Kgs/6.6Lbs

**PD-PARBAR6/6P** For use with six par cans wired to 6 individual circuits ■ Power input: 19 pin connector ■ Length: 7.5 feet ■ Weight: 5Kgs/11Lbs



# FL-SERIES FLUORESCENT COOL LIGHTS

Dexel offers a full line of fluorescent fixtures suitable for both studio and location lighting. Fluorescent fixtures produce more lumens per watt than conventional tungsten incandescent fixtures resulting in less heat emission, less power consumption and savings on cooling costs. All Dexel Fluorescent fixtures come with louver and intensifier accessories at no extra cost. Specify Color temperature of 3200 degrees Kelvin to match conventional incandescent fixtures or 5600 degrees Kelvin to match natural or artificial daylight fixtures.

DMX technology makes it possible to integrate the Dexel Fluorescent units into a digitally controlled lighting system. Using DMX control, multiple units can be wired into a network with low voltage wiring and controlled from a digital console. A local/DMX selector allows operation by potentiometer or DMX control. All DMX fixtures have manual dimming controls local at the fixture without external DMX control. All units are 100% flicker-free with electronic ballasts.

*Photo metrics and additional specifications are available upon request.  
All fluorescent fixtures below do not include lamps, power plugs or clamps. Items sold separately.*

Luz Fria Studio (Studio Cool Lights) are ideal for studio use and come complete with intensifier. The Studio version is also available with the pole operation feature. Use for high quality soft light or combine with quartz-halogen fresnels for an entire studio set-up. Typical applications include fill light, soft-key, back light, Chromakey and Ultramatte cyc lighting and virtual studios.

The following fluorescent softlights include the reflective intensifiers.

CODE	DESCRIPTION	LAMP TYPES
<b>FL-LFS2/55</b>	Softlight 2x55w with DMX/Local dimming 120v-230v Size: 29.55"x10.63"x12.80" ■ Weight: 10.5Kgs/23.15Lbs	F55BXCIN3200 or 5600
<b>FL-LFS4/55</b>	Softlight 4x55w with DMX/Local dimming 120v-230v Size: 30.33"x12.41"x17.33" ■ Weight: 15.5Kgs/34.17Lbs	F55BXCIN3200 or 5600
<b>FL-LFS4/55P</b>	Softlight 4x55w Panoramic with DMX/Local dimming 120v-230v Size: 53.97"x10.63"x14.26" ■ Weight: 21Kgs/46.3Lbs	F55BXCIN3200 or 5600
<b>FL-LFS6/55</b>	Softlight 6x55w with DMX/Local dimming 120v-230v Size: 31.12"x16.94"x22.85" ■ Weight: 18Kgs/39.7Lbs	F55BXCIN3200 or 5600

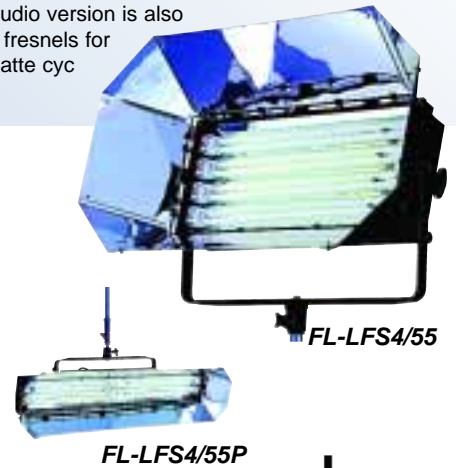

Specifications are subject to change without notice.



**FL-DFL2/55**

Power Flo is the ideal lightweight solution for video and film location lighting. High output and low current draw works well on locations with limited power options. Available with standard household "Edison" style plug, these units work well where circuit over-loading is a problem. Equipped with lamps with a CRI of 95, colors respond to the special sensitivity curves of modern film stocks and high-definition electronic media.

CODE	DESCRIPTION	LAMP TYPES
<b>FL-DFL2/20</b>	PowerFlo 2x20w with DMX/Local dimming 120v-230v Size: 28.37"x12.61"x13.00" ■ Weight: 5Kgs/11.02Lbs	F20T12CIN3200 or 5500
<b>FL-DFL2/40</b>	PowerFlo 2x40w with DMX/Local dimming 120v-230v Size: 52"x12.61"x13.00" ■ Weight: 10Kgs/22.05Lbs	F40T12CIN3200 or 5500
<b>FL-DFL2/55</b>	PowerFlo 2x55w with DMX/Local dimming 120v-230v Size: 26"x12.09"x12.84" ■ Weight: 4.5Kgs/9.92Lbs	F55BXCIN3200 or 5600
<b>FL-DFL4/20</b>	PowerFlo 4x20w with DMX/Local dimming 120v-230v Size: 28.37"x14.97"x14.97" ■ Weight: 7Kgs/15.43Lbs	F20T12CIN3200 or 5500
<b>FL-DFL4/40</b>	PowerFlo 4x40w with DMX/Local dimming 120v-230v Size: 52"x14.97"x14.97" ■ Weight: 13Kgs/28.66Lbs	F40T12CIN3200 or 5500
<b>FL-DFL4/55</b>	PowerFlo 4x55w with DMX/Local dimming 120v-230v Size: 26"x14.02"x14.33" ■ Weight: 6.5Kgs/14.33Lbs	F55BXCIN32 or 5600

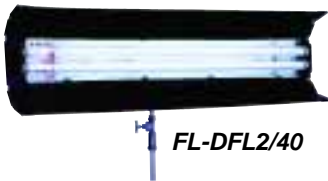

**FL-DFL2/40**



**FL-DFL4/40**

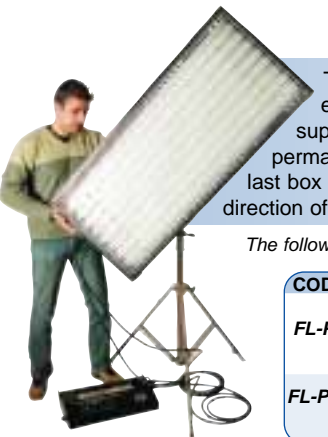

The Power Bank offers lightweight but rugged aluminum construction and can be mounted in either a horizontal or vertical orientation. It is supplied with a mounting plate and support for lighting stands, or it can be mounted directly on the wall or ceiling for a more permanent installation. The lamps of the Power Bank can be controlled remotely from a ballast box using the control panel. Silver focusing louver included to help control the spread and direction of light.

The following fluorescent banks supplied with mounting plate, louver, extension cable, ballast & control panel.

CODE	DESCRIPTION	LAMP TYPES
<b>FL-PB320</b>	Power Bank 8 Lamp 40w with DMX/Local dimming Size: 49.21"x11.8"x23.6" ■ Weight: 5Kgs/11.02Lbs	F40T12CIN3200 or 5500
<b>FL-PB400</b>	Power Bank 10 Lamp 40w with DMX/Local dimming Size: 49.21"x11.8"x27.5" ■ Weight: 6Kgs/13.23Lbs	F40T12CIN3200 or 5500



**FL-PRGB**

## FLUORESCENT POWER RGB

Full color mixing fluorescent fixture for cyclorama lighting, chromakey (blue or green), stages, and other architectural light effects. Intensity control of each lamp from 0-100%. Uses energy saving and long life (20,000 hours) fluorescent lamps.

### Specifications:

- Lamps 4x54w
- Red, Green, Blue, White
- 4 Channel DMX 512
- 5 pin XLR input
- Power: 120v-230v 50/60Hz
- Current draw: 2 Amps
- Size: 50"x6.7"x20.9"
- Weight: 13.5Kgs/ 29.8Lbs



## ELLIPSOIDALS W/ZOOM TH-5016 & TH-5017

Used for hard edge beam shaping and pattern/gobo projections. These ellipsoidals have variable beam angle zoom. All units come complete with mounting yoke, color frame, shaping blades and "B" size pattern holder. Built from weight extruded aluminum and die-cast parts. Uses new optical dichroic reflector technology which produces more light output and consumes less energy than conventional 1000w ellipsoidals. Lamp and power plug sold separately. Lamp base G9.5. For 120v: use 575 watt GLC or extended life GLA lamp type. For 230v: use 600 watt GKV or extended life GLB lamp type. Add **W** to code for white.

**TH-5016:** Zoom adjustable from 15 to 30 degrees ■ Weight: 6.8Kgs/15Lbs

**TH-5017:** Zoom adjustable from 25 to 50 degrees ■ Weight: 6.8Kgs/15Lbs

*Options, dimensions & photometric data are available upon request.*



## BANK LIGHTS

Par 36 bank lights, also known as punch lights, perform as audience blinders and as bang lights in stage shows. Protective metal grill over each lamp. Available in 4 or 8 lamp sets with mounting yoke. Internal wiring must be completed by user. Use with Par 36 DWE 650 watt lamps sold separately. Body finish in black powder coat paint.

**TH-BANK4:** Power: two power cords with Edison plugs ■ Size: 18"x20"x4.5" ■ Weight: 5.2Kgs/11.4Lbs

**TH-BANK8:** Power: four power cords with Edison plugs ■ Size: 18"x27"x4.5" ■ Weight: 9Kgs/19.8Lbs



## MINIBRUT TF-6002

MiniBrut TF-6002 is also available in several other

sizes. Most popular is 6 lamp unit shown. Can be used for stage blinding effect or T.V. & film studio general lighting. Uses DWE 650w lamps sold separately. Side leaf doors included. Weight: 8.62Kgs/19Lbs

*Uses different lamp types for 230v. Dimension & photometric data are available upon request.*



## MINILUZ 1000 TF-5303

MiniLuz 1000 includes barn doors. Maximum horizontal beam angle of 63 degrees. Lamps sold separately. Use FCM or FHM lamp for 1000 watt operation or FDN for 500 watt. Weight: 1.6Kgs/3.5Lbs

*Uses different lamp types for 230v. Dimensions & photometric data are available upon request.*

## FRESNELS

### TF-FRESNEL SERIES

The fresnel series ranges from 300 watt to 5000 watt fixtures. All units come complete with mounting yoke, color frame, barn-doors and adjustable beam spread. Lamp and power plug sold separately.

**TF-5001:** Lens 3" diameter ■ 300 watt ■ Lamp base GY9.5 for FKW lamp ■ Beam adjustable from 16 to 60 degrees ■ Weight: 2.5Kgs/5.5Lbs

**TF-5002:** Lens 4" diameter ■ 650 watt ■ Lamp base GY9.5 for FRK or FRG lamps ■ Beam adjustable from 16 to 60 degrees ■ Weight: 3.6Kgs/8Lbs

**TF-5003:** Lens 6" diameter ■ 1000 watt ■ Lamp base G22 for EGT or EGN lamps ■ Beam adjustable from 9 to 55 degrees ■ Weight: 7.7Kgs/17Lbs

**TF-5004:** Lens 10" diameter ■ 2000 watt ■ Lamp base G38 for CYX lamp ■ Beam adjustable from 9 to 45 degrees ■ Weight: 12.7Kgs/28Lbs

**TF-5005:** Lens 12" diameter ■ 5000 watt ■ Lamp base G38 for DPY lamp ■ Beam adjustable from 12 to 57 degrees ■ Weight: 19.5Kgs/43Lbs

*Lamp types listed are for 120v. Different lamp types required for 230v operation. Dimensions & photometric data are available upon request.*



## CYC SERIES

These cyclorama lights feature asymmetrical reflectors and can support a variety of wattages ranging from 100 to 1000 watts. Each unit compartment requires one power circuit each. All cyc lights include color frame and R7s lamp socket. Lamps sold separately.



Iris Cyc available in single unit or set of four. Use 168-189mm lamps

**TF-5321:** Single unit with yoke ■ Weight: 7.8Kgs/17.2Lbs ■ Size: 21"x16.5"x9.1"

**TF-5324:** Quad unit with yoke ■ Weight: 31Kgs/68Lbs ■ Size: 70"x16.5"x9.1"

Ground & Sky focusable versions come in single units which can be combined in groups to form banks. Use 118mm lamps

**TH-5380G:** Ground single unit ■ Weight: 5.9Kgs/13Lbs ■ Size: 11.8"x11.8"x8.7"

**TH-5380S:** Sky single unit with yoke ■ Weight: 6.4Kgs/14.1Lbs ■ Size: 15.75"x19"x8.7"

*Use different lamp types for 230v. Dimensions & photometric data are available upon request.*



## RIBALTA SERIES Stage Light Cyc Series

The Ribalta is the ideal choice when you need a bright, even wall or cyc wash. Ribaltas are available with either symmetrical or asymmetrical aluminum reflectors. The fixtures may be lamped from 250 to 750 watts using double ended linear halogen 119mm R7s bulbs. All units come complete with mounting yoke, and color frames. Lamps and power plugs sold separately.



Symmetrical reflector:

**TH-RIBALTAS1** Single head ■ Size: 11"x11.93"x5.67" ■ Weight: 2Kgs/4.41Lbs

**TH-RIBALTAS4** Four head ■ Size: 40.6"x11.93"x5.67" ■ Weight: 6.6Kgs/14.6Lbs

Asymmetrical reflector:

**TH-RIBALTAA1** Single head ■ Size: 11"x11.93"x5.67" ■ Weight: 2Kgs/4.41Lbs

**TH-RIBALTAA4** Four head ■ Size: 40.6"x11.93"x5.67" ■ Weight: 6.6Kgs/14.6Lbs

## STRIP LIGHTS

**TH-5340-10 lamp**

**TH-5341-20 lamp**

MR16 strip lights. Available in 10 lamp or 20 lamp set. Choice of either 50 or 75 watt lamps and various beam angles. Lamp options: EXZ, EXN, EYF, EYC. Lamps sold separately.







**SHOWCAD ARTIST**  
Object oriented lighting & show control  
**CT-SCADA**



**Artist** is a multi-role lighting and show controller and is the next generation system to ShowCAD, a controller that has become a standard for the nightclub industry. ShowCAD's flexibility has also enabled it to be installed in many AV, architectural, theatrical, theme park, T.V. and film applications. **Artist** now pushes the envelope for show design and control further still...

**Objectives** From Install to show in quickest possible time ■ Object oriented programming-scenes, fixtures and cues know their identity ■ Access to all operating system resident devices including DVD and video ■ No limit placed on number of DMX output channels ■ No limit on the number of scenes and cues running concurrently

**Additional** Wizards to guide through those first tentative steps ■ Graphical editor to create custom fixture specific templates ■ Instant access focus, color, gobo and beam palettes ■ Sub-scenes ■ Pile add ■ Blind edit ■ Snagging tools soothe the tedious hours of DMX troubleshooting ■ On screen help ■ Powerful LED Matrixing system ■ Full show control and system integration ■ Video to LED mapping and pixilation ■ Integrated SMPTE timecode ■ Real time clocks and timers ■ Plus much more!



*Check out the online product demo!*  
<http://www.showcad.com>

**Hardware** Recommended minimum: Windows 2000 or newer, Pentium III 400 MHz, 128Mb RAM, 40Gb HDD space, CD-ROM, sound card, 1024 x 768 x 16 bit color monitor ■ Interface requirements: various ISA, USB, PCI and network as required ■ The Artist Kit includes CD software and 512 DMX USB box ■ Additional boxes may be purchased for multiple sets of 512 channels ■ Size: 3"x3.5"x1.5" ■ Weight:.15Kg/.325Lbs

Specifications are subject to change without notice.



**MLC 128R CT-NSMLC128R**



Take creative command of your intelligent lighting presentation with the fully programmable, rack mount MLC 128R control system from Leviton. With the pre-established library of lighting fixtures, you can simply and quickly control up to 128 intelligent devices. Show design is a snap with the ingeniously organized front panel that addresses your need for programming flexibility. And the unit provides as many as 1,024 user-programmable scenes to handle any lighting challenge.

**Specifications:** Up to 128 individual devices ■ 512 DMX control channels ■ 128 Micro-Plex control channels ■ Up to 1,024 scenes ■ 256 patterns (series of scenes) ■ Stores 256 shows (series of linked patterns) containing up to 24 patterns ■ Simultaneous control of up to 64 devices ■ Two line, 40 character backlit LCD display ■ Fade times from .1 second to 59 minutes, 59.9 seconds ■ MIDI In/Out/ Through ■ Audio In ■ On-board joystick ■ Ports: MIDI In/Out/Through (5 pin DIN), DMX 512 (3 pin XLR), Micro-Plex (3 pin XLR), RS232 (DB9), Audio In (RCA jack) ■ Power: 12-15V DC ■ Current Draw: 800 mAmps ■ Size: 18.9"x 6.95"x 2.25", 19" 4U rack mountable ■ Weight:8.1Kgs/17.9Lbs

Full line catalog of Leviton/NSI products available upon request!

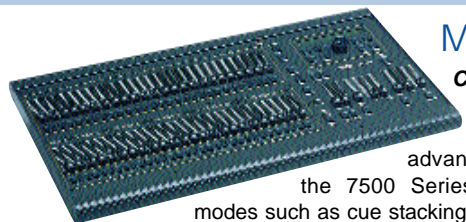

**MC 7524**  
**CT-NSMC7524**

Catering to the advanced lighting designer, the 7500 Series features operational modes such as cue stacking, level sensitive chasing and up to 512 memory scene capability. The encoder wheel and LCD readout make onboard editing quick and easy. **Specifications:** 24/48 individual control channels ■ 384 programmable memory scenes ■ 24 user programmable level sensitive chase effects ■ 2-Scene Preset or Single Scene Operation (wide mode) ■ Dual Split Dipless Manual Crossfaders ■ Soft patching ■ Auto Faders ■ Program and Modify Memory in Live or Blind Mode ■ Fully Protected Non-Volatile EEPROM Memory ■ Audio Sync to Chase Effects Mode ■ Cue Stacking ■ Universal Internal Power Supply ■ NSI 128 Channel Micro-Plex to NSI Dimmers (3-pin XLR) ■ DMX512 Digital Control (5-pin XLR) ■ MIDI In/Out/Through ■ Optional 37 pin 0-10 V ■ Analog Control Port ■ Power: 120v/240v AC ■ Current Draw: 1Amp ■ Size: 29" x 15" x 4" ■ Weight: 6.82Kgs/15Lbs

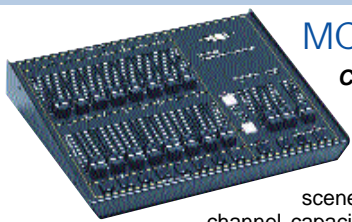

**MC 7008/16/24**  
**CT-NSMC7008**

The MC 7000 series lighting consoles are simple and flexible with three operating modes. The consoles provide standard 2-scene preset, single scene (wide mode) for 16 channel capacity, and memory scene operation. The MC 7000 series is particularly well-suited to small theaters, stage performances and rental inventories. These products are so easy to program and operate, the instructions are printed right on the consoles. **Specifications:** 8 Individual Control Channels ■ Configurable to 16 Channels ■ 8 Memory Scenes ■ 2-Scene Preset or Single Scene Operation (wide mode) ■ Dual Split Dipless Crossfaders ■ Individual Channel Bump Buttons ■ User Programmable Memory Scenes ■ User Programmable Chase Functions ■ Chase Rate Control (tap button) ■ Grand Master ■ Blackout Function ■ NSI Micro-Plex Control Signal (3-pin XLR) ■ Optional DMX512 Digital Control (5-pin XLR) ■ Power: 15v DC ■ Current Draw: 200 mAmps ■ Size: 2.75"x10.625"x9" ■ Weight: 1.48Kgs/3.25Lbs

**CT-NSMC7016** 16 channels ■ 16 scenes  
■ Size: 2.75"x16.63"x9" ■ Weight: 2.3Kgs/5Lbs

**CT-NSMC7024** 24 channels ■ 24 scenes  
■ Size: 2.75"x22.63"x9" ■ Weight: 3.07Kgs/6.75Lbs

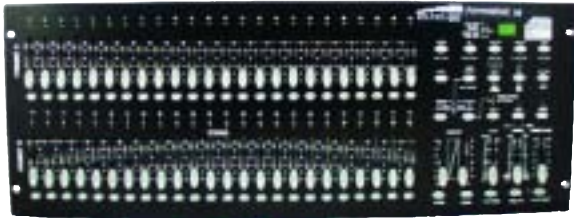

## COMMANDER 48

48 channel light-desk  
CT-COMMAND48

**Specifications:** 2 presets of 24 channels or 1 preset for 48 channels ■ Flash on each circuit ■ 4600 memories, 48 preset sequences ■ Fade/crossfade without dipping ■ Real-time or delayed scene programming ■ Sequence speed and editing time control ■ Internal memory backup ■ Multi-sequence mixing PCB ■ Music detection: audio jack sound activation and microphone for sound level control ■ Manual sequence start via Tap sync ■ Scene and sequence start with MIDI function ■ DMX 512 output channels with 3-pin XLR ■ Power supply wall transformer (DC9v-12v, 500mA) ■ Steel body and metal front panel ■ Size: 27.95"x10.47"x3.75" ■ Weight: 6.2Kgs/13.67Lbs

## OPERATOR

CT-OPERATOR



■ Controls 192 channels ■ Use with up to 12 fixtures of 16 channels ■ 30 banks of 8 scenes for a total of 240 memories ■ Programmable chases ■ 8 sliders for channel adjusting ■ 4 digit LED Display ■ Black-out key ■ Speed and fade time sliders ■ DMX 512 output 3 Pin XLR with polarity switch ■ Audio input via built in microphone ■ Audio sync with tap tempo ■ Midi In for additional triggering ■ Size: 19"x5.25"x2.95"

## Lite-Puter

### DIMMING CONSOLE CT-CX12

■ 96 control channels on 24 faders with 4 page patch ■ 96 scenes and 24 chaser programs ■ 64 step capacity per program ■ LCD Display ■ Two sub-masters cross-fading and master level ■ DMX 512 output patchable & first 24 channel in analog 0/10vDC ■ Variable speed chase & audio input ■ Gooseneck light included ■ Size: 19"x14"x4.9" 8 Rack spaces

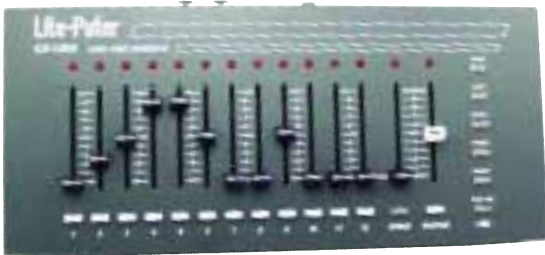

CT-CX1203



CT-CX803

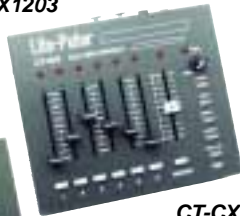

CT-CX603



CT-CX403

## CT-CX SERIES

The CX series lighting boards are simple and flexible making them suitable for small theaters, musician stage performances and rental inventory. These provide the easiest way to control several dimming channels using DMX.

### Specifications for all models:

- Individual channel level control
- Scene memory
- Master level control
- Bump/Flash button per channel
- Chase with audio input or manual speed/rate setting
- DMX512 output via both 3 and 5 pin XLR connectors
- Audio input via 1/4" jack
- Blank/pause function
- Power input: 12vDC, 1 amp

**CT-CX403** 4 Channels, 4 scene memories ■ Size: 7.87"x6.7"x2.2" ■ Weight: 1.1Kgs/2.42Lbs

**CT-CX603** 6 Channels, 6 scene memories ■ Size: 7.87"x6.7"x2.2" ■ Weight: 1.1Kgs/2.42Lbs

**CT-CX803** 8 Channels, 8 scene memories ■ Size: 9.33"x6.7"x2.2" ■ Weight: 1.2Kgs/2.65Lbs

**CT-CX1203** 12 Channels, 12 scene memories ■ Size: 15"x6.7"x2.2" ■ Weight: 1.5Kgs/3.3Lbs

## COMMANDER 24

24 channel light-desk  
CT-COMMAND24



**Specifications:** 2 presets of 12 channels or 1 preset for 24 channels ■ Flash on each circuit ■ 4600 memories, 48 preset sequences ■ Fade/crossfade without dipping ■ Real-time or delayed scene programming ■ Sequence speed and editing time control ■ Internal memory backup ■ Multi-sequence mixing PCB ■ Music detection: audio jack or microphone for sound level control ■ Manual sequence start via Tap sync ■ Scene and sequence start with MIDI function ■ DMX 512 output channel with 3-pin XLR ■ Steel body and metal front panel ■ Power supply wall transformer (DC9v-12v, 500mA) ■ Size: 18.9" x 10.43" x 3.54" ■ Weight: 4.6Kgs/10.14Lbs

## DMX MASTER II

Light-desk for dedicated projectors  
CT-DMXMASTER2



**Specifications:** 240 output channels ■ 12 dedicated projectors ■ Maximum of 20 channels per projector ■ 30 banks of 8 scenes ■ 240 preset scenes ■ 6 preset sequences ■ Fade time function ■ 2 Jog wheels for pan/tilt control ■ Black-out function ■ Preset musical tempo using speed or Tap Sync ■ Individual access to all parameters on each light ■ Quick access to all scenes, sequences and macros ■ Illuminated 2 Line LCD screen display of all functions ■ Internal memory backup ■ Music detection: Audio jack sound activation or microphone for sound level control ■ Scene and sequence start with MIDI function ■ DMX output on 3-pin XLR ■ Steel body and metal front panel ■ Power supply wall transformer (DC9v-12v, 220mA) ■ Size: 18.9"x5.25"x3.25" ■ Weight: 2.5Kgs/ 5.5Lbs



# PILOT 3000

## CT-PILOT3000

PILOT 3000 is a sophisticated DMX controller ideal for controlling large and small lighting systems. PILOT 3000 can control up to 1024 DMX channels via two independent DMX outputs. Using the PILOT 3000 is simplified by the logical layout of its controls and the use of sophisticated facilities, including: Color TFT touch screen for direct access to the functions displayed; 4 encoder wheels for controlling the parameters of the Palettes during editing, programming or for assigning values in the program's various screens; Joy Ball for Pan/Tilt. The on-board software and comprehensive connectors enable major communication protocols (DMX 512, MIDI, SMPTE) to be handled. PILOT 3000 can be connected via Ethernet, and is connected to PCs via a USB port.



Powerful graphical user interface for rapid programming and easy control ■ 5.7" color TFT Touch Screen Display monitor with 320X240 resolution ■ Additional LCD rear-lit 80-digit display of fader settings ■ 6 completely configurable scene control faders ■ 1024 DMX Channels on 2 independent ■ XLR 5-Pin lines for control of either automated fixtures or dimmers ■ Independent DMX XLR 5-pin Input ■ 10 programming function keys ■ 20 keys for direct access to playback registers ■ Playback of a max of 20 cue-lists simultaneously ■ Maximum 999 cues for each playback register ■ Maximum number of cues storable per show: 6000 ■ Advanced Shape Effect Engine ■ Personality fixture library, updateable by user ■ 64MB outboard memory on compact flash card ■ 4 encoder wheels for controlling attributes during programming and control of effects during playback ■ Grand Master fader + DBO key ■ Joyball for PAN and TILT control with 'locks' and 'fine' buttons ■ Built-in microphone ■ Two LED light USB ports ■ Aux Input ■ SMPTE Input - 3 Pin XLR ■ MIDI In/Out/Thru - 5 Pin Din ■ Audio Input using 1/4" RTS connector ■ USB connector ■ USB connection ■ Connector for Compact Flash drive ■ Power: Universal 85-265v switching power supply ■ Size: 5.31"x19.8"x19.8" ■ Weight: 4 Kg/8.8Lbs

# PILOT 2000

## CT-PILOT2000

Pilot 2000 is an extremely versatile universal DMX controller, ideal for a vast range of applications: from concerts to theatre, clubs to television studios, small to large show events. Compact, but with the performance of a large desk, Pilot 2000 controls 512 freely configurable DMX channels. Pilot 2000's clear, user-friendly control panel ensures a simple, direct and plain English approach to programming. Logical operating areas and easily accessible controls make the board perfect for live operation. Easily control intelligent fixtures with dimmers in one work space. Firmware, fixture templates and programs can be added, modified, and saved easily via RS232. A complete series of connections (DMX Out, Audio In, RS-232, SMPTE In and MIDI In/Out/Thru) make the Pilot 2000 a versatile control center for both small and large installations. Pilot 2000 is housed in a 4U rack module, facilitating installation or handy desktop use.



Compact controller with easy to read display for desk top or rack mount ■ 512 DMX channels, up to 40 fixtures 192 dimmer channels ■ Download or create fixture templates containing up to 36 channels ■ Pan/Tilt control with cursor buttons or joystick with axis lock-outs ■ Direct access to lamp, reset and other functions ■ Instant access to 4 x 40 program elements with 20 multifunction buttons ■ Up to 4 program elements can run at the same time with selectable preference ■ Trigger via Time, Tap, 4 selectable bands with Line or int. Mic, SMPTE or MIDI ■ Back-up and update all features and functions via RS-232 ■ DMX out via 5-pin XLR ■ Power: 120/230v ■ Current Draw: 2 Amps ■ Size: 2.95"x18.98"x8.75" ■ Weight: 3.8Kgs/8.36Lbs

# FOOT SCENE CHASER CONTROL

## CT-F402

■ 4 On/Off foot switches ■ Blackout ■ Master and channel level controls ■ 4 scene selection ■ Chaser: 4 programs ■ Variable chase by speed control or audio trigger ■ Outputs 0/10v ■ Size: 16.7"x7.9"x2.76"



# TOUCH PANEL

## CT-T1202

■ 12 Channel outputs on DINs and DB connector ■ 24 Touch Sensors: "Hold" and "Flash" ■ 3 chasing control sets: 1-4, 5-8, 9-12 ■ Dual color led display ■ Output 0-10V DC ■ Variable speed chase ■ Power: From pack or external DC ■ Size: 19"x3.5"x2.4" ■ Weight: 1.36Kgs/3Lbs



# DMX TOUCH PANEL

## CT-TX1201

■ Controls 12 channels directly ■ Dual signal output: DMX512 and 12 channels of 0-10vDC analog ■ One touch pad per channel ■ Auto Chasing: 3 zones of 4 channels each ■ Chase speed or audio advance ■ 12 scene memories of 12 steps each ■ DMX output on 5-pin XLR ■ Analog output via 15-pin D-sub connector ■ 19" rack mountable (2U) ■ Power input: 12-16vDC 1A ■ Size: 19"x3.46"x2.75" ■ Weight: 1.8Kgs/4Lbs



# SMART

## CT-SMART

Smart Control is a new two channel DMX controller that enables the remote control of the main functions of the Flasher DMX 1.5. Smart Control can be used in either manual or automatic mode. In manual mode, pressing the appropriate button sends the values set with two special faders to the corresponding DMX channels of the Flasher DMX 1.5. In automatic mode, the values set with the faders are sent with a frequency and duration programmed using two dedicated potentiometers. DMX out via 5-pin XLR ■ Power: 9v battery or wall transformer ■ Size: 1.89"x6.65"x2.83" ■ Weight: .45Kg/1Lbs



Specifications are subject to change without notice.

# REGIA 2048 CONSOLES

SGM Regia 2048 lighting control consoles are extremely popular with lighting operators and designers throughout the world for their versatility, ease of use and reliability. SGM consoles combine a clear user-friendly control panel and a constantly updated operating system with stylish and sturdy hardware. SGM lighting control consoles - just switch them on and you're ready to start working: with just a glance you can check the status of any moving head fixture, scanner, color-changer, dimmer or conventional fixture. Each unit's control panel has numerous functions but is extremely user-friendly: the various work areas are clearly indicated and the controls are laid out in a logical manner, for precise effective programming of a single effect or an entire show. SGM lighting consoles take all the complexity out of typical professional lighting controls, allowing lighting designers to concentrate entirely on creativity. All Regia consoles are supplied in a roadcase.



**CT-REGIA2048L  
LIVE**

LIVE



**CT-REGIA2048O  
OPERA**

OPERA



**CT-REGIA2048P  
PRO**

PRO



*Monitors not included.*

- All Regia 2048 model specifications:**
- Interchangeability from one model to the other
  - 2048 DMX channels
  - 4 Independent DMX lines
  - Includes WYSIWYG Console Edition (PC required)
  - Shape engine
  - Personalities library for all major fixture models
  - Self creation of fixture profiles
  - Fast access to groups, fixtures, palettes
  - Unlimited multi-part cues
  - Motorized A & B masters
  - Track ball / Mouse
  - 4 Encoders
  - 11 Function keys
  - PC mouse & keyboard input
  - Built-in CD-RW drive
  - Built-in Hard Disk
  - 3.5" Disk drive
  - RS-232 Out
  - Printer Out
  - MIDI In / Out / Thru
  - SMPTE In
  - Ethernet connection
  - 2 External SVGA video ports
  - Internal UPS power backup built-in
  - Internal data back up
  - Power input via Neutrik PowerCon connector
  - Power: auto sensing 90-250vAC-50/60Hz

Regia 2048 Pro <b>CT-REGIA2048P</b>	Regia 2048 Opera <b>CT-REGIA2048O</b>	Regia 2048 Live <b>CT-REGIA2048L</b>
-	-	1x12" Touch Screen monitor
-	-	1x12" TFT monitor
-	96 Manual Presets	24 Manual Presets
24 Playback Registers	24 Playback Registers	12 Playback Registers
Size: 27.2"x22.25"x6.5"	Size: 47.2"x22.25"x6.5"	Size: 41"x22.25"x7.9"
Weight: 24Kgs/52.8Lbs	Weight: 35Kgs/77Lbs	Weight: 37Kgs/81.4Lbs



WYSIWYG by Cast software is the industry standard lighting design and simulation software. WYSIWYG will provide paperwork, renderings, photometrics and layout for virtually all lighting products. An entire suite of software and hardware is available from Techni-Lux. WYSIWYG CE consoles can also be upgraded to full release versions.  
**CT-WYSIWYG-D** Design edition - Full design suite and library including rendering and layout  
**CT-WYSIWYG-P** Perform edition - All of the features of Design edition plus console compatibility

Specifications are subject to change without notice.





**DIMMER/CHASER  
PD-PACK1**

Exceptional value is what you get with the PD-PACK1 dimmer pack. Set the starting address using the LED display, connect the DMX line and off you go! Great for small bands and mobile disc jockey systems running 300, 500, 1000 watt par-cans. Also has 16 built-in chase programs for stand alone operation.

**Specifications:** DMX 512 addressable ■ 4 Individual Dimmer Channels ■ 8.3 Amps per channel ■ Maximum total load 20 Amps ■ Independent 10 Amp fuses per channel ■ 16 built in chase programs ■ Functions: Manual dimmer, manual program, auto program ■ For resistive or inductive loads ■ Multiple pack linking in/out ■ Input/output via 3-pin XLR ■ Digital LED display ■ 4 dual Edison receptacle outlets ■ 2 inch bar mounting ■ 3/8" clamp mounting holes ■ 4 Physical channels ■ 1, 2 or 4 Logical channels ■ 1000w max per channel ■ Size: 10.25"x7.5"x3" ■ Weight: 2.6Kgs/5.75Lbs



**NSI DIMMER PACK**

**PD-NSND4600**

**Specifications:** 4 channel dimmer pack ■ 4 double Edison outlets at 600w maximum ■ NSI Micro-Plex 3 pin XLR control input ■ Pack start address selectable ■ LEDs for channel level indication ■ Internal fuse protection ■ 160 micro-second choke filters to reduce audio interference ■ Power: 120v-50/ 60Hz ■ 20 amp max capacity ■ Size: 8"x9.5"x3.5" ■ Weight: 3.41Kgs/ 7.5Lbs



**4 CHANNEL AUDIO CHASER  
PD-A407**

**Specifications:** 8 Amps x 4 Channels Inductive Load, total 15A maximum draw ■ Full Wave Zero-Crossing Circuit ■ Speed: Sound to Light or Manual ■ 16 pattern selection ■ LED output indicators ■ Full on bump button ■ Single edison outputs ■ Power: 120v 50/60Hz ■ Size: 8.95"x3.5"x3" ■ Weight: 1.36Kgs/ 3Lbs



**4 CHANNEL DIMMABLE CHASER  
PD-A408**

**Specifications:** 10 Amps x 4 Channels Inductive Load ■ Dimming fader provided (Total 15 Amps Max) ■ Sudden Current Protection ■ Chaser: 16 Patterns Selectable via 4 switches ■ Speed: Built in Mic. Sound to Light or Manual ■ 4 manual flash buttons & Full On button Override ■ Audio sensitivity adjustment 4CH. Audio Chaser ■ Power: 120v ■ Size: 9.45"x3.47"x2.92" ■ Weight: 1.36Kgs/ 3Lbs



**DIMMER HALF RACK**

**PD-DX404**

**Specifications:** 5 amp x 4 channel single edison outputs ■ Maximum 5 amps per channel with a 15 amp total draw ■ DMX512 using 3 pin XLR ■ Advanced C3 dimming curve ■ LED display for DMX addressing, settings and channel output status ■ Channel bump test buttons ■ Lamp warm up feature ■ Power: 100-120v 50/60Hz ■ Size: 8.95"x3.5"x4.72" ■ Weight: 1.2Kgs/2.7Lbs



**POWER SYSTEM WITH FLASH BUTTONS  
PD-PC3**

The PC3 Power System with flash buttons is a complete low voltage switch system for professional mobile or club use. The system includes an 8 channel low voltage on/off and flash button controller (PD-PC3M) with 8 individual switches and a master on/off switch, an 8 remote channel power pack (PD-PC3PACK) and a 25 foot (PD-PC3EXT) connection cable. You can add another power pack so that one controller runs up to two remote power packs.

**Specifications:** 15 Amps circuit breaker ■ Built in transformer ■ (PD-PC3M) size: 19"x24"x 3.3" ■ Weight: 2Kg/ 4.4Lbs ■ (PD-PC3Pack) Size: 15.7"x3.5"x1.7" ■ Weight: 1.4Kg/ 3.08Lbs ■ (PD-PC3EXT) 25ft ■ Weight: .45Kg/1Lbs



**4 CHANNEL RACK AUDIO CHASER  
PD-A410**

**Specifications:** 10 Amps x 4 Channels Inductive Load ■ Total 15 Amps Max ■ Individually fused outputs ■ Full Wave Zero-Crossing Circuit ■ Chaser: 16 Patterns Selectable ■ Speed: Sound to Light or Manual 4CH. 16 Pattern Chaser ■ 1 rack space ■ Power: 120v ■ Size: 19"x 1.75"x 4.5" ■ Weight: 1.81Kgs/4Lbs



**A/C POWER CENTER  
PD-PC1**

A/C power center features 8 lighted switches, a 15 Amp resettable circuit breaker on the front and 8-120 volt plug sockets on the rear. Standard 19" 1U rack mount with 4 foot power cord. Features an additional un-switched outlet on the front. **Specifications:** Size: 19"x3"x1.75" ■ Weight: 1.59Kgs/3.5Lbs

**TOPAZ SERIES** High density dimming and small footprint packages for versatile, powerful, yet cost-effective performance. From theatrical to architectural environments, these compact and rugged designed dimming cabinets are ideal for permanent installation in a wide array of facilities. Available in wall pack 12 or rack 24.



**PD-NSTZ12W** Topaz 12 wall pack houses six plug-in dimmer modules. Size: 145"x14.25"x19" ■ Weight: 18.1Kgs/40Lbs

**PD-NSTZ24R** Topaz 24 rack houses twelve plug-in dimmer modules. Size: 14"x21.5"x9" ■ Weight: 25.9Kgs/57Lbs

**General Specifications:** Plug-in Dimmer Modules ■ Plug-in Electronic Control Module ■ Lightweight ■ Single or Three Phase Power ■ No Disassembly or Reassembly in Installation ■ Multiple Racks may be Bussed Together (Pre-assembled at the Factory) ■ Locking Door Prevents Unauthorized Access ■ Multiple Voltages ■ Low Noise Fans ■ Terminals Provided and Labeled for All Control Circuits ■ UL & CSA Listed



**TOPAZ CONTROL MODULE  
PD-NSTZCM**



One control module is required per Topaz rack.

**TOPAZ DIMMER MODULES  
PD-NSTZDM24K**



Dimmer modules available in 120 volt dual 1.8kw and 2.4kw capacities. Order filler modules when leaving any slot empty.

**ARCHITECTURAL WALL  
DIMMER PACK  
PD-NS2408CD**

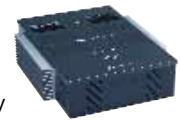

- 8 Individual dimmer or relay switch channels
- 2,400 Watts per channel - 19,200 watts maximum
- Dual SCR circuit design
- Toroidal filtering reduces audio interference
- 400 micro-second rise time
- Microprocessor controlled
- 8 Fully magnetic circuit breakers
- 512 Channel address capable
- Operates on Luma-Net, Micro-Plex, DMX512 or 0-10v input
- Screw terminal wire block inputs/outputs
- UL Listed
- Power: 120/240 Volt operation
- Size: 16.75"x20.25"x5"
- Weight: 28.12Kgs/62Lbs

Specifications are subject to change without notice.



## DMX DIMMER RACK

### PD-DX626

■ 6 channel dimmer pack, 2400 watts each ■ Slider controls on unit for manual setting ■ Selectable dimming or switching ■ DMX512 input on 5-Pin XLR isolated ■ DMX start address selectable ■ LED display for function status and test buttons ■ Built in test chase program ■ Dimming level test and warm-up selectable for each channel ■ Square (C2) or Linear (C3) dimming curve selectable ■ 6 resettable circuit breakers ■ Rear panel with dual edison NEMA 5-15 plug outputs ■ Terminal block power input ■ Power: any from 90-240VAC, 45-63Hz Single or 3 Phase ■ Size: 19" x 3.5" x 11.81" ■ Weight: 8Kgs/17.6Lbs



## DMX DIMMER RACK

### PD-DX1220TB

**Specifications:** ■ 12 channel modular dimmer pack, 2400 watts each ■ Hot swappable pull-out modules ■ Selectable dimming or switching per channel ■ DMX512 input/output on 5-Pin XLR isolated ■ DMX start address selectable ■ LED display for function status, voltage and temperature readings ■ Buttons for test and function selections ■ Built in test chase program ■ Internal 6 scene memory and adjustable fade time ■ Dimming level test and warm-up selectable for each channel ■ Channel output limiting ■ Square or linear dimming curve selectable ■ 12 resettable circuit breaker module with noise filters ■ Rear terminal connection panel ■ Analog 0/10v inputs & termination switch ■ Temperature controlled ventilation fan ■ Power: any from 90-240VAC ■ 45-63Hz Single or 3 Phase ■ Size: 19"x6.93"x10.25" ■ Weight: 19.5Kg/43Lbs



Specifications are subject to change without notice.

## DMX DIMMER PACK

### PD-DX401A

4 Channel Dimmer, 1200 watts per channel ■ Dual edison plug output per channel ■ Total pack power output 3600 watts / 30 amps ■ Two 120vAC power cord inputs ■ DMX input/output using 3 pin XLR ■ Resettable 10A circuit breakers per channel ■ Automatic warm up function to protect loads ■ Manual bump buttons ■ Selectable to dim or switch channels ■ Auto frequency tracking ■ Channel dimmer test and monitor channel value on display ■ LED digital display ■ DMX start address setting ■ Advanced C3 linear dimming curve ■ Includes truss mount plate for clamp attachment ■ Size: 8.7"x10.24"x2.75" ■ Weight: 3Kgs/6.62Lbs



### PD-DX402A

4 Channel Dimmer, 1200 watts per channel ■ Dual edison plug output per channel ■ Total pack power output 3600 watts / 30 amps ■ Two 120vAC power cord inputs ■ DMX input/output using 3 pin XLR ■ Resettable 10A circuit breakers per channel ■ Automatic warm up function to protect loads ■ Variable level sliders for manual setting ■ Selectable to dim or switch channels ■ Auto frequency tracking ■ Channel dimmer test and monitor channel value on display ■ LED digital display ■ DMX start address setting ■ Advanced C3 linear dimming curve ■ Includes truss mount plate for clamp attachment ■ Size: 8.7"x10.24"x2.75" ■ Weight: 3Kgs/6.62Lbs

## NSI/LEVITON SATELLITE DIMMER PACKS

### PD-NSDDSXXXX

The DDS series provides Leviton Micro-Plex system connect technology along with 0-10vDC analog control capability. DMX512 is an available option. All packs can be set to dim or switch mode and are U.L. listed. Series specifications: 4 channels ■ Dual SCR design ■ Selectable start address dip switches ■ External fusing ■ Toroidal filtering to reduce audio interference ■ User selectable switch or dim mode ■ Soft start operation ■ External circuit breaker ■ Power ON LED indicator ■ Internal sequence and rate adjustment ■ Control status LED ■ Individual channel LED indicator ■ NSI 3-pin XLR micro-plex in/out ■ Power: 120v 50/60hz

**PD-NSDDS5300:** 300 watts per channel ■ single Edison output ■ 100 micro-second rise ■ internal hanging bracket ■ Size: 6.6" x 9.8" x 2.6" ■ Weight: 1.81Kgs/4Lbs

**PD-NSDDS5600:** 600 watts per channel ■ single Edison output ■ 160 micro-second rise ■ internal hanging bracket ■ Size: 8.25" x 9.8" x 2.6" ■ Weight: 3.18Kgs/7Lbs

**PD-NSDDS6000:** 1200 watts per channel ■ 2400 watt maximum ■ dual Edison outputs ■ 400 micro-second rise ■ external mounting flange ■ Size: 10.9" x 9.5" x 3.75" ■ Weight: 5Kgs/11Lbs

**PD-NSDDS6000+:** 1200 watts per channel ■ 4800 watt maximum using two power cords ■ dual Edison outputs ■ 400 micro-second rise ■ external mounting flange ■ Size: 10.9"x9.5"x3.75" ■ Weight: 5.45Kgs/12Lbs

**PD-NSOPT5512:** DMX option kit to convert any DDS pack from Micro-plex to DMX512

**PD-NSN4D20-3** DMX 512 using 3-Pin XLR version

**PD-NSN4D20-5** DMX 512 using 5-Pin XLR version

■ 1200 watts per channel dimmer ■ DMX and 3-pin Microplex ■ 2400 watt maximum ■ 120v ■ dual Edison outputs ■ Individual 10a reset breakers ■ Chaser function ■ Size: 10.5"x2.625"x7.625" ■ Weight: 3.86Kgs/8.5Lbs

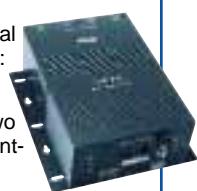

## DIMMER PACK

### PD-DX1

Single channel DMX dimmer or switch with digital address display. Dual Edison output. Truss or wall mountable. Specifications: Selectable start address ■ Dimmer preset level ■ Dimmer limit setting ■ Switch or Dimming mode ■ DMX in/out using 3 pin XLR ■ Power: 120v 50/60Hz ■ Current draw: 6 Amps ■ Size: 3.5" x 7.5" x 3" ■ Weight: 1.1Kgs/2.5Lbs

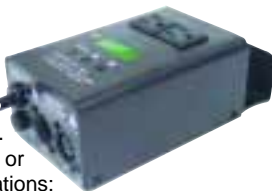

## TREEBAR PD-TREEBAR

The treebar is an 8 point hanging power rail with built in dimming controls. Mounts onto the top of a lighting tree or stand. Functions: Manual dimming, manual program, DMX control, auto program, hold and sound to light via microphone. **Specifications:** 4 channel output on 4 edison outlets ■ 1 un-switched outlet ■ 16 internal chase programs ■ 5 Amps per channel ■ 20 Amp max load ■ Resistive or inductive loads ■ Pre-heat and full-on light test per channel ■ DMX512 control by 3 pin XLR ■ DMX addressing ■ Metal chassis ■ Power: 120v-50/60Hz ■ Size: 51.3"x6.5"x3.2" ■ Weight: 5Kgs/11.02Lbs



## WALL PANELS

### LUMA NET ARCHITECTURAL CONTROL STATIONS



**CT-NS808CP**



**CT-NS408CP**

Luma-Net architectural control stations are some of the most reliable, easy-to-use wall mount controls available. They are ideal wherever cost, durability, and ease of use are major considerations and provide total lighting integration, combining house and stage lighting into one cohesive system. Five different models provide zone and scene control, as well as individual channel faders. Mount in standard wall gang electrical boxes.

**Specifications:** Control up to 100 dimmer channels ■ External lockout function ■ Programmable with Luma-Net PC Software and Interface I/F 501 or from front panel ■ Programmable fade times

**400 SERIES** - Remote Memory Control Panels with push button controls ■ Programmable Master/Slave Operation

**CT-NS400CP** Raise & lower control over 4 zones by holding a button

**CT-NS404CP** 4 Scene control with one button press

**CT-NS408CP** 8 Scene control with one button press

■ Size: 4.5"x4.5"x2.75" (2 gang deep box) ■ Weight: .45Kgs/1Lbs

**800 SERIES** - Remote Memory Control Panels with manual slide controls ■ Programmable Preset Buttons ■ All Off Button ■ Programmable On and Off scenes

**CT-NS804CP** 4 Channel slider station with On/Off programmable scenes ■ Size: 4.5"x4.5"x2.75" (2 gang deep box) ■ Weight: .45Kgs/1Lbs

**CT-NS808CP** 8 Channel slider station with On/Off programmable scenes ■ Size: 4.5"x6.4"x2.75" (3 gang deep box) ■ Weight: .9Kgs/2Lbs

## OUTSTATIONS OS1

**CT-PLOS1**



OS1 Outstation is a compact 12 Button, 60 Scene, 54 Channel DMX programmable control desk that is ideal as an architectural controller and as a remote for our ChromaZone. It is beautifully finished in stainless steel and fitted with chrome push buttons so it will fit into any decor. The OS1 is ideal for offices, bars, restaurants, foyers in fact anywhere an easy to use and program DMX controller is required. The OS1 automatically receives its 18-25VDC power from a Pulsar dimmer or ChromaZone.

**Specifications:** Size: 5.75" x 5.75" x 1.26" ■ Weight: 2.1Kgs/4.63Lbs

## PROTOCOL CONVERTER

**AC-NSOPT501**



The OPT501 is a very flexible protocol interface device with a host of different in/out combinations of the following protocols: DMX512, CMX, AMX, MicroPlex, Luma-Net, MIDI, RS232, and 0-10v analog. In addition to merging lighting protocols, this interface device is capable of converting computer protocols to lighting protocols. Features include: 512 control channel addresses, configure mode select switches, 4 line analog (0-10Vdc) or dry contact closure input port, DMX512 in/out ports in 5 pin XLR, NSI Microplex In/Out ports in 3 pin XLR, RS-232 input port via DB9 connector, NSI Luma-Net RJ-14 connector, 8 pre-programmed auto sequence chases, programmable precision auto-cue playback, and real-time ASCII control over dimmers via RS-232 ■ Power: 15vDC external power supply ■ Size: 6.9" x 4.5" x 2.5" ■ Weight: 3.3Kgs/7.1Lbs

## CONVERTER

**AC-DP3-72**



Converts DMX512 to 0/10v outputs. 72 analog output channels. Allows selection of start address. Rack mount unit. Power: 120v ■ Size: 19" x 1.75" x 9.5" ■ Weight: 3.6Kgs/8Lbs



## DMX SPLIT 4

**AC-DMXSPLIT4**

Perfect way to split and isolate DMX512 lines for protection and multiple data runs. Provides one input, one pass through and 4 isolated outputs in both 3 and 5 pin configurations. Power: 120v ■ Size: 13.2"x8.27"x3.35" ■ Weight: 2.9Kgs/6.3Lbs

## DMX SPLIT 8

**AC-DS5**

The DataSplitter 8 is ideal for the distribution of digital signals from DC to 500KHz (such as DMX, PMX, RS232, RS423, RS422, RS485 etc). Signal In/Thru is provided in addition to the 8 independent outputs, all connections are 5pin XLR. Protection on ALL inputs and outputs capable of withstanding isolation from 240V. The unit is 1U rack mount 19" or may be truss mounted using two clamps with a 10mm thread bolt.

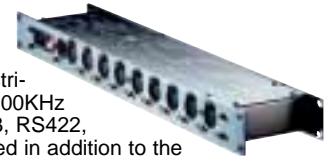

**Specifications:** Power: 12-25vDC or 100-240vAC 50/60hz ■ 1U Rack Mount 19" ■ 5 pin XLR input ■ 5 pin XLR thru output ■ 8 isolated outputs 5 pin XLR ■ On/Off power switch ■ Size: 19.1"x1.75"x4.33" ■ Weight: 1Kgs/2.2Lbs

## WIRELESS W-DMX

**AC-WDMX-S1**

Wireless DMX S-1 Blackbox Indoor Transmitter

**AC-WDMX-R512**

Wireless DMX R-512 Blackbox Indoor Receiver



The W-DMX system is a user-friendly and reliable way of transmitting and receiving DMX wirelessly. Multiple transmitters and receivers can be used in close proximity as they will not interfere with each other. The standard configuration uses 512 DMX channels, however systems can be set to support up to 16 universes or 8,192 DMX channels. The W-DMX system supports both Multi-Point and Point-To-Point operation. In a multipoint system, each DMX512 device has its own receiver, which negates the need for DMX512 cable as the entire system is wireless. In a Point-To-Point situation, W-DMX is used to 'bridge' a distance. It is easy to use with a lightweight compact size and interchangeable antennas.

The technology was invented by the US Military and is used in the GSM networks as well. It uses Adaptive Frequency Hopping Spread Spectrum (FHSS), which changes frequency 1000 times per second and uses only channels that are not used by other W-Lan and/or other products on 2.45Ghz band. Additionally, Time Division Multiple Access (TDMA) gives the user a guarantee for a much safer technology without interference.

**Specifications:** Transmission Range: with standard antenna 1km (.62 miles) ■ DMX512 using 5 pin XLR ■ Frequency Range: 2400-2483 MHz ■ One standard 2dBi antenna included ■ Approvals: CE, UL, FCC ■ Power: universal 90-250vAC ■ Current: 1 amp ■ Size: 7"x5"x1.75" ■ Weight: .77Kgs/1.7Lbs

## MICROTECH DMX TEST TOOL

**AC-DMXTEST113 (3 Pin XLR)**

**AC-DMXTEST115 (5 Pin XLR)**



This DMX tester is loaded with the features needed to solve tricky DMX problems that occur with digital dimmers, moving lights, color scrollers and virtually anything else that uses DMX. As lighting technology gets more "intelligent" so should your tools. The MicroTech is the perfect combination of powerful yet simple to use functions in an ultra-miniature package for the ultimate convenience.

**Specifications:** Display and check dimmer levels, locate dimmers that are changing levels, record up to 15 scenes into snapshot memory, Check data link for errors ■ Show number of dimmers being sent by console ■ Calculate the console's update rate ■ Automatic hands-free console backup ■ Play back prerecorded scenes ■ Edit scenes live ■ Fade and/or bump dimmer levels up and down ■ Display levels in percent, decimal or hexadecimal ■ Large LED display ■ Available with 5 pin or 3 pin XLR in/outs ■ Power: 2 x "AA" alkaline batteries or AC Adapter ■ Size: 3.97"x2.38"x1.5" ■ Weight: .22Kgs/5 Lbs

Specifications are subject to change without notice.

# LITTLITES

## LED LITTLITES



LED Technology brings new advantages to the Littlite. Long life, shock and vibration resistance along with cool operation make the Littlite LED the perfect choice for many applications.

- Excellent color rendering through the addition of red LEDs to the usual "white" LED light sources.
- Switchable red only output (Lampsets only). The Littlite LED can become a red light for unobtrusive use with no impact on the user's night vision.
- Low power - Approximately 100 milliamps at 12 volts drives the Littlite LED to full output.
- Efficient - Most of the power used by the Littlite LED is delivered to the LEDs, not a resistor.
- Long life - Over-driving seriously reduces the life of white LEDs. The LEDs in the Littlite LED are not overdriven and may be expected to remain useful for over 5000 hours of operation.
- Lifetime warranty on the mechanicals, two year warranty on the LED element.

### LED - Attached Chassis & Switch

- CAE-L12-LED** LED Gooseneck 12" - w/switch & transformer
- CAE-L18-LED** LED Gooseneck 18" - w/switch & transformer

### Individual Permanent Mount

- CAE-12P-LED** LED 12" - Permanent Mount
- CAE-18P-LED** LED 18" - Permanent Mount

### Individual Detachable with BNC connector

- CAE-12G-LED** LED 12" - BNC
- CAE-18G-LED** LED 18" - BNC

### Individual Detachable with XLR connector

- CAE-12X-LED** LED 12" - XLR 3-Pin
- CAE-18X-LED** LED 18" - XLR 3-Pin
- CAE-12XR-LED** LED 12" - XLR 3-Pin Right Angle
- CAE-18XR-LED** LED 18" - XLR 3-Pin Right Angle
- CAE-12X4-LED** LED 12" - XLR 4-Pin
- CAE-18X4-LED** LED 18" - XLR 4-Pin
- CAE-12XR4-LED** LED 12" - XLR 4-Pin Right Angle
- CAE-18XR4-LED** LED 18" - XLR 4-Pin Right Angle

### Automotive

- CAE-L9/12-LED** LED 12" Auto 12v



#### With BNC

- CAE-6G-HI** High Intensity 6" - BNC
- CAE-12G** Lo-Intensity 12" - BNC
- CAE-12G-HI** High Intensity 12" - BNC
- CAE-18G** Lo-Intensity 18" - BNC
- CAE-18G-HI** High Intensity 18" - BNC

#### With XLR 3-Pin

- CAE-6XH** High Intensity 6" - XLR 3-Pin
- CAE-12X-HI** High Intensity 12" - XLR 3-Pin
- CAE-12XR-HI** High Intensity 12" - XLR 3-Pin Right Angle
- CAE-18X** Low Intensity 18" - XLR 3-Pin
- CAE-18X-HI** High Intensity 18" - XLR 3-Pin
- CAE-18XR-HI** High Intensity 18" - XLR 3-Pin Right Angle

#### With XLR 4-Pin

- CAE-12X-HI4** High Intensity 12" - XLR 4-Pin
- CAE-12XR-HI4** High Intensity 12" - XLR 4-Pin Right Angle
- CAE-18X-HI4** High Intensity 18" - XLR 4-Pin
- CAE-18XR-4** Lo-Intensity 18" - XLR 4-Pin Right Angle
- CAE-18XR-HI4** High Intensity 18" - XLR 4-Pin Right Angle

#### With Permanent Mount

- CAE-18P-HI** 18" High Permanent Mount

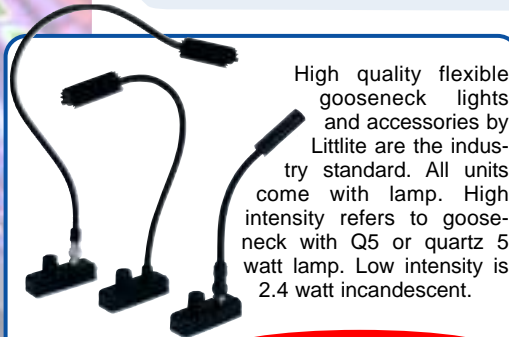

Limited Lifetime Warranty

#### Low Intensity - Attached Base

- CAE-L2/12** Gooseneck 12" w/dimmer & transformer
- CAE-L2/18** Gooseneck 18" w/dimmer & transformer

#### High Intensity - Attached Base

- CAE-L3/6** Gooseneck 6" w/dimmer & transformer
- CAE-L3/12** Gooseneck 12" w/dimmer & transformer
- CAE-L3/12A** Gooseneck 12" Hi-dimmer no transformer
- CAE-L3/12E** Gooseneck 12" Hi-dimmer & European 220v transformer
- CAE-L3/18** Gooseneck 18" w/dimmer & transformer

#### High Intensity - Detachable BNC

- CAE-L4/12** Gooseneck 12" w/dimmer & transformer
- CAE-L4/18** Gooseneck 18" w/dimmer & transformer

#### High Intensity - Automotive Types

- CAE-L9/18** Gooseneck 18" w/dimmer- 12v

*All above include a 120v transformer. To order without transformer for 12v use add an "A" to the code. For 240v add an "E" to our order code.*

## DOUBLE GOOSENECK RAKLITE

### CAE-RL10D

RL10D Raklite comes complete with two 12" goosenecks, with bright 5 watt bulbs, dimmer rheostat, 6' cord and transformer. When mounted at the top of your rack, the Raklite provides illumination for an entire rack of lighting or audio equipment. Its flexibility allows you to adjust illumination for patching or general rack service. The gooseneck is recessed into a sturdy black metal E.I.A. standard 19" wide x 1.75" high rack panel. Power: 120v using wall adapter (included) ■ Current draw: 11 watts ■ Size: 19"x1.75"x3" ■ Weight: 2.75Kgs/6Lbs

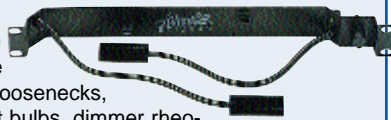

#### Parts

- CAE-CF** Color filters for high hoods: Clear, Red & Blue set
- CAE-NV/BLUE** Night Vision Color Filters, 3 blue
- CAE-NV/CLEAR** Night Vision Color Filters, 3 clear
- CAE-CP** Cigarette lighter 12v power plug
- CAE-DM** Dimming rheostat with off position
- CAE-LK** Dimmer knob
- CAE-O-KIT** "O" Rings - 12 pack
- CAE-O-KIT-X** "O" Rings X - 12 pack
- CAE-RD** Dimmer L replacement
- CAE-WXF** Wall transformer 120vAC to 12vAC 500mA
- CAE-WXF10** Wall transformer 120vAC to 12vAC for 4 high intensity 5w lamps

#### Lamps

- L64111-O** Quartz 5 watt lamp
- L1815-O** Incandescent 2.4 watt lamp

## ACCESSORIES & SPARE PARTS

### Mounting

- CAE-CL** Adjustable clip for use with L models
- CAE-HTC** High tension clamp
- CAE-MB** Magnetic base
- CAE-SM** Snap mount for L models
- CAE-WB** Weighted base for L models
- CAE-MP2** Dual mount plate for PS/DM/Permanent models

- CAE-XLR-PS3** 3 Pin panel socket for "X" series
- CAE-XLR-PS4** 4 Pin panel socket for "X" series
- CAE-XLR-PS** Panel socket BNC connector for G series

### Hoods

- CAE-HH** High intensity hood
- CAE-LH** Low intensity hood
- CAE-LX** X series hood with O-rings





## FOG MACHINE 900W

### FM-12

FM-12 is the medium sized fogger that packs a lot of punch for its size. Perfect fog machine for mid-sized venues, mobile and permanent installations requiring an output of 3,000 cubic feet per minute. Contains a 1 liter internal fluid container and one adjustable U-bracket yoke with 1/2" hole for clamp mounting. Furthermore, the fluid container is lit with a blue LED allowing quick visual inspection of the fluid level in low light environments. Features new core technology to help prevent premature heater clogging. The included remote control allows timer and variable volume output adjustments. Also included is a wireless keychain transmitter remote. The FM-12 is also controllable with DMX512. For use with water-based fog fluids only.

- Power: 120v-50/60 Hz
- Current: 8 Amps
- Control: Remote, DMX and Wireless
- Size: 12.8"x9.5"x7"
- Weight: 4.5Kgs/10Lbs
- Warm up: 5 minutes



## FOG MACHINE 1200W

### FM-13

FM-13 is a large 1200watt output machine in a compact body. Professional fog machine for large, mobile and permanent installations requiring an output of 20,000 cubic feet per minute. Features an internal 3 liter removable fluid container for easy re-filling. The fluid container is also lit with a blue LED allowing quick visual inspection of the fluid level in low light environments. Includes one handle and one adjustable U-bracket yoke with 1/2" hole for clamp mounting. Features new core technology to help prevent premature heater clogging. The included remote control allows timer and variable volume output adjustments. Also included is a wireless keychain transmitter remote. The FM-13 is also controllable with DMX512. For use with water-based fog fluids only.

- Power: 120v-50/60 Hz
- Current: 15 Amps
- Control: Remote, DMX and Wireless
- Size: 16.5"x12.3"x8"
- Weight: 6.4Kgs/14Lbs
- Warm up: 10 minutes

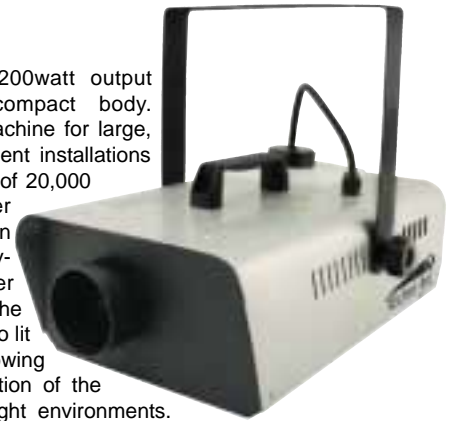

## FOG MACHINE 1500W WITH LCD REMOTE

### FM-10

FM-10 is the latest fogger which offers the most output in a stylish case. Professional fog machine for large, mobile and permanent installations requiring an output of 20,000 cubic feet per minute. Contains a 6 Liter removable fluid container and two handles. The digital LCD remote control allows duration, interval and variable output adjustments. The FM-10 is also controllable with DMX512. For use with water-based fog fluids only. Power: 120v-50/60 Hz ■ Current: 14 Amps ■ Size: 24.4"x11.8"x8.27" ■ Weight: 15Kgs/33 Lbs ■ Warm up: 12 minutes

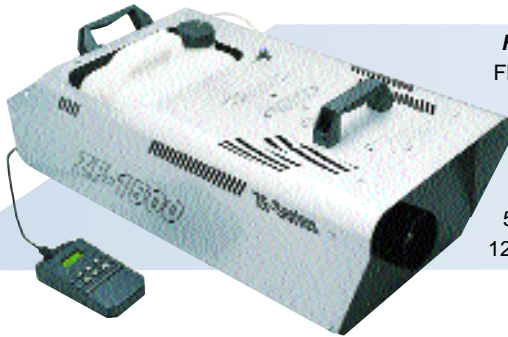

## FOG MACHINE 700W WITH REMOTE

### FM-11

This is our smallest and most affordable mobile fog machine. Its rounded profile is compact and lightweight. Features a bracket for hanging on truss, a remote switch with 10 ft. of cable and .8 liter internal fluid tank. Enhanced 3,300 cubic feet output per minute. Designed for small bands, DJ's and small venues. For use with water-based fog fluids. Power: 120v-50/60Hz ■ Current: 7 Amps ■ Size: 13"x6.29"x5.1" ■ Weight: 4Kgs/8.8Lbs ■ Warm up: 4 minutes



## FOG MACHINE 1000W WITH REMOTE

### FM-9

Super high output fog machine in new two-tone stylish body, capable of producing 10,000 cubic feet of thick fog per minute, saturating any venue quickly. Designed for mobile applications with an easy carrying handle and internal container that can hold 1.5 liters of water-based fog fluid. Includes a 30-foot remote with timer/interval function. Power: 120v-50/60 Hz ■ Current: 10 Amps ■ Size: 16.9"x8.6"x5.5" ■ Weight: 8Kgs/14.3 Lbs ■ Warm up: 5 minutes



# Swefog Ultimate 2000 and 300 Haze Generators



## FM-ULTIMATE2000D

- High Output Hazer
- Extremely Low Fluid Consumption
- Built-in DMX512 Control

**The new industry standard for hazers** - no other machine offers more value for your money. It creates a safe, dry, clean and virtually invisible haze, which enhances the beams from projected lights. The machine is made with no compromises, and offers quality in every single detail.

- Haze Virtually Invisible Until It Is Illuminated
- Outstanding Hang Time, 3+ Hours
- Optional Integrated Wireless W-DMX

### Specifications:

Instant on, no warm up time ■ Continuous operation ■ Air compressor operation, no heat, no water ■ Extremely low fluid consumption (only .06 liters per hour) ■ 3 hour haze hang time ■ Stylish design and ergonomic carrying handle ■ Integrated DMX or stand alone control ■ One DMX channel control ■ Quick DMX address using digital display ■ Swefog V-tec type B 3 way high output vapor splitters ■ Swefog EC EasyClean nozzle and filter unit ■ Hydro-glass haze filter to recycle haze fluid back into tank ■ Five independent filter systems insures clean and safe haze ■ Auto-drain of condensation in air filter ■ Easy to read fluid level indicator ■ Long life Nexus piston compressor (MTBF 8000+ hours) ■ Air intercooler made with aluminum & copper ■ Forced ventilation by fan ■ Usually does not affect most fire alarm sensors ■ Size: 8"x15.1"x15.2" ■ Weight: 18.5Kgs/40.8Lbs

**Options: Add integrated Wireless W-DMX**

Specifications are subject to change without notice.

## FM-ULTIMATE300D

The all-new Ultimate 300 combines the superior haze quality from a cracker hazer with the quiet operation of an ordinary hazer. The compressor and haze units are able to separate, and by using an extension tube the compressor is able to be hidden away for the ultimate in quiet operation. Comes with one 18" hose and one 32.8' hose.



- Hazer Weight: 9.2Kgs/20.24Lbs
- Hazer Dimensions: 8"x15.95"x12.68"
- Compressor Weight: 14Kgs/30.8Lbs
- Compressor Dimensions: 8"x15.95"x11.7"

### General Specifications:

- Fluid type: oil based haze
- Tank capacity: 2.5 liters (40 hours of runtime)
- Operation: continuous
- Comfortable carry handle
- Power: 120v-60Hz
- Current draw: 4.9 amps
- Warranty: 2 years
- Color: black

## HAZER Z300 w/ REMOTE



### FM-HAZERZ300

The Hazer Z300 is a haze generator that produces a translucent medium to maximize and enhance beams of light without creating clouds of smoke. It uses a water-based fluid which is safe, easy to use, and does not leave any residue or sticky deposits on surrounding surfaces and lighting equipment. Produces approximately 2000 cubic feet per minute. It is virtually silent and provides an even dispersal of haze. Included remote controls the manual or automatic ON/OFF operation and the variable interval timer setting. One liter internal fluid tank. Power: 120v-50/60Hz at 6 Amps ■ Size: 20.7"x8.2"x9.25" ■ Weight: 8.9Kgs/19.6Lbs

## HAZER Z150 w/ REMOTE

### FM-HAZERZ150

The Hazer Z150 is a compact haze generator that produces a translucent medium to maximize and enhance beams of light without creating clouds of smoke. It uses a water-based fluid that is safe, easy to use, and does not leave any residue or sticky deposits on surrounding surfaces and lighting equipment. Produces approximately 1000 cubic feet per minute. It is virtually silent and provides an even dispersal of haze. Included remote controls the manual or automatic ON/OFF operation and the variable interval timer setting. Internal fluid tank. Power: 120v-50/60Hz at 4 Amps ■ Size: 15"x7"x6" ■ Weight: 3.9Kgs/8.5Lbs



## HAZER 1 FM-HAZER1

Hazer1 is a revolutionary progress in fog machines for special effects. It produces a thin translucent haze with the longest hanging time. In addition a new technology of haze transfer conserves fluid consumption. Hazer is equipped with a high quality and efficient air compressor, a sophisticated haze transfer system and a specially designed tank. No aluminum heater, no temperature controls, no hot air and no warm-up time is needed. Designed for instant operation and to last. Use non-toxic oil-based fluid. Timer remote is optional. Power: 120v-50/60Hz, 2 Amps ■ Size: 19.5"x9.75"x11.5" ■ Weight: 12Kg/26.4Lbs. **FM-HAZER1TR:** Optional remote. Controls time interval and duration.





# ELITE FOGGING AND HAZING FLUIDS

Elite™, Elite Pro™, Elite LL™, Elite QD™ and Elite HQD™ are high quality fogging fluids which can be used to create a white fog mist. Ranges of use include theaters, concerts, tours, clubs and all other entertainment venues where a safe, non-toxic visual medium is necessary to better define the visibility of lighting designs. The Elite™ Series of fluids are formulations of U.S.P. or high purity grade materials listed as non-hazardous by OSHA. Scientifically distilled water is used as the main component making it a water-based, low-flammable fogging fluid. By using distilled water and a filtering system, contamination of the fluid is kept to a minimal mineral concentration. Prior to filling containers, a final 1 micron dual filtering process insures a consistently pure mixture. Keeping contamination virtually non-existent helps extend the mean time between failure of fog machines thus reducing maintenance, down-time and costs.

**Elite™** - Use Elite to create medium density clouds of fog - neutral scent, scenting option available

- One Quart (0.95L)            **FF-ELITEQ**
- One Gallon (3.79L)        **FF-ELITE1**
- 2.5 Gallons (9.46L)      **FF-ELITE2**
- 5 Gallon Pail (18.93L)    **FF-ELITE5**
- 55 Gallon Drum (208L)    **FF-ELITE55**



Gallon



5 Gallon Pail

**Elite Pro™** - Performance formula - Use Elite Pro™ for higher density, longer lasting fog - neutral scent, scenting option available

- One Quart (0.95L)            **FF-ELITEPROQ**
- One Gallon (3.79L)        **FF-ELITEPRO1**
- 2.5 Gallons (9.46L)      **FF-ELITEPRO2**
- 5 Gallon Pail (18.93L)    **FF-ELITEPRO5**
- 55 Gallon Drum (208L)    **FF-ELITEPRO55**



55 Gallon Drum

**Elite LL™** - Elite LL™, when used with a cooling device (chiller) creates a low lying, quick dissipating fog effect. Without the chiller, Elite LL™ creates an extra quick dissipating fog.

- 2.5 Gallons (9.46L)        **FF-ELITELL2**
- 55 Gallon Drum (208L)    **FF-ELITELL55**



**Elite QD™** - Use Elite QD™ to create quick dissipating medium density clouds of fog.

- One Gallon (3.79L)        **FF-ELITEQD1**
- 5 Gallon Pail (18.93L)    **FF-ELITEQD5**
- 55 Gallon Drum (208L)    **FF-ELITEQD55**



**Elite EQD™** - Use Elite EQD to create extra quick dissipating clouds of fog.

- 5 Gallon Pail (18.93L)    **FF-ELITEEQD5**
- 55 Gallon Drum (208L)    **FF-ELITEEQD55**

**Elite HQD™** - Use Elite HQD™ to create quick dissipating higher density clouds of fog only.

- 5 Gallon Pail (18.93L)    **FF-ELITEHQD5**
- 55 Gallon Drum (208L)    **FF-ELITEHQD55**



Quart



2.5 Gallons

**Elite Haze™** - Elite Haze is non-toxic, odorless and offers a long lasting hang time. Elite Haze is filtered and utilizes pure grade chemicals to help prevent clogging and residue build-up. Use Elite Haze to create a finely hazed atmosphere only.

- One Gallon (3.79L)            **FF-ELITEHAZE10** oil-based
- 55 Gallon Drum (208L)      **FF-ELITEHAZE550** oil-based

- One Gallon (3.79L)            **FF-ELITEHAZE1W** water-based
- 5 Gallon Pail (18.93L)      **FF-ELITEHAZE5W** water-based

**Elite Foam™** - Use Elite Foam™ concentrate to produce 58 gallons of foaming solution. Dilute with water.

- One Gallon (3.79L)            **FF-FOAM1**

**Elite Snow™** - Use Elite Snow™ to create a high volume of fluffy foam suds that are of a non-toxic, water-based solution.

- One Gallon (3.79L)            **FF-SNOW1**
- 55 Gallon Drum (208L)      **FF-SNOW55**

## ELITE SCENTS



Add a little scent to your fog. Concentrated scents for Elite and Elite-Pro are sold separately in individual 1 ounce bottles. Each bottle will scent up to 4 gallons of fog juice.

- SCENT-S**            Strawberry
- SCENT-P**            Pina Colada
- SCENT-T**            Tropical
- SCENT-V**            Vanilla
- SCENT-E**            Euro/original scent

Specifications are subject to change without notice.

## STROBE FLASH TUBE AND CONTROLLER

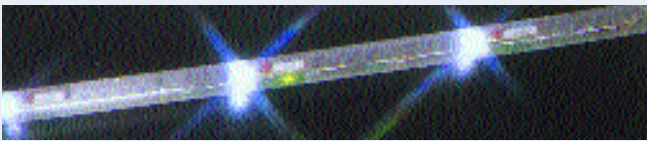

**ST-TUBE2** These dynamic strobe tubes produce long bi-directional chases of intense pulse strobing. Each tube contains 4 individually firing strobe circuits. Each tube can be chained from one to the other with included connectors. Mounting clips included. Weather resistant for outdoor use. Controller sold separately. Tube length 5' by 2" diameter. Weight: 5Kgs/ 11Lbs

### ST-TUBE2C1 Controller

Up to 25 tubes can be linked on one single controller. Offers 5 modes of operation: one way forward, one way backwards, reverse, circulation and combination mode. On/Off switch, speed and interval time control. Power: 120v-50/60hz ■ Size: 6.11"x4.33"x2" ■ Weight: 1Kg/ 2.2Lbs



## FLASHDOME STROBE

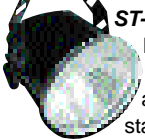

### ST-FLASHDOME1

Flashdome provides powerful flashes from a stylish molded housing. Includes mounting bracket and strobe flash variable pot adjustable from 2 to 14 flashes a second. Can run stand alone or with remote control ST-STROBEC103 or C108. Power: 120v-50/60Hz ■ Wattage: 45w with LSTBH0647 ■ Size: 13.8"x9.46"x9.46" ■ Weight: 2Kg/4.4Lbs

## OCTA STROBE

### ST-STROBE4



Octagonal strobe box with 60 watt power flashes. Includes mounting bracket and variable speed adjustment from 2 to 14 flashes per second. Optional remote: ST-STROBEC103 or C108. Power: 120v-50/60hz ■ Size: 11"x5.1"x10.25" ■ Weight: 2.4Kgs/ 5.3Lbs ■ Lamp: LSTBH0647

## HIGH POWER STROBE

### ST-STROBE3



High power 100w strobe light. Includes mounting bracket and variable speed adjustment from 2 to 14 flashes per second. Optional remote: ST-STROBEC103 or C108. Power: 120v-50/ 60hz ■ Size: 12.61"x10.24"x 9.06" ■ Weight: 5Kgs/11Lbs ■ Lamp: LSTBH0647

## MICRO STROBE BOX

### ST-MICRO1



It's small but packs a punch. Miniature strobe with 20w xenon lamp and variable speed control from 1 to 10 flashes per second. Includes mounting bracket. Size: 4.73"x3.15"x2" ■ Weight: .8Kg/1.76Lbs ■ Power: 120v-50/60Hz ■ Lamp: LSTAT367S

## HANGING STROBE

### ST-STROBEH

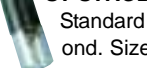

Standard AC plug with 2.5' cable. Comes in clear, flashes 1 per second. Size:1.6"x3.8" ■ Weight: 200g/ 7 ounces.

## FLASHER DMX 1.5



### ST-FLASHER1

Flasher DMX 1.5 is a professional strobe light that has a 1,500W xenon lamp with exceptional luminous power. Fitted in a sturdy powder-finish metal container, Flasher DMX 1.5 is built to ensure reliability under even the most extreme conditions. It operates on a continuous duty cycle without thermalling out. Flash rate: from 0 to 50fps (continuous light) ■ Dimmer adjustable from 0-100% ■ Single flash at maximum power ■ Universal power requirements and automatic power



## SMART

### CT-SMART

Smart Control is a new DMX remote controller for the main functions of the flasher DMX 1.5. See page 25.



and, using just 2 DMX channels, it can be controlled by any controller ■ The built-in computer constantly monitors unit status and indicates any faults ■ The Flasher is remarkably powerful, approximately three times that of others of the same category. Size: 7.87"x19.69"x8.66" ■ Weight: 6 Kgs/13.2 Lbs

## DMX SUPER STROBE

### ST-ML504B-ML



Super powerful 1000 watt DMX strobe for professional applications. DMX controllable on two channels: dimming and flash rate. Mounting bracket included. Power: 120v-50/60Hz at 14 Amps ■ Wattage: 1000w with LSTXOP70/FTW-T ■ Size: 18.5"x7.25"x7.5" ■ Weight: 3.86Kgs/8.5Lbs ■ 3-Pin XLR input

## SUPER BURST DMX STROBE

### ST-STROBE750D



Strobe 750 produces 750w bursts of xenon flashes. Using DMX control allows the varying of intensity and rate of flash speed. DMX input via 3-pin XLR connection. Mounting bracket included. Power: 120v-50/60hz ■ Size: 15.5"x10"x6" ■ Weight: 4Kgs/ 8.8Lbs ■ Lamp: LST750

## SUPER BURST STROBE

### ST-STROBE750

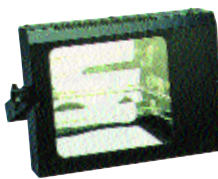

This strobe produces 750w bursts of xenon flashes. Mounting bracket included. Variable speed adjustment from 2 to 14 flashes per second. Optional remote: ST-STROBEC108 or ST-STROBE750R. Power: 120v-50/60hz ■ Size: 12.61"x11"x3.15" ■ Weight: 3Kgs/6.6Lbs ■ Lamp: LST750

## STROBE EGG

### ST-EGG



The strobe egg is a powerful and compact strobe ball which can be screwed into any standard medium screw base lamp socket. It features a variable strobe adjustment knob for flash speed and a lamp rating of over 5 million flashes. Sold with clear dome. Optional colored replacement domes are available in red, blue, green and yellow. Size: 3.9"x3.9"x3.9" ■ Weight: .165Kg/ .4Lbs



## SINGLE CHANNEL STROBE CONTROLLER

### ST-STROBEC103 ST-STROBE750R

Single channel strobe controller with adjustable speed and power on/off switch. Power: 120v-50/60hz ■ Size: 5.12"x2.56"x5.91" ■ Weight: 1Kg/2.2Lbs



## FOUR CHANNEL STROBE CONTROLLER

### ST-STROBEC108

Strobe controller outputs 4 different trigger channels. Each channel can link up to 8 strobes in series connection. Adjustable flash rate. Fits in rack. Size: 19.2"x3.75"x2.2" ■ Weight: 2Kg/ 4.4Lbs



## STROBE CONNECTION CABLES

**ST-STROBEC25:**  
25 feet 1/4" RTS cable  
**ST-STROBEC50:**  
50 feet 1/4" RTS cable  
**ST-STROBEC100:**  
100 feet 1/4" RTS cable







## DIGI-FAN WIND TUNNEL FAN

**SE-WINDDIGIFAN**

DigiFan is a powerful and versatile wind tunnel machine designed for professional TV studios, theatres, theme parks and concert venues. It is suitable for a wide range of applications including quick dispersion of fog and haze over long distances, creating special wind effects, scattering bubbles, confetti or snow, and even cooling performers during photo shoots. It is extremely compact in size and weighs only 28 pounds. The supplied magnetic remote controlled box includes DMX settings, 9 pro-

gram memory settings, speed control and turbo modes. The fan housing is constructed from a molded lightweight plastic with rugged tubular steel surroundings for transport protection and mounting. The 11" single part blade and spiral front grill create a very focused wind effect. The bracket can stand on the floor or be mounted using the 1/2 inch clamp hole.



**Specifications:** High velocity motor speed of 3500RPM ■ DMX Control: On/Off & variable speed control ■ DMX512 on 5 Pin XLR ■ Remote Control: 9 mode memory setting and variable speed fader ■ Full on touch turbo function from 0-3500RPM within 5sec ■ Air Volume: 1700CBM/hr ■ Wind Speed: 60KM/hr ■ Remote supplied w/3M standard cable, can be extended ■ Mounting: Self floor standing, or Clamp/Photo stand mountable ■ Power: 100-120v & 200-240vAC 50-60Hz w/On-Off switch on rear panel ■ Power: Max. 1200W, Current: 10A ■ Color: black ■ Size: 20" diameter x 22" height ■ Weight: 12.5kgs/27.6Lbs

## BUBBLE MACHINES

### SE-BUBBLEM1

Ideal for parties, stage shows, night clubs or just plain fun. Medium output bubble machine. Power: 120v ■ Current Draw: 1.8 Amps ■ Size: 8.75" x 8.75" x 8.5" ■ Weight: 2.9Kgs/6.5Lbs

### SE-BUBBLEM2

Ideal for stage shows, theme parks, and night clubs. High output bubble machine. Includes adjustable U-bracket and 1/2" clamp hole for mounting. Features an easily refillable and large removable reservoir for bubble fluid. Power: 120v ■ Current Draw: 1.8 Amps ■ Size: 16.5"x11"x8.5" ■ Weight: 5Kgs/11Lbs

### SE-BUBBLEM4

Our most professional bubble machine using 3 fans and 4 bubble wheels. Perfect for large areas and venues where lots of bubbles are needed quickly. Includes adjustable U-bracket and 3 x 1/2" clamp holes for mounting. Features a large stainless steel bubble fluid reservoir and side drain valve. DMX512 control using 1 on/off channel ■ DMX 5 pin XLR input ■ Dip switch addressable ■ Power: 120v ■ Current Draw: 2 Amps ■ Size: 16.5"x10"x8.3" ■ Weight: 10.4Kgs/23Lbs

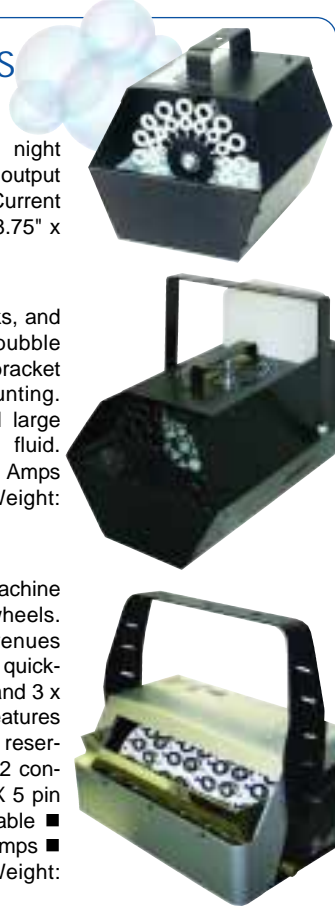

**SE-BUBBLEL1** Bubble Liquid – safe & non-toxic - 1 gallon

**SE-BUBBLEL55** Bubble Liquid – safe & non-toxic - 55 gallon drum



## SCENT MACHINES

Add a new dimension, SCENT. We have stimulated the visual senses, now we can communicate through the sense of smell with our series of aroma producing machines. Scenta machines are very simple to use. Just open drawer and pour special scent fluid onto optionally sold tray and pads, close drawer and turn unit on. Variable output control.

**SE-SCENT500** Specifications: uses one scent tray & pad ■ Size: 10"x9.5"x3.75" ■ Weight: 3.4Kg/7.5Lbs ■ Power: 120v-50/60Hz ■ Current draw: 1 Amp

**SE-SCENT1000** Specifications: uses two scent trays/pads ■ Size: 20.5"x12"x3.75" ■ Weight: 7.26Kgs/16Lbs ■ Power: 120v-50/60Hz ■ Current draw: 2 Amps

## WIND TUNNEL

**SE-WINDFAN/1**



WindTunnel 500 fan can be used whenever you need artificial wind to create a mood on your stage, studio, theater or video/photo shoot. The tunnel shaped jet engine case produces a highly concentrated narrow stream of airflow. Can be used for dispersion of fog or haze effect on stages. User can adjust speed with the variable control slider.

**Specifications:** 145 watt motor ■ 60db Noise level ■ Wind volume: 100,000 cubic feet per hour ■ Tunnel diameter: 16" ■ Internal thermal cut-off ■ Electronic speed control ■ Detachable power cord ■ Size: 20.5"x12.25"x24" ■ Weight: 11Kgs/24Lbs ■ Current draw: 2 Amps ■ Power: 110v-120v 50/60Hz



## SNOW MACHINE

**SE-SNOW1**

The Snow Machine creates a flurry of artificial snow flakes for staging, theatrical and show use. Uses non-toxic foaming liquid. Adjustable flake volume from included remote control with 30' cable. Includes 5 liter container and mounting yoke. **Specifications:** Discharges approximately 30 feet ■ DMX Control ■ Black steel plate body ■ Power: 120v-50/60Hz ■ Current draw: 10 Amps ■ Size: 21.3"x9.8"x11.2" ■ Weight: 12Kgs/ 26.4 Lbs

## FLAME EFFECT

**SE-FLAMEH120**

This special effect simulates a living flame without the dangers of a real "fire" flame. Common safety issues, like flammability, heat, fuel fumes and smoke typically associated with the use of real fire are no longer obstacles. It can be used in many applications, like stage work, theaters, night clubs, themed environments and Halloween. Hanging model features a cauldron with three chains. Creating the illusion of a flame has never been easier. Just hang it up and plug it in!

**Specifications:** 3x MR11 Lamps ■ Size: cauldron 14" diameter x 5.5" deep ■ Weight: 4.08Kgs/9Lbs ■ Power: 120v-50/60Hz ■ Current draw: 2 Amps

**Lamp codes:** Amber: *LFTD/O-I 20w 12v MR11*  
Blue: *LFTD/B-I 20w 12v MR11*

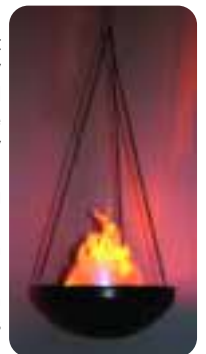

## BLACK LIGHTS



**BL-48PRO** This professional 48" black light metal fixture produces UV light using one 40w F40BLB bulb. Includes rear reflector, power cord and metal protection mesh grill. Power: 120v/60Hz ■ Size: 51.25"x5.3"x5" ■ Weight: 5.1Kgs/11.2Lbs



**BL-48** The 48" black light metal fixture produces UV light. It includes bulb, rear reflector, power cord and on/off switch. Replaceable F40BLB lamp. U.L. approved. Power: 120v/60Hz ■ Size: 48"x5.25"x2" ■ Weight: 3.86Kgs/8.5Lbs



### BL-24

The Blacklite Stik is a unique compact UV lighting unit. It is light weight with all electrical components built into the slim plastic strip. Completely self-contained and has no parts to maintain or replace. It will last 3 to 5 years under normal use. Fast and easy installation. Includes 6' cord with on/off switch. U.L. approved. Power: 120v/60Hz ■ Size: 25"x1.75"x1.75" ■ Weight: .45Kg/1Lbs



### BL-18

The 18" black light fixture produces UV light. It is light weight and includes a F15T8/BLB bulb, power cord and on/off switch. Replaceable lamp. U.L. approved. Power: 120v/60hz ■ Size: 18"x4"x1.5" ■ Weight: .77Kg/1.69Lbs



## BLACKLIGHT BULBS

Black light blue bulbs are available in a variety of styles and sizes. They produce UV light which makes objects glow. BLB bulbs are a deep purple color and emit no white light. Available in fluorescent tubes: **F40BLB, F36T8BLB, F20BLB, F8T5BLB, F6T5BLB, F4T5BLB, F15T8BLB, FCA21/BLB, H400BL.** Incandescent E26 medium screw available in versions: **40T10BLB, 50R20BLB, 75A19BLB, 75R30BLB, 100G40BLB.**

## MIRROR BALL & MOTORS

### BALLMOTORDC1

Battery operated mirror ball motor. Uses 1 D-Cell 1.5v Battery. For use with 2"-12" mirror balls only. Runs over 72 hours on one new Duracell Pro-Cell Battery. Dia: 1.75" x 5.5" ■ Weight: 96.4g/ 3.4oz



### BALLMOTOR3P

Economical mirror ball motor with plastic casing. Revolves at 3 RPM. Most popular for ball sizes from 2" to 12". Power 120v/60Hz ■ Dia: 4.75" x 2" ■ Weight: 314.7g/11.1oz



### BALLMOTOR3

Mirror ball motor for 2" to 16" mirror balls. Spins at 3 RPM. Metal housing with clamp mounting plate. Power: 120v, use BALLMOTOR3-2 for 220v. Dia: 4.25" x 3" ■ Weight: .45Kg/1Lbs



### BALLMOTORHD1

Mirror ball motor for 16" to 20" mirror balls. Maximum load capacity of 16 Lbs. Round metal housing. 3 RPM rotation ■ Dia: 4.63" x 3.25" high ■ Power: 120v/60Hz ■ Weight: .65Kg/1.44Lbs



### BALLMOTORHD2-3

Mirror ball motor for 24" size or smaller. Maximum load capacity of 20 Lbs. Round metal housing. 3 or 1 RPM rotation (specify by code) ■ Dia: 7.7" x 5.75" high ■ Power: 120v/60Hz ■ Weight: .93 Kg/ 2.05Lbs



### BALLMOTORSHD1

Super Heavy Duty mirror ball motor specifically designed to rotate our 30 and 40 inch mirror balls. Maximum load capacity of 94 Lbs. Square metal housing. 3 RPM rotation ■ Power: 120v/60Hz ■ Size: 12" x 7.75" x 7.25" ■ Weight: 4.77 Kgs/ 10.5 Lbs

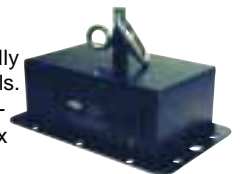

## MIRROR BALLS

High quality glass mirror balls. Motors sold separately.

Item Code:	Size:	Tile:	Weight:
<b>BALLMIRROR2</b>	2"	5mm	37g/1.3oz
<b>BALLMIRROR8</b>	8"	10mm	.9Kg/2Lbs
<b>BALLMIRROR10</b>	10"	10mm	1.36Kg/3Lbs
<b>BALLMIRROR12</b>	12"	12mm	1.81Kg/4Lbs
<b>BALLMIRROR16</b>	16"	12mm	2.95Kg/6.5Lbs
<b>BALLMIRROR20</b>	20"	15mm	4.76Kg/10.5Lbs
<b>BALLMIRROR24</b>	24"	15mm	7.26Kg/16Lbs
<b>BALLMIRROR30</b>	30"	17mm	16.1Kg/35.5Lbs
<b>BALLMIRROR40</b>	40"	17mm	28.5Kg/62.7Lbs



## BLACKLIGHT 400PRO

### BL-400

BL-400 is a compact, super high intensity 400w black light UV fixture with polished reflector and wire mesh protector.

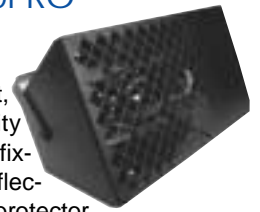

For professional use. Takes 5 minutes warm up to reach maximum brightness and provides wide dispersion coverage. Includes mounting bracket and power cord. Lamp: H400BL ■ Power: 120v/60Hz ■ Size: 7.25"x19.5"x10.25" ■ Weight: 13.2Kgs/29Lbs

## BLACKLIGHT UV 125W ROUND REFLECTOR SPOT

### BL-125S

Lamp: H125BL ■ Power: 120v/60Hz ■ Size: 8.85"x11.85"x12.75" ■ Weight: 7.7Kgs/17Lbs

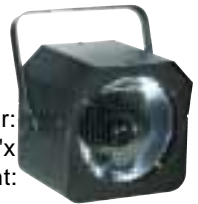

## BLACKLIGHT UV 400W ROUND REFLECTOR SPOT

### BL-400S

Lamp: H400BL ■ Power: 120v/60Hz ■ Size: 14.76"x15.27"x16.26" ■ Weight: 13.2Kgs/29Lbs





# STANDS

Specifications are subject to change without notice.

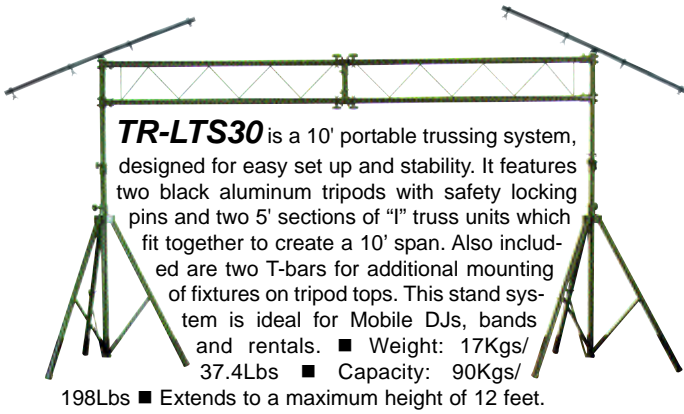

**TR-LTS30** is a 10' portable trussing system, designed for easy set up and stability. It features two black aluminum tripods with safety locking pins and two 5' sections of "I" truss units which fit together to create a 10' span. Also included are two T-bars for additional mounting of fixtures on tripod tops. This stand system is ideal for Mobile DJs, bands and rentals. ■ Weight: 17Kgs/37.4Lbs ■ Capacity: 90Kgs/198Lbs ■ Extends to a maximum height of 12 feet.

**TR-LTI** I-Truss 5' section



### TR-WINDUP2

Black wind up crank stand is adjustable from 70" to 116". Includes top cross bar. Maximum capacity: 45Kgs/ 100 Lbs ■ Weight: 13.5 Kgs/ 29.7Lbs

### TR-LTS03

Compact, light duty stand with T cross bar for hanging par-cans, pin-spots, and smaller fixtures. Easy to transport. Maximum capacity: 30Kg/66Lbs ■ Extends to 9 feet maximum ■ Weight: 1.8Kgs/4Lbs



**TR-LTS01** Heavy duty aluminum tripod stand with T bar and two side bars. Safe and economical. Easy to transport. Maximum capacity: 50Kg/ 110Lbs ■ Extends to 13 feet maximum ■ Weight: 7.94Kgs/17.5Lbs



### TR-MOONSTAND

For Moon Series Followspots - Black. ■ Weight: 8.9Kgs/ 19.5Lbs

### TR-TL4001

Professional heavy duty follow-spot tripod stand. Pivot sold separately. ■ Weight: 5.68Kgs/ 12.5Lbs

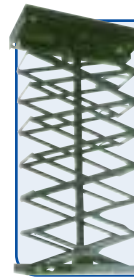

### ELEVATOR TR-EL03-LA

Elevator descends 3 meters or 9.9 feet. Maximum lift load weight is 80Kg/176Lbs. Power: 220v-50/60Hz ■ Size: collapsed 23.64"x 9.85" x12.2" ■ Weight: 42Kgs/ 92.5Lbs

## TRUSSING



### TR-TRUSS

Aluminum trussing and truss structure systems are available in many types of configurations. Box, triangular, and ladder types are available in heavy and light duty weight. Circular truss shapes, square and custom designs are possible using a variety of sizes: 6", 9", 10", 12", 18" and 24". Trusses come in natural aluminum polished or may also be powder coated to specific colors for architectural applications. Call with specific application.

Why use and lug around those heavy base weights? These lightweight aluminum base stands are perfect for par-cans and units which need to sit on the floor. A fixture is directly mounted to the floor base.



### TR-4583

**Specifications:** Color: black ■ Bolt: 3/8" ■ Diameter: 9-5/8" ■ Weight: .45Kgs/1Lbs



### TR-4584

**Specifications:** Color: black ■ Bolt: 3/8" ■ Diameter: 5-5/8" ■ Weight: .27Kgs/.6Lbs

## SAFETY CABLES



**SAFETYCABLE18B** 18" black w/lock  
**SAFETYCABLE18S** 18" silver w/lock

**SAFETYCABLE30B** 30" black w/lock  
**SAFETYCABLE30S** 30" silver w/lock

Every fixture that hangs overhead should always be equipped with a safety cable. In the event that a clamp should fail or is improperly tightened, a fixture could fall from the ceiling or truss and possibly cause personal injury or damage to equipment.

## PIVOTS



### TR-TL4007

Standard pivot attachment for the TR-TL4001 stand.

### TR-TL4014

Rotating pivot attachment for the TR-TL4001 stand. For very smooth and frictionless movements.

## TRIPODS & GRIP STANDS

Made of chromed steel.

Model:	Sections	Height min/max	Weight	Base Spread	Mount
<b>TR-4503</b>	3	41"/92"	2Kgs/4.4Lbs	42"	Baby 5/8"
<b>TR-4520</b>	2	35"/108"	3.1Kgs/6.8Lbs	45"	Baby 5/8"
<b>TR-4525</b>	3	35"/139"	3.9Kgs/8.6Lbs	45"	Baby 5/8"
<b>TR-4531</b>	2	43"/130"	5.1Kgs/11.2Lbs	61"	Junior 1-1/8"

# STAGEMAKER CHAIN MOTOR HOIST



STAGEMAKER COMPACT concert hoists run double duty for both concert staging and theatrical productions. R&M designed them to be small enough to fit into truss structures, quiet enough to run during theatrical performances, lightweight and durable enough for rigorous touring, and strong and accurate enough to position speakers, lighting systems, stage sets, and sceneries. R&M continuously consults entertainment industry professionals on what they need from their staging equipment and how best to improve the STAGEMAKER COMPACT line. The results have led to such features as a planetary gearbox utilizing grease lubricated precision gearing, which gives STAGEMAKER COMPACT hoists an average dB rating of less than 75dB; a large integral steel panel encasing all electrical components while giving you both easy access for maintenance and room for modifications; a heat treated load wheel with five full pockets to both minimize chain stress and ensure smooth operation; a chain guide to prevent the grade 80 black load chain from jamming no matter what position the hoist is in; a body of pressure-molded aluminum, which reduces the hoist's weight; heat sink ribs on the motor body for heat dissipation that lets you perform up to 240 starts per hour; folding handles for easy transport; 80-micron dark epoxy paint for added protection. Because of these features, STAGEMAKER COMPACT hoists are great basic workhorse chain motor hoists for everyday staging work.

**Specifications/standard components:**

Class F insulated Hoisting Motor ■ Combined load limiter/brake ■ Electromechanical diskbrake ■ Solid-state brake control ■ 360 upper/lower hook rotation ■ Canvas chainbucket ■ Upright and inverted use\* ■ Pressure cast aluminum body ■ 5-pocket load wheel ■ Anti-jam chain guide ■ Flexible handgrips ■ Black two-part epoxy paint ■ Power supply 115V 1ph 60Hz or 208,230, or 460V 3ph 60Hz \*SM1 models only

Some STAGEMAKER COMPACT models available (For full list and additional options, contact Techni-Lux.)

Capacity	Product Code	Speed - 60Hz		Falls	Chain Size (mm)	Motor Power - 60		Dimensions	Weight (Without chain)
		m/min	fpm			kW	Hp		
1/8 Ton	MO-CH012-1P	9.6	32	1	3.1x9.3	0.24	0.33	278mmx200mmx110mm 10.8"x7.8"x4.3"	14kg/30.8lbs
1/4 Ton	MO-CH025-1P	4.8	16	1	4.8x12.5	1	1.33	401mmx247mmx135mm 15.7"x9.6"x5.26"	23kg/51lbs
1/2 Ton	MO-CH050-1P	4.8	16	1	4.8x12.5	1	1.33	401mmx247mmx135mm 15.7"x9.6"x5.26"	23kg/51lbs
1 Ton	MO-CH0100-3P	4.8	16	1	6.8x17.8	2.1	2.8	483mmx281mmx175mm 18.9"x11"x6.82"	47kg/104lbs

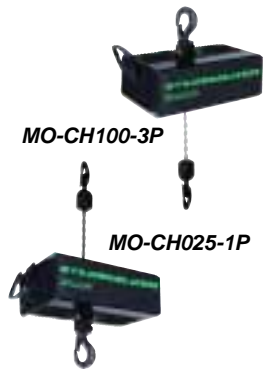

Product Code	Type	Phase	Output	Control Range
MC-401-7P	4-way Motor Controller	Single Phase CS63-75 Input	7 pin Socapex	50 foot remote
MC-403-7P	4-way Motor Controller	Three Phase CS83-75 Input	7 pin Socapex	50 foot remote
MC-801-7P	8-way Motor Controller	Single Phase CS63-75 Input	7 pin Socapex	50 foot remote
MC-803-7P	8-way Motor Controller	Three Phase CS83-75 Input	7 pin Socapex	50 foot remote
MC-PICKLE/L14-20	Pickle for Chain Motor Control	N/A	L14-20 Male	1.5 foot tail & L14-20

## AIRWALL HANGERS

**CLAMP-AIRWALLHANG**

Alumalok is the industry standard for airwall track rigging. It is a tool for professional riggers, and for audio and video technicians trained in rigging for their specific applications. Utilize the built-in airwall track found in hotels, meeting rooms and venues around the world to hang lighting, speakers, cables, decor and more. Forget the time consuming hassles of more complicated rigging points and chain motors. Load rated at 750 lbs (340 kgs) UDL.



**CLAMP-AIRWALLBLOK**

AlumaBlok is designed as your number one solution for cable picks, wire rope assemblies and speaker dead hangs from airwall tracks. Load rated at 500 lbs (227 kgs) UDL this is the middle man of the ALUMALOK family!



**Specifications:** Load rated for 500 lbs. (227 Kg) UDL ■ Safety factor of 7-1 minimum ■ Solid CNC machined aluminum construction ■ Hardened STEEL grip arms ■ Single 1/2"-13 TPI threaded attachment points ■ Two 5/8" shackle points for dead hanging ■ Made in the U.S.A. ■ Color: extruded aluminum silver finish ■ Weight: 2.04Kgs/4.5Lbs ■ Size: 6"x4.25"x2"

The Aluma-Lok is designed to clamp to most airwall tracks with a slot opening of 1/2" to 1-1/2". The airwall track is captured between the body of the Aluma-Lok and the two hardened steel gripping arms. This operation is accomplished via the steel thumb knobs and an optional allen wrench, minimizing the number of tools required, and eliminating the possibility of damaging the airwall track by over tightening. This is the only product endorsed for use in Marriott hotels worldwide. Made in the U.S.A.

**Specifications:** Load Rated: 750 UDL Working Load Rating ■ Safety factor of 7-1 minimum ■ Mounts to airwall tracks with an opening from 1/2" to 1-1/2" ■ Attachment points: Three 1/2" Bolt (13TPI) locations, two 5/8" Shackle holes, one 2" diameter clamp area ■ Color: extruded aluminum silver finish ■ Weight: 4.10Kgs/9Lbs ■ Size: 10"x8.5"x2"

**CLAMP-AIRWALLMINI**

AlumaMini provides for safe and quick cable pick points across an airwall. Load rated at 250 lbs (113 kgs) UDL this is the mini of airwall track rigging.



**Specifications:** Load rated for 250 lbs. (113 Kg) UDL ■ Safety factor of 7-1 minimum ■ Solid CNC machined aluminum construction ■ Hardened STEEL grip arm ■ Two 1/2" shackle bolt attachment points ■ Made in the U.S.A. ■ Color: extruded aluminum silver finish ■ Weight: 1Kgs/2.2Lbs ■ Size: 3"x4.25"x2"

Specifications are subject to change without notice.



# CLAMPS

## CLAMP-O



Easily and safely attaches to round truss, pipe or light stand crossbars. Provides very solid grip without scratching or marring stand surface. Fits 1-1/2" and 2" tubes. Weight: .23Kg/.5Lbs

## MEGA CLAMP

### CLAMP-MEGA/B

Black - Anodized

### CLAMP-MEGA/P

Polished - Clear Anodized



Professional high quality pipe clamp. Aluminum with strength of steel. Very lightweight. For pipe sizes ranging from 1" to 2" maximum. With 1/2" x 3" square head set bolt, 1/2" grade 5 hex head mounting bolt, and nickel plated steel Belleville spring washer for pan tensioning device. Weight 13.8oz. Safe vertical working load: 272Kgs/600Lbs. Size: 4"x6.3"x1"

### CLAMP-MINI/X\*



The professional mini clamp in polished aluminum (also available in black). For pipe sizes ranging from 1/2" to 2" maximum. Mounting bolt is 3/8". Capacity: 20Kg/ 44Lbs ■ Weight: 172.94g/ 6.1oz

\*X specifies finish: **B**-black, **P**-polished silver

### CLAMP-4542

Heavy duty steel pipe clamp with 3/8" mounting bolt. Pipe diameter: 1" to 2.25" maximum. Weighs: 2Lbs



### CLAMP-HDQ



Heavy duty quick release clamp. Special mechanism allows clamp to release from fixture. For pipes sizes from 1 to 2 inches. Weight: .45Kg/ 1Lbs

### CLAMP-STEEL 1



Heavy duty steel pipe clamp with 1/2" mounting bolt. Pipe diameter: 1" to 2" ■ Weight: .94Kgs/2.07Lbs ■ Size: 6.75"x4.25"x2.13"

## MEGA-CLAW

### CLAMP-CLAW/P



The Mega-Claw was designed for intelligent lighting. The instant it is put over the pipe, the weight of the fixture is supported. Safe Vertical Working Load: 500kg/ 1,100 lbs ■ Size: 6"x4.375"x2" ■ Weight .9kg/2lbs

## MINI-CLAW

### CLAMP-CLAWMIN/P



The Mini-Claw clamp is made of a lightweight high strength aluminum alloy. A quick locking jaw allows it to hold the weight of the fixture while fastening. The large aluminum T-handle with captive thrust washer makes it easy to tighten down firmly. Fits on outer diameter pipes from 1.66" to 2". Does not dent truss tubing. Maximum load capacity of 45Kg/100Lbs. Size: 5"x4.25"x2" ■ Weight .39Kg/ .86Lbs

## CLAMP-C



Medium duty C-clamp. The most economical clamp available. Attaches to 1-2 inch pipe. Ideal for small effects, pin-spots and par-cans. Weight: .45Kg/ 1Lbs



**CLAMP-TOOL** For professional pipe clamps, one tool can adjust 3 types of clamp bolts. Made of aluminum and only weighs 1.4 ounces. Size: 2-3/4" long.



### CLAMP-4602

Crocodile grip clamp.



### CLAMP-MICRO/B

Black

### CLAMP-MICRO/P

Polished Silver

Perfect for small fixtures like Par16s.

■ Fits pipe sizes from 3/8" to 1"

■ Capacity: 125Lbs

■ Size: 4"x2.5"x.63"

■ Weight: 0.1Kgs/.22Lbs



### CLAMP-0055



Cube adapter for yoke mounting to tripod stands with Baby 5/8"

■ Bolt: 3/8" diameter

■ Size: 2.5"x2.25"x1.5"

■ Weight: .15Kgs/0.33Lbs



## CLAMP-FASTLOCK

The "Fast-Lock" clamp is manufactured of aluminum and is designed to insure secure hanging of Giotto fixtures from truss bars or scaffolding with a pipe diameter of between 1.5 and 2 inches.

There are 8 slots on the underside of Giotto fixtures for quick fitting the clamps, which may be positioned horizontally, vertically or at an angle of 15°, according to the fixture base.

## CHEESEBOROUGH

Cheeseborough coupling clamps are a great way of rigging pipes and truss. Made of polished aluminum. Does not dent truss. Fastens onto 1.9" to 2" outer diameter pipes.

### CLAMP-CBHALF/LP

Low profile single half coupler with 3/8" bolt mount.

■ Size: 4"x3.3"x1.2"

■ Load Capacity: 200 Lbs

■ Weight: 0.15Kgs/0.34Lbs



### CLAMP-CBHALF/N

Narrow width single half coupler with 3/8" bolt mount.

■ Size: 4.5"x5"x1.2"

■ Load Capacity: 650 Lbs

■ Weight: 0.35Kgs/0.8Lbs



### CLAMP-CBHALF

Single half cheeseborough coupler with 1/2" bolt mount.

■ Size: 5.5"x4.5"x2"

■ Load Capacity: 1100 Lbs

■ Weight: 0.57Kg/1.3Lbs



### CLAMP-CBSWIVEL

Two halves which swivel/turn freely to any angle needed.

■ Size: 7.5"x4.5"x2"

■ Load Capacity: 1100 Lbs

■ Weight: 1.07Kgs/2.4Lbs



### CLAMP-CBFIXED

Two half couplers which lock in parallel 180 degrees, or perpendicular 90 degrees.

■ Size: 7.5"x4.5"x2"

■ Load Capacity: 1100 Lbs

■ Weight: 1.07Kgs/2.4Lbs

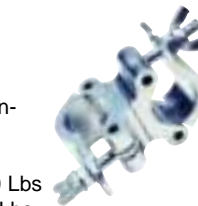

### CLAMP-CBRING

Single half coupler with a hook ring.

■ Size: 5.5"x5.5"x2"

■ Load Capacity: 1100 Lbs

■ Weight: .6Kgs/1.3Lbs



## TRUSS PICK POINTS

The Mega-Truss Pick is CNC machined from solid 1" x 6" 6061 T-6 aluminum billet. Two pockets cut into the Mega-Truss Pick have coupler style aluminum pivoting links, half inch swivel bolts, and our solid wing nuts to completely wrap around the truss tube to secure it.

The Mega-Truss Pick has one top and one bottom rigging hole for attaching the truss to a shackle, motor, or chain hook. The Mega-Truss Pick will suspend up to one ton of truss load, plus an additional one ton load suspended under the truss. The Mega-Truss Pick weighs less than 4 pounds for the 12" truss version. Other models are available for 16", 18", 20.5", 24", and 30" truss.

### CLAMP-TRP12

**Specifications:** 12" Truss pick ■ Safe Vertical Working Load - 1 ton truss / 2 ton total ■ Size: 1" thick x 6" tall x 13-3/8" long ■ Weight: 1.82Kgs/4Lbs ■ Color: Aluminum finish



Specifications are subject to change without notice.

## SANDBAGS

Sandbags for staging, theatrical and grip applications:

Our industrial sandbags are manufactured using a high performance denier polyester canvas and stitched to mil-spec standards, using heavy duty bonded polyester thread for structural integrity. The high strength handles are made of polypropylene strap webbing, and sewn on using a military cross stitch and box pattern to ensure a durable and reliable attachment. All seams are double rolled for extra strength and made to endure the stress of production use, indoors and outdoors. Available in 15, 25, and 35 pounds and feature a weight label tag for quick visual weight identification. Equipped with plastic moisture linings which help in maintaining the precision weighed sand dry. Empty zipper self-fill types or sand filled. Color: Black



Center and Butterfly Handle Sandbag  
Two-In-One!



Donut Sandbag

<b>SB-D40CDFB</b>	Sandbag Donut 40lb Dual Handle Filled
<b>SB-S15CBF</b>	Sandbag Saddle 15lb Center and Butterfly Handle Filled
<b>SB-S15CBZ</b>	Sandbag Saddle 15lb Center and Butterfly Handle Zippered Empty
<b>SB-S25CBF</b>	Sandbag Saddle 25lb Center and Butterfly Handle Filled
<b>SB-S25CBZ</b>	Sandbag Saddle 25lb Center and Butterfly Handle Zippered Empty
<b>SB-S35CBF</b>	Sandbag Saddle 35lb Center and Butterfly Handle Filled
<b>SB-S35CBZ</b>	Sandbag Saddle 35lb Center and Butterfly Handle Zippered Empty

## XLR CABLES

Male to female XLR cables for DMX data use. The 3-pin XLR cables may also be used as LO-Z microphone cables. **Specifications:** Flexible black PVC jacket ■ UL2696 ■ Individually packaged ■ Black XLR Connectors with gold contacts ■ Suitable for permanent install and production use.



Call for pricing on touring grade cables.

<b>CA-XLR3/1</b>	XLR 3-Pin Female to 3-Pin Male Cable - 1 foot
<b>CA-XLR3/5</b>	XLR 3-Pin Female to 3-Pin Male Cable - 5 feet
<b>CA-XLR3/10</b>	XLR 3-Pin Female to 3-Pin Male Cable - 10 feet
<b>CA-XLR3/25</b>	XLR 3-Pin Female to 3-Pin Male Cable - 25 feet
<b>CA-XLR3/50</b>	XLR 3-Pin Female to 3-Pin Male Cable - 50 feet
<b>CA-XLR3/100</b>	XLR 3-Pin Female to 3-Pin Male Cable - 100 feet

<b>CA-XLR5/1</b>	XLR 5-Pin Female to 5-Pin Male Cable - 1 foot
<b>CA-XLR5/5</b>	XLR 5-Pin Female to 5-Pin Male Cable - 5 feet
<b>CA-XLR5/10</b>	XLR 5-Pin Female to 5-Pin Male Cable - 10 feet
<b>CA-XLR5/25</b>	XLR 5-Pin Female to 5-Pin Male Cable - 25 feet
<b>CA-XLR5/50</b>	XLR 5-Pin Female to 5-Pin Male Cable - 50 feet
<b>CA-XLR5/100</b>	XLR 5-Pin Female to 5-Pin Male Cable - 100 feet

## POWER CABLES

### PC-Series

Heavy duty power cables are available in standard and custom configurations.



Standard Socapex 19-pin male to female in multi-conductor cable 12/19 and 12/14 exist in 25, 50, 75, and 100 foot lengths. Provides six circuits of power. Our cables are labeled with the length for easy identification and include 6 inches of heat shrink for company name placement.

<b>PC-BI-S-06-EDISON</b>	Break-In Socapex, 19 Pin F to Edison M,6', 12/3, Black
<b>PC-BI-S-06-L620</b>	Break-In Socapex, 19 Pin F to L620 M, 6', 12/3, Black
<b>PC-BI-S-06-S3PIN</b>	Break-In Socapex, 19 Pin F to S3Pin M, 6', 12/3, Black
<b>PC-BO-S-06-EDISON</b>	Break-Out Socapex, 19 Pin M to Edison F,6', 12/3, Black
<b>PC-BO-S-06-L620</b>	Break-Out Socapex, 19 Pin M to L620 F, 6', 12/3, Black
<b>PC-BI-S-06-S3PIN</b>	Break-Out Socapex, 19 Pin M to S3Pin F, 6', 12/3, Black

### Motor Control & Power Cables

<b>PC-147S7PIN-025</b>	14/7, Male/Female Socapex 7 Pin, 25', Black
<b>PC-147S7PIN-050</b>	14/7, Male/Female Socapex 7 Pin, 50', Black
<b>PC-147S7PIN-075</b>	14/7, Male/Female Socapex 7 Pin, 75', Black
<b>PC-147S7PIN-100</b>	14/7, Male/Female Socapex 7 Pin, 100', Black

### Power Multi-Cables

<b>PC-12/14S-025</b>	Socapex Male to Female 19 pin, 12/14 Black, 25 feet
<b>PC-12/14S-050</b>	Socapex Male to Female 19 pin, 12/14 Black, 50 feet
<b>PC-12/14S-075</b>	Socapex Male to Female 19 pin, 12/14 Black, 75 feet
<b>PC-12/14S-100</b>	Socapex Male to Female 19 pin, 12/14 Black, 100 feet
<b>PC-12/3SO-250</b>	12/3SO Power Cable, 12AWGx3, Black, 250 feet

## XLR CONNECTORS

XLR connectors are available in a variety of configurations and pin numbers. All connectors have nickel plating for reliable connections. The adapters now come in black body finish. 3-pin XLRs are commonly used in the audio industry and in the lighting industry for DMX data connection. 5-pin XLRs are also very popular for lighting industry data connections. 5-pin plugs are the "true" USITT DMX512 lighting standard, although many manufacturers have elected to use 3-pin for flexibility and availability.

When converting from 3 to 5 pin, it is important that Pin 1 remains the shield/ground. Pins 2 and 3 both remain the same in both connectors. In the 5-pin connector, pins 4 & 5 remain unused when converting. Our handy adapters provide proper conversions.

**CO-XLR3MTO5F** Adapter for DMX lighting applications, to go from 3-pin male to 5-pin female

**CO-XLR5MTO3F** Adapter for DMX lighting applications, to go from 5-pin male to 3-pin female

**CO-XLRTERM3** Three pin DMX terminator-XLR male  
**CO-XLRTERM5** Five pin DMX terminator-XLR male



**CO-XLR3F** In-line 3-Pin Female XLR  
**CO-XLR3FP** Panel mount 3-Pin Female XLR  
**CO-XLR3M** In-line 3-Pin Male XLR  
**CO-XLR3MP** Panel mount 3-Pin Male XLR



**CO-XLR3FP**  
XLR 3-Pin Panel Mount - Female

**CO-XLR5F** In-line 5-Pin Female XLR  
**CO-XLR5FP** Panel mount 5-Pin Female XLR  
**CO-XLR5M** In-line 5-Pin Male XLR  
**CO-XLR5MP** Panel mount 5-Pin Male XLR



**CO-XLR5MP**  
XLR 5-Pin Panel Mount - Male



**CO-XLR5MTO3F**  
XLR Adapter 5 Pin Male to 3 Pin Female



**CO-XLR5F**  
XLR 5-Pin Connector-Female



**CO-XLR3MTO5F**  
XLR Adapter 3 Pin Male to 5 Pin-Female



**CO-XLR3M**  
XLR 3-Pin Connector-Male

Specifications are subject to change without notice.





## POWER CONNECTORS









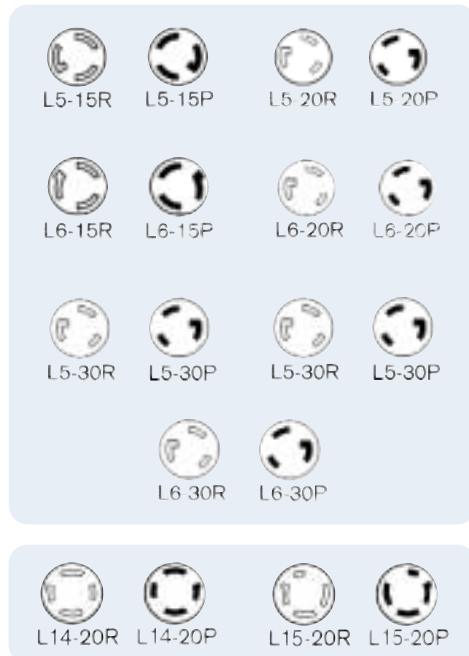

Industrial grade construction and an all black ribbed nylon housing provides excellent impact resistance and hides well on stages and in theaters. The connector housings are beveled to prevent the connector from catching on stairs or equipment. Oversized mechanical clamp traps cord for exceedingly strong grip, eliminating strain on terminals. These plugs are quick and easy to install with wire entrance holes that are close together. Terminal screws are color coded for safety and provided in the "open" position for quick wire install. All devices are UL listed and CSA certified.

### TWIST LOCKING DEVICES

<b>CO-L515F</b>	Twistlock 4729 15a 125v Female Receptacle Black	NEMA L5-15R
<b>CO-L515M</b>	Twistlock 4720 15a 125v Male Plug Black	NEMA L5-15P
<b>CO-L520F</b>	Twistlock 2313 20a 125v Female Receptacle Black	NEMA L5-20R
<b>CO-L520M</b>	Twistlock 2311 20a 125v Male Plug Black	NEMA L5-20P
<b>CO-L530F</b>	Twistlock 305CBL 2613 30a 125v Female Plug Black	NEMA L5-30R
<b>CO-L530M</b>	Twistlock 2613 30a 125v Male Plug Black	NEMA L5-30P
<b>CO-L615F</b>	Twistlock 4579 15a 250v Female Receptacle Black	NEMA L6-15R
<b>CO-L615M</b>	Twistlock 4570 15a 250v Male Plug Black	NEMA L6-15P
<b>CO-L620F</b>	Twistlock 2323 20a 250v Female Receptacle Black	NEMA L6-20R
<b>CO-L620M</b>	Twistlock 2321 20a 250v Male Plug Black	NEMA L6-20P
<b>CO-L630M</b>	Twistlock 2623 30a 250v Male Plug Black	NEMA L6-30P
<b>CO-L1420F</b>	Twistlock 2014C 2413 20a 125/250v 3 pole 4 wire Female	NEMA L14-20R
<b>CO-L1420M</b>	Twistlock 2014P 2411 20a 125/250v 3 pole 4 wire Male	NEMA L14-20P
<b>CO-L1520F</b>	Twistlock 2015C 2423C 20a 250v 3 pole 4 wire Female	NEMA L15-20R
<b>CO-L1520M</b>	Twistlock 2015P 2421P 20a 250v 3 pole 4 wire Male	NEMA L15-20P



### EDISON BLADE DEVICES

							
<b>CO-515F</b>	Standard Edison 5269 15a 125v Female Black	NEMA 5-15R					
<b>CO-515M</b>	Standard Edison 5266 15a 125v Male Plug Black	NEMA 5-15P					
<b>CO-520F</b>	Edison 5369 20a 125v Female Receptacle Black	NEMA 5-20R					
<b>CO-520M</b>	Edison 5366 20a 125v Male Plug Black	NEMA 5-20P					
<b>CO-615F</b>	5669 15a 250v Female Connector Receptacle	NEMA 6-15R					
<b>CO-615M</b>	5666 15a 250v Male Connector Plug	NEMA 6-15P					
<b>CO-620F</b>	5469 20a 250v Female Connector Receptacle	NEMA 6-20R					
<b>CO-620M</b>	5466 20a 250v Male Connector Plug	NEMA 6-20P					

#### CO-POWERCONM

Locking 3 pole power in connector. Fast and easy locking system with a high current capacity of 20 Amps. Neutrik NAC3FCA, blue color body. Power: 250v AC max



### POWER SPLIT ADAPTERS

Adapters are ready to wire devices



**PC-PSY12/3-24:** 12/3 SO Cable 24"  
**PC-PSY12/3-36:** 12/3 SO Cable 36"

**PC-PSW12/3-24:** 12/3 SO Cable 24"  
**PC-PSW12/3-36:** 12/3 SO Cable 36"

### STAGE PIN DEVICES

Highest quality, Bates 20 Amp stagepin plugs available.

<b>CO-STAGE3FBK</b>	Stage 3 Pin Inline Female Black
<b>CO-STAGE3FCC</b>	Stage 3 Pin Inline Female Clear
<b>CO-STAGE3FPM</b>	Stage 3 Pin Female Panel Mount
<b>CO-STAGE3MBK</b>	Stage 3 Pin Inline Male Black
<b>CO-STAGE3MCC</b>	Stage 3 Pin Inline Male Clear

Also available in 60 and 100 amp versions.



## CAM TYPE DEVICES

**Cam-type** waterproof locks built for reliable service under all conditions with Advanced Devices signature integrity of design and quality construction, the new CLS Series is NEMA 3R and 4 rated for weather tight construction, CSA and CUS listed 400A/600V and meets 1999 NEC standards for locking connectors.

**CO-CLS2FXX** Cam #6-#2  
Connector Female

**CO-CLS2MXX** Cam #6-#2  
Connector Male

**CO-CLS40FXX** Cam 4/0 Connector Female

**CO-CLS40MXX** Cam 4/0 Connector Male

**CO-CLS40TO20** Cam Wire Reducer 4/0 to 2/0



## MINI CAMS

**CO-CLM2FXX** Mini Cam #8 - #2  
female connector

**CO-CLM2MXX** Mini Cam #8 - #2  
male connector



## PANEL MOUNT CAMS



**CO-CL40FRBXX** Panel Mount 2/0 - 4/0 Double Set Screw Female

**CO-CL40MRBXX** Panel Mount 2/0 - 4/0 Double Set Screw Male

**CO-CL40FRSBXX** Panel Mount 4/0 Stud Female

**CO-CL40MRSBXX** Panel Mount 4/0 Stud Male

## CAM ADAPTORS

**CO-CLCTTXX** Tapping T Male-Female-Female Cam

**CO-CLCPTXX** Parallel T Female-Male-Male Cam

**CO-CLCDMMXX** Coupling Turnaround Male-Male Cam

**CO-CLCDFXX** Coupling Turnaround Female-Female Cam

**CO-CLCA3FSTA** Cam Soft 3-way

**CO-CLCA3FA** Cam 3-way

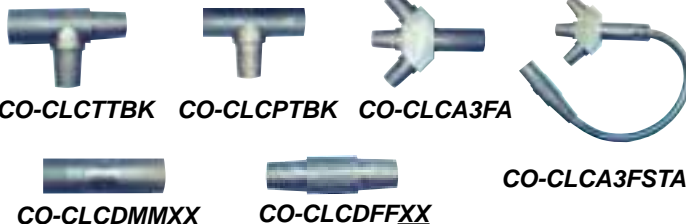

**XX** in product code represents color: **BK**-Black; **BL**-Blue; **GR**-Green; **RD**-Red; **WH**-White

## SOCAPEX



**CO-SOCA-IF** Socapex 19 pin  
Inline Female Connector  
SLGFFDR419AR - All Black  
■ Weight: 0.23Kgs/0.5Lbs ■  
Size: 2.5"x2" dia



**CO-SOCA-IM** Socapex 19  
pin Inline Male Connector  
SLGFMDR419AR - All Black  
■ Weight: 0.27Kgs/0.6Lbs ■  
Size: 3.5"x2.5" dia



**CO-SOCA-PF** Socapex 19 pin  
Panel Mount Female Connector  
SLGEF419AR - All Black ■  
Weight: 0.11Kgs/0.25Lbs ■  
Size: 2.19"x2.19"x1"

**CO-SOCA-PFT** Socapex 19  
pin Panel Mount Female  
Connector with 2' THHC cable  
tail, labeled

**CO-SOCA-PM** Socapex 19 pin  
Panel Mount Male Connector  
SLEME419AR - All Black

## ROPE LIGHTING

### RL-ROPE LIGHTING

Solid PVC flexible rope lighting is used for thousands of applications ranging from stage outlining, architectural wall high lighting, decorative motifs, to safety lighting for staircases. Long life span: average 35,000 hours ■ High pressure/crush resistant PVC ■ Temperature resistant 40°C to 105°C ■ Low power consumption ■ Various voltages: 12v, 24v, 120v, 230v ■ U.L. listed.

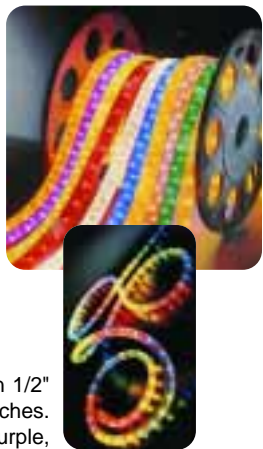

**RL-IF65** Series: Standard round is offered in 1/2" and 3/8" diameters. Can be cut every 18 inches. Colors: Clear, Blue, Green, Orange, Pink, Purple, Yellow, Red, White, Pearl Blue, Pearl Green, Pearl Yellow, Pearl Red, Fluorescent Green, Fluorescent Orange.

**RL-CF5** Series: 4 Channel multi-chasing round offered in 5/8" diameter. Can be cut every 6 feet. Colors: Clear/Clear, Clear with RGBY bulbs.

**RL-CF4** Series: 3 Channel multi-chasing round offered in 5/8" diameter. Can be cut every 5 feet. Colors: many combinations

**RL-CF65** Flex Rope Chasing 2 Channel 3 wire 1/2" diameter 120v 4' - SPEC COLOR

**RL-CF65AC1** Flex Rope Chasing 2 Channel 3 wire AC Power and Cord Connector

**RL-CF65AC3** Flex Rope Chasing 2 Channel 3 wire Splice Connector

Options also available: in-line connectors, T-split and Y-split connectors, controllers, end caps, power cords, extensions, mounting clips and clear mounting track in 3/8", 1/2" and 5/8" widths.

## LED ROPE LIGHTING

The next generation of rope lighting now features LEDs as the light source. With LEDs rope lighting has become extremely robust, has a longer life span (100,000 average hours), and has become more energy efficient thus cost saving. In addition, almost no heat dissipation is produced further adding to the many benefits.

**Specifications:** operates on 120v, 2 wire ■ 1/2" Diameter Clear ■ 1" LED spacing ■ Available in 5 vibrant colors ■ Cutting lengths vary by color ■ Spool size of 150-153 feet

Blue, Green, White - Cutting size 3 feet, maximum run 600 feet

**RL-IFL65BL** Blue 1/2" 120v LED Rope

**RL-IFL65GR** Green 1/2" 120v LED Rope

**RL-IFL65WH** White 1/2" 120v LED Rope

Red, Yellow - Cutting size 4.5 feet, maximum run 900 feet

**RL-IFL65RD** Red 1/2" 120v LED Rope, cutting size 4.5 feet

**RL-IFL65YE** Yellow 1/2" 120v LED Rope, cutting size 4.5 feet

**RL-IFLAF106** AC power cord and connector with rectifier





# GOBO PATTERNS

Metal, glass and dichroic gobos in all sizes. Custom and standard patterns. Specify pattern, fixture and gobo size when ordering. Lead times and camera ready art are required.

Code:	Description
<b>GOBO-CRUSHDIC</b>	Crushed Dichroic
<b>GOBO-CRUSHDICE</b>	Enhanced Crushed Dichroic
<b>Glass Gobos</b>	
<b>GOBO-GLABW1CUS</b>	Glass B&W or 1 Color Custom Original
<b>GOBO-GLABW1DUP</b>	Glass B&W or 1 Color Custom Duplicate
<b>GOBO-GLABW1STD</b>	Glass B&W Standard Super Resolution
<b>GOBO-GLA2CCUS</b>	Glass 2 Color Custom 1st Original
<b>GOBO-GLA2CDUP</b>	Glass 2 Color Custom Duplicate
<b>GOBO-GLA2CSTD</b>	Glass 2 Color Standard
<b>GOBO-GLACSCUS</b>	Glass Full Color Scenic Custom Original
<b>GOBO-GLACSDUP</b>	Glass Full Color Scenic Duplicate
<b>GOBO-GLACSTD</b>	Glass Color Scenic Standard
<b>Metal Gobos</b>	
<b>GOBO-METCUS1ST</b>	Custom Original Metal
<b>GOBO-METCUSDUP</b>	Custom Duplicate Metal
<b>GOBO-METSTD1ST</b>	Standard Pattern Metal 1st
<b>GOBO-METSTDUP</b>	Standard Pattern Metal Duplicate
<b>Gobo Holders</b>	
<b>GOBO-HOLDGS4B</b>	Gobo Holder Source 4 Glass Size B
<b>GOBO-HOLDM360Q</b>	Gobo Holder 360Q Metal Size 2-3/4"
<b>GOBO-HOLDMGS4B</b>	Gobo Holder Source 4 Metal & Glass Size B
<b>GOBO-HOLDMLEO</b>	Gobo Holder NSI LEO Metal, Size 3-1/8"
<b>GOBO-HOLDMS4B</b>	Gobo Holder Source 4 Metal Size B

# GOBO PROJECTORS

## TH-GOBO1B

Our most compact and lightweight single gobo pattern projector. Very effective when used in multiples. Great for store displays, night clubs, tradeshow and applications where a company logo or brand name may need to be projected. Uses 50mm diameter gobos. Manual turn focus lens. Custom gobos may be ordered.



**Specifications:** FNV MR16 50w 12v Lamp ■ Metal or plastic slide type gobo ■ Gobo size: 50mm diameter, image area 27mm ■ Forced fan cooling ■ Color: Blue ■ Size: 11.1"x3.76"x3.93" ■ Weight: 1.5Kgs/3.3Lbs ■ Power: 120v-50/60Hz ■ Current Draw: 0.7 Amps

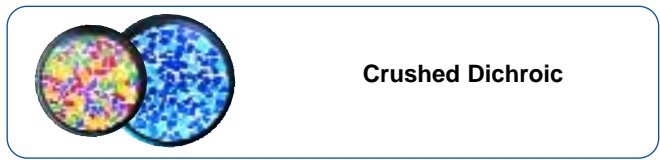
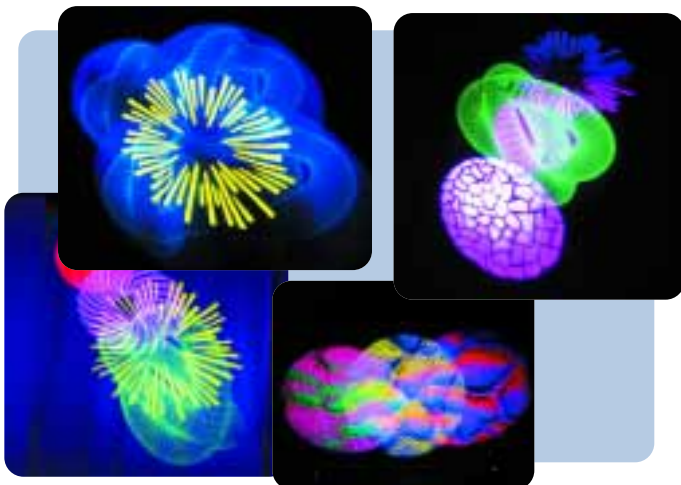

Crushed Dichroic

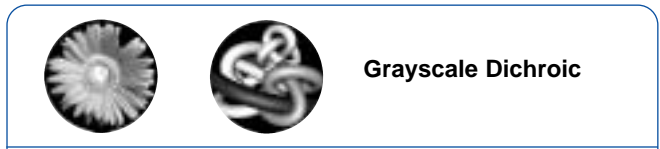

Grayscale Dichroic



One Color Dichroic

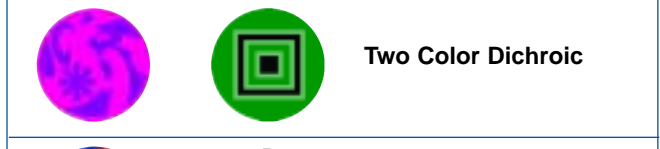

Two Color Dichroic

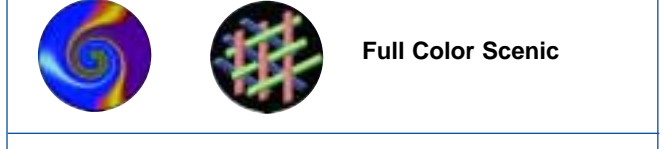

Full Color Scenic

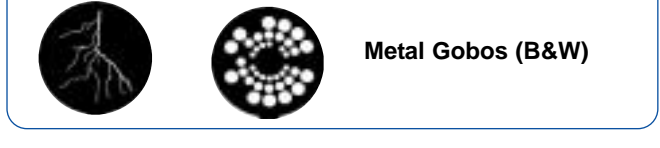

Metal Gobos (B&W)



Gobos Holders

## ROTOGOBO 250

### EL-ROTOGOBO250

The RotoGobo 250 is a must for displays, exhibitions, shop windows, nightclubs and pubs. It projects gobo patterns with or without color, which can rotate and change automatically or via DMX. Using the dip switches, stand alone operation allows setting of interval gobo change time, rotating speed, and rotation direction in various increments without the need for a controller. With a DMX controller, channel one controls which gobo is selected, and channel 2 chooses the direction and speed of rotation. All gobos are interchangeable. Custom gobos may be ordered for this fixture. Focusable using manual turn Lens.



**Specifications:** ELC 250w 24v Lamp ■ 7 interchangeable gobos included ■ Uses glass or metal gobos ■ Gobo size: 25mm diameter, image area 18mm ■ DMX control via 2 channels ■ 3-Pin XLR input for DMX ■ Color: Black ■ Size: 11.1"x8.7"x6.3" ■ Weight: 6.4Kgs/14.1Lbs ■ Power: 120v-50/60Hz ■ Current Draw: 3.15 Amps

Specifications are subject to change without notice.



# UltraGel

■ Large Color Selection ■ Surface Coated on Both Sides ■ Wide Range of Filters  
 ■ Long Lasting ■ 21" x 24" Sheets ■ High Color Stability ■ Direct Number Color Cross ■ Flame Retardant ■ Batch to Batch Uniformity

- |                           |                           |                              |                                     |                               |                               |
|---------------------------|---------------------------|------------------------------|-------------------------------------|-------------------------------|-------------------------------|
| ___ 002 Rose Pink         | ___ 101 Yellow            | ___ 156 Chocolate            | ___ 211 .9 Neutral Density          | ___ 313 Special Light Amber   | ___ 711 Cold Blue             |
| ___ 003 Lavender Tint     | ___ 102 Light Amber       | ___ 157 Pink                 | ___ 212 L.C.T. Yellow               | ___ 315 Special Golden Amber  | ___ 712 Bedford Blue          |
| ___ 004 Med Bastard Amber | ___ 103 Straw             | ___ 158 Deep Orange          | ___ 213 White Flame Green           | ___ 317 Dark Amber            | ___ 713 J. Winter Blue        |
| ___ 007 Pale Yellow       | ___ 104 Deep Amber        | ___ 159 No Color Straw       | ___ 214 Full Tuff Spun Weave        | ___ 321 Light Red             | ___ 714 Elysian Blue          |
| ___ 008 Dark Salmon       | ___ 105 Orange            | ___ 161 Slate Blue           | ___ 215 1/2 Tuff Spun Weave         | ___ 322 Soft Green            | ___ 715 Cabana Blue Get       |
| ___ 009 Pale Amber Gold   | ___ 106 Primary Red       | ___ 162 Bastard Amber        | ___ 216 White Diffusion             | ___ 323 Jade                  | ___ 716 Mikkel Blue           |
| ___ 010 Medium Yellow     | ___ 107 Light Rose        | ___ 164 Flame Red            | ___ 217 Blue Diffusion              | ___ 325 Mallard Green         | ___ 717 Shanklin Frost        |
| ___ 013 Straw Tint        | ___ 108 English Rose      | ___ 165 Daylight Blue        | ___ 218 1/8 C.T. Blue               | ___ 327 Forest Green          | ___ 718 Half Shanklin Frost   |
| ___ 015 Deep Straw        | ___ 109 Light Salmon      | ___ 166 Pale Red             | ___ 219 Fluorescent Green           | ___ 328 Follies Pink          | ___ 719 Color Wash Blue       |
| ___ 017 Surprise Peach    | ___ 110 Middle Rose       | ___ 169 Lilac Tint           | ___ 220 White Frost                 | ___ 332 Rose Pink             | ___ 720 Durham Daylight Frost |
| ___ 019 Fire              | ___ 111 Dark Pink         | ___ 170 Deep Lavender        | ___ 221 Blue Frost                  | ___ 339 Rose Purple           | ___ 721 Berry Blue            |
| ___ 020 Medium Amber      | ___ 113 Magenta           | ___ 172 Lagoon Blue          | ___ 223 1/8 C.T. Orange             | ___ 340 Surprise Lavender     | ___ 722 Bray Blue             |
| ___ 021 Gold Amber        | ___ 115 Peacock Blue      | ___ 174 Dark Steel Blue      | ___ 224 Daylight Blue Frost         | ___ 341 Plum                  | ___ 724 Ocean Blue            |
| ___ 022 Dark Amber        | ___ 116 Medium Blue Green | ___ 176 Loving Amber         | ___ 225 N.D. Frost                  | ___ 342 Special Lavender      | ___ 725 Old Steel Blue        |
| ___ 024 Scarlet           | ___ 117 Steel Blue        | ___ 179 Chrome Orange        | ___ 226 U.V.                        | ___ 343 Medium Lavender       | ___ 728 Steel Green           |
| ___ 025 Sunset Red        | ___ 118 Light Blue        | ___ 180 Dark Lavender        | ___ 228 Brushed Silk                | ___ 344 Violet                | ___ 729 Scuba Blue            |
| ___ 026 Bright Red        | ___ 119 Dark Blue         | ___ 181 Congo Blue           | ___ 229 Quarter Tough Spun          | ___ 345 Fuchsia Pink          | ___ 730 Liberty Green         |
| ___ 027 Medium Red        | ___ 120 Deep Blue         | ___ 182 Light Red            | ___ 230 Super Correction LCT Yellow | ___ 349 Pale Blue             | ___ 735 Velvet Green          |
| ___ 029 Plasa Red         | ___ 121 Evergreen         | ___ 183 Moonlight Blue       | ___ 232 Super White Flame           | ___ 350 No Color Blue         | ___ 738 Jas Green             |
| ___ 033 No Color Pink     | ___ 122 Fern Green        | ___ 184 Cosmetic Peach       | ___ 236 H.M.I. To Tungsten          | ___ 352 Glacier Blue          | ___ 746 Brown                 |
| ___ 035 Light Pink        | ___ 124 Dark Green        | ___ 185 Cosmetic Burgundy    | ___ 237 C.I.D. To Tungsten          | ___ 353 Lighter Blue          | ___ 748 Seedy Pink            |
| ___ 036 Medium Pink       | ___ 126 Mauve             | ___ 186 Cosmetic Silver Rose | ___ 238 C.S.I. To Tungsten          | ___ 354 Special Steel Blue    | ___ 750 Durham Frost          |
| ___ 039 Pink Carnation    | ___ 127 Smoky Pink        | ___ 187 Cosmetic Rouge       | ___ 241 Fluorescent 5700K           | ___ 357 Special Medium Blue   | ___ 763 Wheat                 |
| ___ 046 Dark Magenta      | ___ 128 Bright Pink       | ___ 188 Cosmetic Highlight   | ___ 242 Fluorescent 4300K           | ___ 360 Bright Blue           | ___ 764 Sun Color Straw       |
| ___ 048 Rose Purple       | ___ 129 Heavy Frost       | ___ 189 Cosmetic Silver Moss | ___ 243 Fluorescent 3600K           | ___ 361 Surprise Blue         | ___ 765 Ultra Yellow          |
| ___ 052 Light Lavender    | ___ 130 Clear             | ___ 190 Cosmetic Emerald     | ___ 244 Plus Green                  | ___ 363 Special Medium Blue   | ___ 767 Oklahoma Yellow       |
| ___ 053 Pale Lavender     | ___ 131 Marine Blue       | ___ 191 Cosmetic Aqua Blue   | ___ 245 1/2 Plus Green              | ___ 366 Cornflower            | ___ 774 Soft Amber Key 1      |
| ___ 058 Lavender          | ___ 132 Medium Blue       | ___ 192 Flesh Pink           | ___ 246 1/4 Plus Green              | ___ 371 Light Green           | ___ 775 Soft Amber Key 2      |
| ___ 061 Mist Blue         | ___ 134 Golden Amber      | ___ 193 Rosy Amber           | ___ 247 Minus Green                 | ___ 378 Yellow Green          | ___ 776 Nectarine             |
| ___ 063 Pale Blue         | ___ 135 Deep Golden Amber | ___ 194 Surprise Pink        | ___ 248 1/2 Minus Green             | ___ 380 Golden Amber          | ___ 777 Rust                  |
| ___ 068 Sky Blue          | ___ 136 Pale Lavender     | ___ 195 Zenith Blue          | ___ 249 1/4 Minus Green             | ___ 381 Rose Purple           | ___ 778 Millennium Gold       |
| ___ 071 Tokyo Blue        | ___ 137 Special Lavender  | ___ 196 True Blue            | ___ 250 1/2 White Diffusion         | ___ 382 Medium Purple         | ___ 779 Bastard Red           |
| ___ 075 Evening Blue      | ___ 138 Pale Green        | ___ 197 Alice Blue           | ___ 251 1/4 White Diffusion         | ___ 383 Light Green Blue      | ___ 781 Terry Red             |
| ___ 079 Just Blue         | ___ 139 Primary Green     | ___ 198 Palace Blue          | ___ 252 1/8 White Diffusion         | ___ 384 Sky Blue              | ___ 789 Blood Red             |
| ___ 085 Deeper Blue       | ___ 140 Summer Blue       | ___ 200 Double C.T. Blue     | ___ 253 Ultra-Frost                 | ___ 385 Deeper Blue           | ___ 790 Moroccan Pink         |
| ___ 088 Lime Green        | ___ 141 Bright Blue       | ___ 201 Full C.T. Blue       | ___ 255 Hollywood Frost             | ___ 386 Dark Bastard Amber    | ___ 791 Moroccan Frost        |
| ___ 089 Moss Green        | ___ 142 Pale Violet       | ___ 202 1/2 C.T. Blue        | ___ 256 Half Light Frost            | ___ 410 Opal Frost            | ___ 793 Vanity Fair           |
| ___ 090 Dark Yellow Green | ___ 143 Pale Navy Blue    | ___ 203 1/4 C.T. Blue        | ___ 278 1/8 + Green                 | ___ 416 3/4 White Diffusion   | ___ 794 Pretty 'N Pink        |
| ___ 100 Spring Yellow     | ___ 144 No Color Blue     | ___ 204 Full C. T. Orange    | ___ 279 1/8 Minus Green             | ___ 441 Full C.T. Straw       | ___ 795 Magical Magenta       |
|                           | ___ 147 Apricot           | ___ 205 1/2 C.T. Orange      | ___ 280 Black Aluminum Wrap         | ___ 442 Half C.T. Straw       | ___ 797 Deep Purple           |
|                           | ___ 148 Bright Rose       | ___ 206 1/4 C.T. Orange      | ___ 281 3/4 C.T. Blue               | ___ 443 Quarter C.T. Straw    | ___ 798 Chrysalis Pink        |
|                           | ___ 151 Gold Tint         | ___ 207 C.T. Orange + .3ND   | ___ 285 3/4 C.T. Orange             | ___ 444 Eighth C.T. Straw     | ___ F.1 Frost F.1             |
|                           | ___ 152 Pale Gold         | ___ 208 C.T. Orange + .6ND   | ___ 298 .15 ND                      | ___ 450 3/8 White Diffusion   | ___ F.2 Frost F.2             |
|                           | ___ 153 Pale Salmon       | ___ 209 .3 Neutral Density   | ___ 299 1.2 ND                      | ___ 452 1/16 White Diffusion  | ___ F.3 Frost F.3             |
|                           | ___ 154 Pale Rose         | ___ 210 .6 Neutral Density   | ___ 303 Pale Gold                   | ___ 702 Special Pale Lavender | ___ SWATCHBOOK                |
|                           |                           |                              | ___ 306 Medium Lemon                | ___ 704 Lily                  |                               |
|                           |                           |                              | ___ 308 Medium Straw                | ___ 705 Lily Frost            |                               |
|                           |                           |                              | ___ 309 Special Straw               | ___ 707 Ultimate Violet       |                               |
|                           |                           |                              | ___ 311 Flame                       | ___ 709 Electric Lilac        |                               |

Specifications are subject to change without notice.

## FLUORESCENT TUBE COVERS



### UG-TUBE#-##XX

Colored fluorescent tube guards come in several sizes, colors, and lengths. The tubes are constructed of polycarbonate UV stable resins with a wall thickness of .017". The resins incorporate the color as they are not dyed. Two black end caps are included with each tube. Sold in cases of 24.

**Sizes:** T8 diameter 1", T12 diameter 1.5" ■ **Lengths:** 48 inches, 96 inches ■ **Colors:** Clear, Amber, Blue, Green, Pink, Red, Purple, Yellow

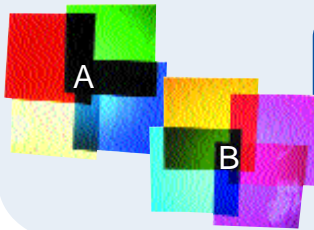

UltraGel is also available in pre-cut Color Pack selections:

**A:** Red, Yellow, Green, Blue.

**B:** Amber, Turquoise, Mauve, Pink

**Sizes:** Par 46: 7"x7" ■ Par 56: 8"x8" ■ Par 64: 9"x9"

## REPLACEMENT LAMPS AND BULBS



Techni-Lux stocks over 7,000 types of specialty and general lighting bulbs from low wattages to 20,000 watts. For all industries including theaters, night clubs, stage/studio, television, commercial, medical, video and cinema projection.

Bulb types include: Xenon ■ Metal Halide and High Intensity Discharge (HID) ■ Incandescent ■ Fluorescent ■ Compact Fluorescent ■ Halogen ■ Miniature ■ Sealed Beam/Par ■ Xenon Flash Strobe Tube ■ LED

Request our  
replacement  
lamp catalog!



# TAPES



Get the right tape for the right job. All specialty tapes have unique properties. Offered in various grades, sizes, and colors.



■ **Gaff tape** is engineered to be removed and not leave adhesive residue on cables or surfaces. It is normally cloth based and offered in many colors. Its non-reflective matte properties make it useful on dark stages, photo shoots and curtains. Water resistant, high temperature and weather resistant. ■ **Stage tape** is an economical version of gaff tape. It features the same adhesive backing and is matte finish. ■ **Console or board tape**, also known as artist tape, is used for labeling control boards. It features a special adhesive that will pull away from your audio or lighting console at time of removal. ■ **Duct tape** (commercial grade) is a vinyl based tape with a normal adhesive. ■ **Double sided tape** is mainly used on

convention and trade show floors for attaching carpet. Cloth type pulls off easier at removal time and leaves no residue. ■ **Electrical tape** U.L. listed electrical tape ■ **Glow tape** is used for stage marking and outlining. It phosphoresces after 30 seconds of light exposure. Brightest for initial 30 minutes and remains visible in dark areas for up to 8 hours. ■ **Caution tape** features diagonal black and yellow lines to OSHA standards. Used on stage steps and to mark danger areas. Vinyl material with standard adhesive. ■ **Gel repair tape** Heat resistant clear tape to repair torn gels ■ **Paper tape** professional photo masking tape ■ **Black matte wrap** is used for covering and masking off light.

Specifications are subject to change without notice.

<b>Pro-Gaff Tape</b> <b>TAPE-GAFF12RD</b> Gaff/Spike 1/2"x50 yds Red <b>TAPE-GAFF12WH</b> Gaff/Spike 1/2"x50 yds White <b>TAPE-GAFF12YE</b> Gaff/Spike 1/2"x50 yds Yellow <b>TAPE-GAFF1BK</b> Gaff 1"x60 yds Black <b>TAPE-GAFF1WH</b> Gaff 1"x60 yds White <b>TAPE-GAFF2BK</b> Gaff 2"x60 yds Black <b>TAPE-GAFF2BR</b> Gaff 2"x60 yds Brown <b>TAPE-GAFF2RD</b> Gaff 2"x60 yds Red <b>TAPE-GAFF2GY</b> Gaff 2"x60 yds Gray <b>TAPE-GAFF2WH</b> Gaff 2"x60 yds White <b>TAPE-GAFF2EBL</b> Gaff 2"x60 yds Electric Blue <b>TAPE-GAFF2LB</b> Gaff 2"x60 yds Light Blue <b>TAPE-GAFF2TE</b> Gaff 2"x60 yds Teal <b>TAPE-GAFF2LG</b> Gaff 2"x60 yds Light Green <b>TAPE-GAFF2OL</b> Gaff 2"x60 yds Olive <b>TAPE-GAFF2FLGR</b> Gaff 2"x50 yds Fluor.Green <b>TAPE-GAFF2FLYE</b> Gaff 2"x50 yds Fluor.Yellow <b>TAPE-GAFF2FLOR</b> Gaff 2"x50 yds Fluor.Orange <b>TAPE-GAFF2FLPK</b> Gaff 2"x50 yds Fluor.Pink <b>TAPE-GAFF3BK</b> Gaff 3"x60 yds Black <b>TAPE-GAFF3GY</b> Gaff 3"x60 yds Gray <b>TAPE-GAFF3WH</b> Gaff 3"x60 yds White <b>TAPE-GAFF3BY</b> Gaff 3"x60 yds Burgundy <b>TAPE-GAFF3FLOR</b> Gaff 3"x50 yds Fluor.Orange <b>TAPE-GAFF4BK</b> Gaff 4"x60 yds Black <b>TAPE-GAFF4GY</b> Gaff 4"x60 yds Gray <b>TAPE-CABLEYE4</b> Cable Path Yellow 4"x30 yds		<b>Permacel Gaff</b> <b>TAPE-GAFF2BKP</b> P-665 Gaff 2"x60 yds Black <b>TAPE-GAFF2WHP</b> P-665 Gaff 2"x60 yds White <b>TAPE-GAFF2GRP</b> P-665 Gaff 2"x60 yds Green <b>Stage - Economy Gaff - matte finish</b> <b>TAPE-STAGE2BK</b> Stage 2"x60 yds Black <b>TAPE-STAGE4BK</b> Stage 4"x60 yds Black <b>Duct Tape</b> <b>TAPE-DUCT2BK</b> Duct 2"x60 yds Black <b>TAPE-DUCT2GY</b> Duct 2"x60 yds Gray/Silver <b>TAPE-DUCT2BY</b> Duct 2"x60 yds Burgundy <b>TAPE-DUCT2BR</b> Duct 2"x60 yds Brown <b>Console/Board Tape</b> <b>TAPE-BOARD12</b> Board 1/2"x60 yds White <b>TAPE-BOARD34</b> Board 3/4"x60 yds White <b>TAPE-BOARD1</b> Board 1"x60 yds White <b>Electrical Tape</b> <b>TAPE-ELEC34BK</b> Elec. U.L. 3/4x66 Ft Black <b>TAPE-ELEC34BL</b> Elec. U.L. 3/4x66 Ft Blue <b>TAPE-ELEC34BR</b> Elec. U.L. 3/4x66 Ft Brown <b>TAPE-ELEC34GR</b> Elec. U.L. 3/4x66 Ft Green <b>TAPE-ELEC34GY</b> Elec. U.L. 3/4x66 Ft Gray <b>TAPE-ELEC34OR</b> Elec. U.L. 3/4x66 Ft Orange <b>TAPE-ELEC34PU</b> Elec. U.L. 3/4x66 Ft Purple <b>TAPE-ELEC34RD</b> Elec. U.L. 3/4x66 Ft Red <b>TAPE-ELEC34WH</b> Elec. U.L. 3/4x66 Ft White <b>TAPE-ELEC34YE</b> Elec. U.L. 3/4x66 Ft Yellow		<b>Carpet Tape - Double Sided (two sided)</b> <b>TAPE-DOUBLE1</b> Double 1"x30 yds <b>TAPE-DOUBLE2</b> Double 2"x30 yds <b>Glow Tape</b> <b>TAPE-GLOW1-10</b> Glow 1"x10 yds <b>TAPE-GLOW12-10</b> Glow 1/2"x10 yds <b>TAPE-GLOW2-10</b> Glow 2"x10 yds <b>Caution Tape</b> <b>TAPE-STRIPE2YB</b> 2"x30 yds Stripe Yellow/Black <b>TAPE-STRIPE3YB</b> 3"x18 yds Stripe Yellow/Black <b>Gel Repair Tape-Clear</b> <b>TAPE-JLAR1</b> Gel Repair Tape 1"x72 yds <b>TAPE-JLAR2</b> Gel Repair Tape 2"x72 yds <b>Paper Tape</b> <b>TAPE-PAPER1BK</b> Paper 1"x60 yds Black <b>TAPE-PAPER1WH</b> Paper 1"x60 yds White <b>TAPE-PAPER2BK</b> Paper 2"x60 yds Black <b>Black Matte Wrap - No adhesive</b> <b>TAPE-WRAPBLK12</b> Matte wrap 12"x50' Black <b>TAPE-WRAPBLK24</b> Matte wrap 24"x25' Black	
---	--	--	--	--	--



Electrical tape available in ten colors!

## DURACELL PROCELL BATTERIES



Industry professionals prefer and only use PROCELL. If your show or event depends on a reliable and long lasting battery then PROCELL is the clear choice for a consistent performance. Sold in inner packs, packs and cases.

Code:	Battery Description	Pack Sizes
<b>BAT-123PRO</b>	3v Lithium 123A	6 / 24
<b>BAT-4ACOP</b>	AAAA 1.5v Copper Top	2 / 12 / 48
<b>BAT-6VCOP</b>	6v Copper 908 Square Lantern Type w/Spring Terminals	6
<b>BAT-9VPRO</b>	9V Pro-Cell	12 / 72 / 288
<b>BAT-AAAPRO</b>	AAA 1.5v Pro-Cell	4 / 24 / 72
<b>BAT-AAPRO</b>	AA 1.5v Pro-Cell	4 / 24 / 144 / 576
<b>BAT-CPRO</b>	C 1.5v Pro-Cell	12 / 72
<b>BAT-DPRO</b>	D 1.5v Pro-Cell	12 / 72

## TIE WRAPS

Cable tie wraps made of Nylon 66. Also known as plastic zip ties. UL Approved ■ Color: Black or Natural



Code	Description	Tensile Strength	Pack Size
<b>TIEWRAP04B</b>	4" Black	18 Lbs	1000
<b>TIEWRAP06B</b>	6" Black	40 Lbs	1000
<b>TIEWRAP08B</b>	8" Black	50 Lbs	1000
<b>TIEWRAP11B</b>	11" Black	50 Lbs	100
<b>TIEWRAP14B</b>	14.5" Black	50 Lbs	100
<b>TIEWRAP04N</b>	4" Natural	18 Lbs	1000
<b>TIEWRAP06N</b>	6" Natural	40 Lbs	1000
<b>TIEWRAP08N</b>	8" Natural	50 Lbs	1000
<b>TIEWRAP11N</b>	11" Natural	50 Lbs	100
<b>TIEWRAP14N</b>	14.5" Natural	50 Lbs	100

## TIE LINE

**TIELINE600**  
600 feet  
**TIELINE3000**  
3,000 feet



High strength tieline, also known as trick line, for curtain fastening and cable wrapping. Diamond braided cotton black matte finish, unglazed.



## RAFFAELLO

EL-AS111-LA

Visual stimulation is maximized with this amazing and energetic centerpiece. Raffaello paints the most exciting light show ever seen! Its DMX control allows the user to create a fantastic array of beam combinations and movement. **Specifications:** single powerful MSR 1200 watt lamp source ■ 6 heads consisting of 2 mirrors each, mirror at the end are reflective, second mirror towards end is dichroic glass ■ both mirrors stepper motor controlled in opposite side pairs ■

dichroic glass on each head not only reflects the light but serves as color filter, which by tilting can achieve an extensive variation of color shades ■ 3 gobo/color effect combinations on a carousel containing 3 levels with 6 gobos on each ■ programmable shutter system on each head/black-out by pairs ■ programmable strobing effect ■ continuously rotating mirrored drum ■ stepper motor control ■ DMX512 input control on 10 channels ■ DMX start address selectable ■ 5 pin DMX input and pass thru ■ sound to light mode ■ separate ballast 220v ■ Size: 51"x24.4" ■ Weight: 64Kg/141Lbs ■ Current draw: 12 Amps

## LAMPO



## TINTORETTO PAN & TILT

EL-AS110/P-LA

This extravagant centerpiece effect provides an intense light show. Razor sharp beams which move in both X and Y directions, with vibrant colors and gobo combinations along with shutter chases make this the most versatile machine of its kind. DMX512 control allows you to create an endless number of looks and movements.

**Specifications:** single powerful MSR1200 watt lamp source ■ 6 programmable Pan/Tilt Mirrors ■ pan & tilt movement by stepper motor pairs ■ 3 gobo/color effect combinations on a carousel containing 3 levels with 6 gobos on each ■ programmable shutter system on each head/black-out in pairs ■ programmable strobing effect ■ continuously rotating mirrored drum barrel ■ stepper motor control ■ programmable via DMX512 input control on 10 channels ■ DMX start address selectable ■ sound to light mode ■ separate ballast 220v-50/ 60Hz ■ manual focus of lenses ■ forced fan cooling ■ Size: 38.5"x26.4" ■ Weight: 56.6Kg/124Lbs ■ Current draw: 12 Amps



## DOMINGO

EL-AS76-LA 575w Metal Halide HMI version

This incredible centerpiece effect never goes unnoticed in any venue. Its beams are razor sharp and full of vibrant color. DMX512 control allows you to create an endless number of scenes and chases.

**Specifications:** 8 mirrors working in pairs ■ 6 dichroic colors ■ 8 rotating faceted domes ■ Stepper and dc motor controlled ■ Sound to light mode ■ DMX512 controllable with 5 channels ■ Selectable DMX start address ■ Size: 47"x24.4" ■ Weight: 37Kg/81Lbs ■ Power: 220v-50/60 Hz ■ Current draw: (HMI575) 8 Amps



## DOMINATOR

EL-DOMINATOR/D

Dominator is an outdoor multi-ray aerial effect light fixture. At 6600 watts, the Dominator is absolutely the most powerful outdoor multiray effect on the market today! Its spectacular effect is created by the opening and closing of three circles of 12 rays each. Control it using standard DMX512.

**Specifications:** Lamp: HMD6600 6600w ■ Visibility: approximately 11 kilometers ■ Thermal protection ■ Pan 150 degrees ■ Rotation, open and closing of 3 circles of rays ■ DMX 6 channels: 1-Pan Speed, 2-Flowers, 3-Ray Rotation, 4-Aux, 5-Pan, 6-Aux ■ Weather resistant case ■ Size: 40"x18"x35.8" ■ Weight: 65Kgs/143Lbs ■ Power: 220v-50/60Hz



## SPACEFLOWER

EL-SPACEFLOW3

SpaceFlower is an outdoor multi-ray aerial effect light fixture. Its spectacular effect is created by the opening and closing of three circles of 12 rays each. The version with DMX and shutter even makes it useful for large stage and show performances.

**Specifications:** Lamp: STI 3000w ■ Visibility: approximately 7 kilometers ■ Thermal protection ■ Pan 150 degrees ■ Shutter ■ Rotation, open and closing of 3 circles of rays ■ Controllable via DMX using 6 channels: 1-Pan Speed, 2-Flowers, 3-Ray Rotation, 4-Shutter, 5-Pan, 6-Aux ■ Weather resistant case ■ Size: 27"x17.7"x30.4" ■ Weight: 50Kgs/110Lbs ■ Power: 220v-50/60Hz







**SPACECRAFT**  
**EL-SPACECRAFT**

Shaped like a spacecraft, the spinning action of the mirrored barrel and color changes are an amazing effect. The Mirror barrel projects 5 beams which spread out and

move to the music. 8 brilliant colors, plus white and blackout, along with 8 gobos. Works automatically, in master/slave mode with sound activation or by DMX control. Stepper motor controlled and adjustable focus lens.

**Specifications:** EHV 250w 24v ■ sound activation or DMX512 ■ Power 120v-50/60Hz ■ Current draw: 5 Amps ■ 3-Pin XLR input ■ Size: 24" x 12.2" x 7" ■ Weight: 7.5Kg/16.5Lbs



**STEADY KALIMA**  
**EL-ES15/SK-LA**

Fixed light unit that creates a fan of light tunnels thanks to its special lamp. Can create solid shafts using a different lamp also. Colored lenses available on request. Use 120v

or 230v HX185 800w lamp for tunnel beams effect.

**Specifications:** Lamp HX185 800w ■ Power: 230v or 120v 50/60Hz ■ Current draw: 4 Amps ■ Size: 11.2"x16.9"x13.4" ■ Weight: 5.5Kgs/12.1Lbs



**OCEAN**  
**EL-ES110-LA**

This unique lighting fixture produces a tranquil effect simulating the waves of the ocean. Using a special "S" shaped lamp, light projects through clear lenses which you can gel for your particular color effect. The wave effect is continuous. Best experienced when used with haze or light fog mist.

**Specifications:** Lamp LLP82 800w ■ Continuous rotation ■ Fan cooled ■ Power 230v-50/60Hz ■ Current draw: 5 Amps ■ Size: 14.5"x16.9"x13.4" ■ Weight: 8Kgs/17.6Lbs

**MOJO3 SPIN-MASTER**

**EL-MOJO3**

The MOJO3 features a dual axis spinning mirror barrel. This full-barrel effect radiates streams of colored images over a large area. Strobes, flips and rotates images from its selection of 15 color/gobo combinations. Works automatically, in master/slave mode with sound activation or by DMX control. Stepper motor controlled and adjustable focus lens.

**Specifications:** ELC 250w 24v lamp ■ Sound Activation or DMX512 ■ Input via 3-Pin XLR ■ Power 120v-50/60Hz ■ Current draw: 7 Amps ■ Size: 18.7"x8.7"x6.29" ■ Weight: 7.7Kgs/ 16.9Lbs

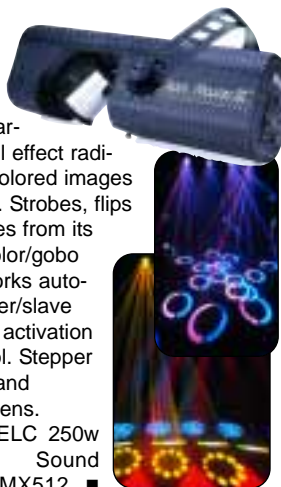

**TUNNEL BEAM**

**EL-SRL436**

The enticing TUNNEL BEAM creates a high speed laser like effect. A rotating wheel provides four changing colors. This distinct effect is also sound active and uses an inexpensive and powerful 300 watt lamp.

**Specifications:** 64514 300w 120v Lamp ■ Sound Activation with Sensitivity Adjustment ■ Fan cooling ■ Power: 120v-50/ 60Hz ■ Current draw: 3 Amps ■ Size: 13"x7.5"x6" ■ Weight: 4.3Kgs/9.5Lbs



**ALPHA**

**EL-SRL402**

An impressive centerpiece in its price range is the ALPHA. Eight powerful beams are dispersed from only one inexpensive lamp. This favorite effect fills any room with a multitude of colored light shafts which dance back and forth to the music.

**Specifications:** EVC 250w 24v Lamp ■ Sound Activation with Sensitivity Adjustment ■ Fan Cooling ■ Power: 120v-50/60Hz ■ Current draw: 4 Amps ■ Size: 15.7"x20.9"x20.9" ■ Weight: 16Kg/35.2Lbs.



**COLOR MIRAGE**

**EL-COLORMIRAGE**



Color Mirage creates a dreamy state of color. Simulates the reflection of light from water. Two modes are available: continuous color change rotation or static color. Static color may be set to one solid color or a bi-color effect as shown in picture above. Uses 6 dichroic colors. Manually focusable lens. Includes adjustable mounting bracket with 1/2" hole in center for clamp mounting.

**Specifications:** ELC 250w 24v Lamp ■ Fan Cooling ■ 6 dichroic colors ■ Power: 120v-50/60Hz ■ Current draw: 3 Amps ■ Size: 10"x10"x7" ■ Weight: 6.6Kgs/14.5Lbs.



**STARLIGHT**

**EL-STARLIGHT**  
Clear lenses  
**EL-STARLIGHT/C**  
Colored lenses

Impressive mirror ball type effect. Great for slow music dancing and disco type lighting. Excellent for larger venues, such as skating rinks. Projects focused multiple beams of colored light while it slowly rotates.  
**Specifications:** Lamp 64514 300w 120v ■ Power: 120v-50/60Hz ■ Current draw: 3 Amps ■ Size: 14"x10"x10" ■ Weight: 7.5Kgs/16.5Lbs



**TRILLY**

**EL-ML414-ML**

The Trilly is a multi-colored moon-flower effect. The multiple strokes of sharp light rotate back and forth to the sound of the music. This cool effect can be used singularly or in multiples. Features Italian grade optics and aluminum extruded body.

**Specifications:** FCS 150w 24v lamp ■ Built in self adjusting audio microphone ■ Power: 120v-50/60Hz ■ Current draw: 2 Amps ■ Size: 12"x8" x7.5" ■ Weight: 6.4Kgs/14Lbs



**HONEYCOMB**  
**EL-HONEYCOMB**

Two multi-faceted reflectors help create wide and stunning beam patterns that are projected through focused colored lenses. The multi-colored ray-tunnels then spin and cross to the beat of the music. Perfect for low ceiling areas and as a center piece effect.

**Specifications:** 2x 64514 300w 120v lamp ■ Power: 120v-50/60Hz ■ Current draw: 6 Amps ■ Size: 13"x12"x17" ■ Weight: 4.08Kgs/ 9Lbs

Specifications are subject to change without notice.

## KALEIDOSCOPE

EL-KALEIDO2



A very bright and colorful kaleidoscope lighting effect using the popular and powerful ENH MR-16 250w 120v lamp source, the same lamp used in professional color changers. Projects a beam through a rotating glass prism filled with many colorful pieces of dichroic glass. Prism can also rotate by selecting on/off switch in back of the unit. Adjustable focus lens.

**Specifications:** ENH 250w 120v MR-16 ■ Fan Cooling ■ Power: 120v-50/60Hz ■ Current Draw: 3 Amps ■ Size: 12"x9.5"x7" ■ Weight: 3.4Kg/7.5Lbs



## SHOOTER

EL-SHOOTER

Is your light show loaded with the Shooter? A high energy effect like no other. Internal rotating dual mirror and dichroics produce shooting strokes out of the 8 lenses. They appear and shift to the beat of the music. Changes colors also. **Specifications:** ENH 250w 120v ■ Power: 120v-50/60Hz ■ Current draw: 3.5 Amps ■ Audio activated by internal microphone ■ Size: 12"x15"x6.75" ■ Weight: 5.5Kgs/12Lbs



## MOONBALL

EL-MOONBALL



The best self contained mirrorball effect available to date. Produces hundreds of thin piercing beams. Effect sits on rotating base. Ideal for mobile or any entertainment venue application.

**Specifications:** 120v/ 300w 64514 lamp or long life 64514X (150 hours) ■ Power 120v-50/60Hz ■ Current draw: 3 Amps ■ Size: 18.7"x11.3"x11.3" ■ Weight: 3.9Kgs/ 8.5Lbs



## DERBY/D

EL-DERBY/D

The linkable Derby/D brings control to the most famous effect ever. Emits 20 intense multi-colored beams which cross back and forth to the beat of the music or by DMX control. Also, features a master/slave mode

for multiple synchronization. Two DMX channels allow control of motor and lamp on/off.

**Specifications:** Lamp: 2x 120v/300w 64514 ■ Sound Activation ■ Fan Cooling ■ Power 120v-50/60Hz ■ Current draw: 6 Amps ■ 3-Pin XLR input ■ Size: 17"x15"x11" ■ Weight: 8Kgs/ 17.6Lbs



## DOUBLE DERBY/D

EL-DDERBY/D

Like the traditional Double Derby but better! Creates 40 intense multi-colored beams which criss-cross back and forth to the music.

Very bright effect ideal for entertainment venues and mobiles who want total show control. Units are linkable in master/ slave mode or via DMX. Two DMX channels allow control of motor and lamp on/off.

**Specifications:** Lamp: 2x 120v/300w 64514 ■ Sound activation ■ Fan cooling ■ Power: 120v-50/60Hz ■ Current draw: 6 Amps ■ 3-Pin XLR input ■ Size: 17"x15"x11" ■ Weight: 10Kgs/ 22Lbs



## MUSHROOM/D

EL-MUSHROOM/D

Projects multi-colored beams that criss-cross back and forth and rotate. This fixture ranks in the Top 5 DJ favorites. It is light weight and features an internal microphone for sound to light activation or can be controlled via DMX.

**Specifications:** 2x 64514 300w 120v Lamp ■ Sound Activation or DMX512 ■ Fan cooling ■ Power: 120v-50/60Hz ■ Current draw: 6 Amps ■ 3-Pin XLR DMX input ■ Size: 14"x10.5"x10.5" ■ Weight: 3.4Kgs/7.5Lbs



## GOBLIN

EL-GOBLIN

Projects multi colored flats blades that rotate to the music back and forth. Light-weight and great for mobile or permanent installations. Long lasting economical lamp.

**Specifications:** Lamp EHM 300w 120v R7s ■ Sound Activation with Sensitivity Adjustment ■ Fan cooling ■ Power: 120v-50/60Hz ■ Current draw: 3 Amps ■ Size: 13"x14"x8" ■ Weight: 6.8Kgs/15lbs



## DERBY

EL-ES27/N-LA

## LAMPO

Nothing like the original DERBY by LAMPO. The legend continues with its powerful dual 400w lamps. 16 intense multi-colored beams which cross back and forth to the beat of the music.

**Specifications:** 2x EVD 400w 36v Lamp ■ Sound Activation ■ Fan cooling ■ Power 120v-50/60Hz ■ Current draw: 8 Amps ■ Size: 18.9"x17.3"x11.8" ■ Weight: 16.5Kgs/ 36.3Lbs



## THE BEACONS

Great for mobile and permanent installations, the police beacons are a novelty hard to pass up. The spinning beam is a great attention getter especially in store fronts. Two sizes and three different colors are available. X in order code represents Red, Blue and Amber.

**EL-BEACON1X** Lamp: 75w 120v E27 ■ Size: 8.6"x8.6"x9." ■ Weight: 2.5Kgs/ 5.5Lbs

**EL-BEACON2X** Lamp: 25T8DC 25w 120v ■ Size: 5.7"x5.7"x7.1" ■ Weight: 1.5Kgs/3.3Lbs



EL-BEACON2X



## COLOR MOON

EL-COLORMOON/D

The new Color Moon sets the standard. Sharp beams and rich dichroic colors rotate back and forth making this the best moon flower effect ever.

Its new synchronization feature makes it even more spectacular when used in multiples. Uses precision stepping motor and 8 dichroic filters. Linkable in master/slave mode to the beat of the music or by DMX control. **Specifications:** ENH 250w 120v Lamp ■ Power: 120v-50/60Hz ■ Current draw: 2.5 Amps ■ 3-Pin XLR input for DMX ■ Size: 13.8"x8.7"x7.9" ■ Weight: 9Kgs/20Lbs



## MICROUFO

EL-MICROUFO

It's a baby spinning saucer! 8 colored-flat beams spin around and out of the bottom shoots a colored moonflower. Great for bars, party supply stores and mobile DJs who want something which is compact and effective.

**Specifications:** 64514 300w 120v ■ Power: 120v-50/60Hz ■ Current draw: 3.5 Amps ■ Size: 8.5"x8.5"x11" ■ Weight: 3.2Kgs/ 7Lbs



# PS & E PROFESSIONAL SERVICES

PS&E design services are available to assist with projects and individual show designs. Our on staff designer is a member of the International Association of Lighting Designers (IALD) and is able to provide over 25 years of design and touring experience to help develop your vision. Utilizing a state of the art computer system and rendering farm provided by an exclusive partnership with Render Blender, a building or show can be brought to life and lights reviewed and tested months before installation. Consultation, review and design services are available for any size project through our dealer network. We have helped many clients achieve their dream systems with savings on utilities and construction through proper design and consultation. The final product can be presented in working drawings, animations, photo quality renderings or slide shows. Our design staff is ready to help you, help yourself. Our clients have included Universal Studios, Forestville Baptist Church, Wet n Wild, Regina Casino, US Grant Hotel, Tivoli Gardens Copenhagen and City Bible Church Oregon to name a few. Call today and discuss your project dreams with us. A demo DVD is available on request or visit our website at: [www.Techni-Lux.com](http://www.Techni-Lux.com) and click on "Design Services".



Demo DVD Available

## DESIGN

We can help you with equipment selection, layout and coordination while guaranteeing that all of your needs are met through proper and efficient design. Whether you are working with a small community show or a full size building design we are available to assist you with Architectural, Retail, Club, Theatrical, Touring and House of Worship design services. Full consultation and project review services are also available to work with your team. We can also provide project specific control and automation systems fully customized and built by our engineering teams. A properly designed project will be easier to envision and sell and often saves money.

## RENDERING & ANIMATION

Techni-Lux is proud to be the exclusive provider of Render Blender, LLC. Through this partnership we can provide high quality animations and renderings of your project. Whether you need to see that camera shot or want to virtually walk through your concept, our animation services can make that happen. We can also work with and enhance your existing WYSIWYG drawing and then provide photo realistic renders of the lighting. We can provide drawings up to 36" x 48", pipe tapes, DVD quality animations and clean up services. Render Blender LLC is a Certified Service Provider (CSP) for Cast software.

## SIMULATION SUITE & TRAINING

At our Orlando headquarters we offer a 400 square foot programming and training suite with fixtures and consoles. This space can be rented to help you pre-program a show before you are in the facility or before the site is available, saving thousands on time and rental fees. Consoles can be connected to a high speed computer which will project a wall sized image of the space in a real time lighting simulation. Training is offered for a complete line of lighting consoles and fixtures along with a library of lectures and seminars. An Authorized WYSIWYG Trainer (AWT) is on staff. Contact us about our upcoming class schedule.

## PROGRAMMING

We have a team of programmers available to help with any size show or project. We have extensive experience in Theatrical, Architectural, Themed Attraction and Event programming for Theatres, Casino's, Cruise Ships, House of Worship and a variety of specialty venues. We can provide system layout, patching, fixture assignment, cueing, show dissemination, timecode and automation. Programming work can be done in our office, on-site or a combination of both. A lighting system and design is only as good as its execution and programming is a large part of the overall finished product.

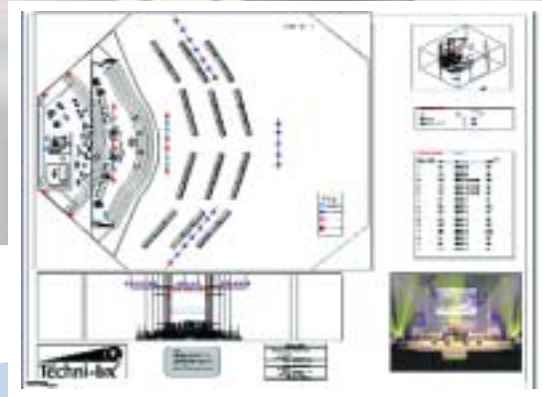



Rev 06.1

Pro Sound & Electrical • Orlando, FL • (407) 468-3396 • Fax: (407) 226-0194 •

[www.prosoundelectrical.com](http://www.prosoundelectrical.com)

Copyright © 2002-2006. Pro Sound & Electrical. All rights reserved.  
Specifications subject to change without notice. Not responsible for typographical errors.