



Lighting Catalog

Over the past eighteen years, Pro Sound & Electrical has created many valuable relationships. These relationships are with you, our clients. Our commitment and dedication to manufacturing and distributing into the lighting industry has permitted Pro Sound & Electrical to grow at an enormous rate. Your continued response confirms that we exceed your expectations with outstanding performance.

We've learned that you deserve the best service and attention, a friendly knowledgeable staff, technical support, a large inventory selection, quality products and lastly, a competitive price. Achieving these has been our objective and reward. By focusing exclusively on lighting, we are able to lead in both innovative technology and superior customer support. Today, with wide variety and reliability, Pro Sound & Electrical supplies the needs of lighting professionals throughout the world. Pro Sound & Electrical will continue to strive for customer satisfaction and in defining the lighting trends of the future.

Thank you!

- 1** LED Digital Lighting
- 15** Moving Heads
- 22** Architectural Lighting
- 24** Scanners
- 26** Followspots
- 27** Pin Spots
- 28** Color Changers & Par Cans
- 29** Film/Studio/T.V./Theatrical
- 33** Controllers
- 38** Chasers/Switching
- 39** Dimmers
- 40** Interfaces
- 41** Accessories
- 44** Fog Machines
- 45** Haze Machines
- 46** Fog & Haze Fluids
- 47** Strobe Lights
- 48** Special Effects
- 49** Specialty Lighting
- 50** Stands & Grip Equipment
- 50** Safety Cables
- 51** Trussing & Sandbags
- 52** Clamps
- 54** Motor Hoists
- 55** Power & Data Connectors
- 57** Rope Lighting
- 58** Gobos
- 59** Expendables
- 62** Effect Lighting
- 64** Laser Lighting
- 65** Design Services

Index

Acetates.....	27	Fluorescent Soft	32	Protocol Convertor.....	40
Adapters.....	55	Fog Fluid.....	46	Reflectors.....	28
Airwall Hanger	53	Fog Machines.....	44	Regia Consoles.....	33
Alpha.....	62	Fog Scents.....	46	Rendering.....	65
Alumalok.....	53	Follow Spots.....	26,27	Ribalta.....	14,30
ArchILED.....	9	Foot Controller.....	36	Rope Lighting.....	57
Arena.....	27	Fresnels.....	30	RotoGobo.....	58
Artist.....	35	Fusion.....	1	Safety Cables.....	50
Bank Lights.....	1,30	Galileo.....	25	Sandbags.....	51
Barndoors.....	28	Gel Tape.....	61	Scanners.....	24,25
Bases.....	50	Gel.....	59	Shiva.....	24
Bates Stage Pins.....	56	Genio.....	14	Smart Control.....	34
Batteries.....	60	Giotto.....	16-19	Smoke Machines.....	44-45
Beacons.....	62	Goblin.....	63	Snow Machine.....	48
Blacklights.....	6,49	Gobo Projector.....	58	Spacecraft.....	62
Blinder Lights.....	1,30	Gobos.....	58	Spaceflower.....	63
BLISS Laser Lights.....	64	Gobo Holder.....	58	Socapex.....	57
Bubble Machine.....	48	Gooseneck Lights.....	42	Splitter DMX.....	41
Bulbs.....	60	Grip Stands.....	50	Stage Pin.....	56
Cables.....	55	Haze Machines.....	45	Stage Tape.....	61
Cam Connectors.....	57	Hoists.....	54	Stands.....	50
Chain Motors.....	54	IdeaLED.....	15	Starlight.....	62
Chasers.....	38	Idea Moving Heads.....	16	Strip Lights.....	1,30
Cheeseboroughs.....	52	Kaleidoscope.....	63	Strobes.....	47
Color Changers.....	28	Lamps.....	60	Switch Packs.....	39
Color Filters.....	59	LED Lights.....	1-15, 29	Synthesis.....	17
Colored Lenses.....	27	LEO.....	31	Tapes.....	61
Colormoon.....	62	Leprecon Rack.....	40	Terminator.....	55
ColorRGB.....	28	Light Dome.....	18	Tie Line.....	60
Commander.....	36	Light Shaping Filters.....	60	Tie Wraps.....	60
Connectors.....	55-57	Lighting Stands.....	50	Touch Panel.....	36
Console Tape.....	61	Littlites.....	42	Topaz.....	39
Controller.....	33-37	Matte Wrap.....	61	Tracer.....	26
Cool Lights.....	32	Mega Clamp.....	53	Tracker.....	21
CS4.....	20	MicroTech.....	41	Trick Line.....	60
Cyclorama Light.....	30	MicroUFO.....	62	Trilly.....	62
D/A Converter.....	40	Mini City.....	22	Triple Tap.....	54
Data Cables.....	55	Minibrut.....	30	Tripods.....	50
Derby.....	63	Miniluz.....	30	Trussing.....	51
Design Services.....	65	Mirror Ball Motors.....	49	Truss Picks.....	52
Digi-Fan.....	48	Mirror Balls.....	49	Tube Covers.....	59
Dimmer Packs.....	39,40	Mojo Scan.....	24	Tunnel Beam.....	62
DMX Controllers.....	33-37	Motor Controls.....	54	Twist Connectors.....	56
DMX Master.....	37	Motor Hoists.....	54	Ultimate 2000-3000.....	45
DMX Splitters.....	41	Moving Heads.....	15-21	Ultra-Gel.....	59
Dominator.....	63	Mushroom/D.....	63	UltraLED.....	2-8
Double Derby.....	63	Newton.....	26	Ultralight LED.....	29
Duct Tape.....	61	Ocean.....	62	Underwater LED.....	10,11
Edison Plugs.....	56	Operator.....	36	UV Lights.....	6,49
Effect Lighting.....	62,63	Oscillators.....	27	Victory.....	25
Egg Strobe.....	47	Outstation.....	41	Wind Tunnel.....	48
Electrical Tape.....	61	Pack1.....	38	Windup.....	50
Elevator.....	50	Palco.....	12,13	Wireless DMX.....	41
Elite Fog/Haze Fluids.....	46	ParBar.....	29	WYSIWYG.....	33,65
Ellipsoidals.....	31	ParCan Accessories.....	28	XLR Connectors.....	55
Expendables.....	59-61	ParCans.....	28	XS1200.....	20
Extension Cords.....	55	Pilot Consoles.....	34	Zip Ties.....	60
Fan.....	48	Pin-Spots.....	27		
Fastlock.....	52	Power Cables.....	55		
Filters.....	59	Power Center.....	38		
Flasher.....	47	Power Connectors.....	56,57		
FlexiPar.....	29	Procell Batteries.....	60		
Floor Base.....	50				

Affiliations:



LED PAR16 RGB LIGHT

The PAR16RGB Series is the easiest and fastest way to add color lighting to any environment using the latest in LED color technology. Just connect it into any standard light socket, screw-in or pins, and turn it on. The PAR16RGB Series is a simple way to allow control and selection of 16 colors, 4 dimming levels and several color changing modes with no wiring. Simply point the IR remote and make your selection. Multiple units may either be set to same color or alternate colors as you desire to create any mood. Install and set a look in just minutes! Applications: living or media rooms, restaurant dining areas, museums, hotel lobbies, ambient mood lighting in any room, haunted houses, theme park rides



DL-PAR16RGB3I/G

Specifications: LEDs - 3 x 1w of Red, Green, Blue
 ■ Color system: RGB - 16 colors ■ Wattage: 3w ■ 4 levels of dimming ■ Base: 2 pins GX5.3 ■ Average led life: 10,000 hours ■ Front protection lens and rear heat sinking ■ Control using IR remote sold separately ■ Power: 9-18vAC or 10-20vDC 47/63 Hz ■ Power consumed: 5 watts ■ Size: 2"x1.97" Diameter ■ Weight: 0.08Kgs/0.17Lbs ■ Color: White body/Silver chrome front

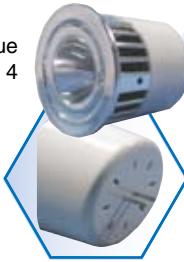

DL-PAR16RGB3I/E26

Specifications: LEDs - 3 x 1w of Red, Green, Blue
 ■ Color system: RGB - 16 colors ■ Wattage: 3w ■ 4 levels of dimming ■ Base: Edison screw-in E26/E27 ■ Average led life: 10,000 hours ■ Front protection lens and rear heat sinking ■ Control using IR remote sold separately ■ Power: 90-230Vac 47/63 Hz ■ Power consumed: 5 watts ■ Weight: 0.10Kgs/0.24Lbs ■ Size: 3.94"x1.97" Diameter ■ Color: White body/Silver chrome front



RGB IR Remote

CT-RGB3IR/RM

Use the RGB IR REMOTE to control the PAR16RGB3I light fixtures. Just point it at the PAR16RGB3I lamps and make selection by pressing buttons to make quick changes.



Specifications: 31 total buttons n On/Off control ■ Selection of 16 colors with individual keys ■ Selection of 4 levels of dimming ■ Selection of fade modes ■ Allows lock & unlock for each fixture ■ Power: 2 x AAA Batteries ■ Weight: 0.10Kgs/0.22Lbs ■ Size: 6.25"x2.38"x0.63" ■ Color: Black

DL-PAR16RGB3I/LF

Specifications: LEDs - 3 x 1w of Red, Green, Blue
 ■ Color system: RGB - 16 colors ■ Wattage: 3w ■ 4 levels of dimming ■ Base: round white plastic base included ■ Average led life: 10,000 hours ■ LED lamp with Front protection lens and rear heat sinking ■ Control using IR remote sold separately ■ Power: 100-240Vac 47/63 Hz with wall transformer included ■ Power consumed: 5 watts ■ Size: 4.06" Base Diameter x 5.63" max Height ■ Weight: 0.37Kgs/0.81Lbs ■ Color: White body with Silver chrome front LED lamp



RAGGIO 36 IP65

DL-RAGGIO36



The Raggio is a professional high power RGB LED color mixing projector with selectable beam angle optics for indoor or outdoor use. Allows the creation of millions of colors. It is suitable for outdoor use, industrial shows, theatre, tradeshow and production use. Order one required CT-DLC900 device to set DMX addresses.



Specifications: High power LEDs – total 36 x 3W – 12 red, 12 green, 12 blue ■ Color changer RGB system ■ Efficient optical system ■ Beam angle options available by changing lenses: Narrow Spot 15° or Flood 30° ■ IP65 Rating makes it weather resistant ■ Average LED life: 100,000 hours ■ Body: Die-cast aluminum ■ DMX512 using 5 channels ■ Power Consumption: 48 watts ■ Current draw: less than 1 amp ■ Power: 120/240vAC, 50/60Hz ■ Size: 14.8"x11.5"x16.3" ■ Weight: 6.2Kgs/14Lbs

FUSION

DL-FUSION



The Fusion is a professional high power RGB LED color mixing projector with selectable beam angle optics. Allows the creation of millions of colors. It is suitable for industrial shows, theatre, tradeshow and production use.



Specifications: High power LEDs - 18 x 3W ■ Color changer RGB system ■ Wattage: 54w ■ Current draw of less than 1 amp ■ Average led life: 100,000 hours ■ Efficient optical system ■ Beam angle options available by changing lenses: VN5P 6°, NSP 15°, WFL diffusion 68° x 55° ■ DMX512 using 5 channels ■ 5 pin XLR input ■ Power: 120Vac 50/60 Hz ■ Weight: 6.5Kgs/14.33Lbs ■ Size: 14.8"x11.5"x16.3"

STRIP LITE RGB

DL-STRIPLITE301 30 x 1w LEDs
 DL-STRIPLITE303 30 x 3w LEDs



Specifications: 30 LEDs (10 red, 10 green, 10 blue) ■ Low Power consumption ■ Minimal heat emission ■ Controlled using DMX 512 ■ DMX Channels: 3 ■ DMX In/Out: 5 pin XLR ■ Data Settings: via display ■ Power: 100-240vAC 50/60Hz ■ Weight: 13Kgs/28.7Lbs ■ Size: 45.3"x7.9"x11.8"

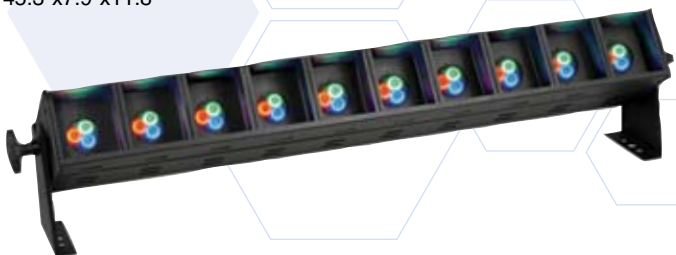

LEDBANK 4 BLINDER

DL-LEDBANK4-3TC

The LEDBANK4 uses high output 3w Trileds to produce the best possible BLINDER effect since the blending itself occurs at the source of each LED lens. By using Tri-color RGB LEDs, it can both color mix smoothly and still produce a great "white light" blinding effect.



Specifications: Light source: 24 x 3w RGB Trileds - divided into 4 sections of 6 Trileds ■ Beam angle: 25 degree lenses ■ Settings: Using LCD Display and push buttons ■ DMX Channels: 6, 9, or 15 channels ■ DMX Data In/Out: 3 pin XLR ■ Built-in 14 programs, Auto mode, DMX mode, Master / slave mode and sound activation mode ■ Internal modes with programmable speed time, fade time and flash rate ■ Body: Aluminum housing ■ Mounting: include yoke with 1/2" clamp mounting hole ■ Power consumption: 80 watts ■ Power: auto-ranging 100-240vAC 50/60hz ■ Size: 16.14"x17.32"x5.91" ■ Weight: 6Kgs/13.2Lbs ■ Color: Black

UltraLED SERIES



ULTRALED MR16 INGROUND HOUSING

DL-ULEDMR16INS

UltraLED MR16 Inground Housing Only for **DL-ULEDMR16** - Stainless Steel
Specifications: Size: 3.86"Diameter x 3.82"x2.44"
 ■ Weight: 0.70Kgs/1.54Lbs ■ Color Finish: Stainless Steel



ULTRALED MR16 OUTDOOR LANDSCAPE HOUSING

DL-ULEDMR16LSS

UltraLED MR16 Outdoor Landscape Housing Only for **DL-ULEDMR16** - Stainless Steel
Specifications: Size: 3.15"Diameter x 3.6"x2.95" ■ Weight: 0.80Kgs/1.76Lbs ■ Color Finish: Stainless Steel

LONG FROSTED GLASS DECORATIVE TUBE - 20CM

DL-ULEDMR16FTL

Specifications: Size: 49mm diameter x 207 cm long ■ Weight: 0.50Kgs/1.1Lbs ■ Available in the four colors: Gold, Black, Silver, White. ■ Includes Adapter Ring.



Adapter Ring

SHORT FROSTED GLASS DECORATIVE TUBE - 8CM

DL-ULEDMR16FTS

Specifications: Size: 49mm diameter x 87 cm long ■ Weight: 0.20Kgs/0.44Lbs ■ Available in the four colors: Gold, Black, Silver, White. ■ Includes Adapter Ring.

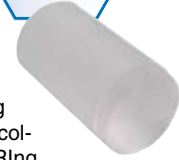

ULTRALED MR16 CEILING / WALL MOUNT RING

DL-ULEDMR16RX (X= Color Trim Finish)

UltraLED MR16 Ceiling / Wall Mount Ring for flat recessed mounting of DL-ULEDMR16TC9

Specifications: Size: 3.15"Dia. x .79"D ■ Weight: 0.08Kgs/0.176Lbs ■ Color Trim Finish: DL-ULEDMR16RB Black, DL-ULEDMR16RW White, DL-ULEDMR16RG Gold, DL-ULEDMR16RS Silver



RECESSED EYEBALL CEILING/WALL MOUNT

DL-ULEDMR16RXE (X= Color)

UltraLED MR16 Ceiling / Wall Recessed Mount Eyeball Ring for DL-ULEDMR16 - White. Allows you to aim the MR16 beam output.

Specifications: Size: 3.9"x3.9"x1.8" ■ Weight: 0.15Kgs/0.33Lbs ■ Available in the four colors: Gold, Black, Silver, White.



ULTRALED MR16 DL-ULEDMR16TC9

The 9 watt UltraLED MR16 Tricolor engine allows the use of MR16 type fixtures to illuminate with a smooth RGB output beam. Many fittings and options are available for mounting this MR16. Features high power 3 x 3w tricolor LEDs and is fitted with 16 feet of cable. Comes equipped with 45 degree flood beam spread lenses, however, lenses are interchangeable with optional 10, 15, 25, and 30 degree lenses. 4 of these ULEDMR16TC9 units can be used on each output of the ULEDDRIVER4, allowing the use of 16 units from a single ULEDDRIVER4 power and control unit.

Specifications: 3w x 3 Edison Trileds ■ Size: 1.97"Dia. x 3.2"D ■ Weight: 0.3Kgs/0.66Lbs

ULTRALED MR16 DL-ULEDMR16TC3

Specifications: 1 x 3W tricolor LEDs ■ LED brand Edison ■ Power consumption: 3.5W max ■ Beam angle: 15, 45 (pre-installed) ■ IP20 ■ 16ft cable ■ Standard MR16 housing ■ Size: 2"x2"x2.6" ■ Weight: 0.35Kgs/0.77Lbs



ULTRALED MR16 DL-ULEDMR16WW3

Specifications: 3 x 1W cool white LEDs (one each cool white, warm white and amber) ■ LED brand Edison ■ Power consumption: 3.5W max ■ Color temperature: 6000k cool white, 2800k warm white, Amber (wave length: 595nm) ■ Beam angle: 10, 15, 25, 30, 45 (pre-installed) ■ IP20 ■ 16ft cable ■ Standard MR16 housing ■ Size: 2"x2"x2.8" ■ Weight: 0.35Kgs/0.77Lbs



ULTRALED MR16 DL-ULEDMR16CW3

Specifications: 3 x 1W cool white LEDs ■ LED brand Edison ■ Power consumption: 3.5W max ■ Color temperature: 6000k ■ Beam angle: 10, 15, 25, 30, 45 (pre-installed) ■ IP20 ■ 16ft cable ■ Standard MR16 housing ■ Size: 2"x2"x2.8" ■ Weight: 0.35Kgs/0.77Lbs



ULTRALED MR16 YOKE MOUNTING BRACKET

DL-ULEDMR16Y

UltraLED MR16 Yoke Mounting Bracket for **DL-ULEDMR16TC9** - Silver

Specifications: Size: 3.62"H x 1.54"W x 1.73"D ■ Weight: 0.17Kgs/0.37Lbs



Specifications are subject to change without notice.

UltraLED SERIES

UltraLED DRIVER PSU DL-ULEDDRIVER4



A 4 output power and control unit for the UltraLED series range of products. Compact and easy to use.

Specifications: 4 current output ports of 36 watts each plus 2 voltage outputs, total 144 watts ■ DMX control using 6, 12, 18, or 24 channels ■ Operation modes include Auto, Sound Active, DMX, and Master/Slave ■ Built-in 18 color presets, various stepped and fading chase programs with variable speed control ■ Software updateable via USB port ■ LCD digital display menu for all settings ■ Remote access to stand alone features from DMX ■ 100-240vAC 50/60Hz worldwide supply compatible ■ Can be wall mounted, free standing, or clamp mounted. ■ Size: 11.38"x8.86"x3.11" ■ Weight: 2.2Kgs/4.9Lbs

UltraLED DRIVER RACK MOUNT PSU DL-ULEDDRIVER12R



A 12 output power and control unit for the UltraLED series range of products.

Specifications: 8 current output ports of 36 watts each plus 4 voltage outputs, total 432 watts ■ DMX control using 6, 12, 18, or 24 channels ■ Operation modes include Auto, Sound Active, DMX, and Master/Slave ■ Built-in 18 color presets, various stepped and fading chase programs with variable speed control ■ Software updateable via USB port ■ LCD digital display menu for all settings ■ Remote access to stand alone features from DMX ■ Power: 120v or 230vAC 50/60Hz selectable by switch ■ 2U Rack Mount Unit ■ Size: 19"x3.5"x10" ■ Weight: 5Kgs/11Lbs



LED RGB LINEAR RIBBON FLEX DL-ULEDFLEX/TC

LED Ribbon Flex is an innovative product which incorporates a flexible circuit board and cutting edge RGB 3-in-1 SMD LED. The flexible PCB can be bent to a maximum radius of 2 cm. LED Ribbon Flex is dimmable and color controllable. LED Ribbon Flex is designed for long linear applications, complex signage, cove lighting and structures, convex, concave and other curved surfaces and objects. It is very low profile and fits in a very small area.

Specifications: Flexible ribbon with a minimum bend radius of 2cm ■ SMD 0.2w LED RGB technology (16.7 million colors) ■ Beam angle: 120 degrees ■ 256 levels of dimming from 0 – 100% ■ Controlled and powered using *DL-ULEDDRIVER4* or *DL-ULEDDRIVER12* ■ LED Spacing: 27.8mm apart ■ Cutting length: every .3 meters, 12 LEDs ■ Rating: IP65 ■ Power: 48vDC ■ Roll Wattage: 36 watts ■ Roll Size: (L) 5m x (W) 12mm x (H) 3mm ■ Weight: .4Kgs/.8Lbs ■ Accessories Included: 20 mounting clips and 10 end caps

UltraLED DRIVER PSU OUTPUT PORT SPLITTER DL-ULEDSPLIT2B



Easy and quick way to split one UltraLED Driver 4 output into 2 individual outputs. Features standard RJ45 connectors points for 1 in 2 out. Includes one 2 meter black cable for jumping from from one splitter to another splitter.

Specifications: 1 in, 2 out RJ45 cube connector ■ Size: 1.3"x1.14" x .91" ■ Weight: 0.02Kgs/0.044Lbs ■ Color: Beige

EXAMPLE CONFIGURATIONS

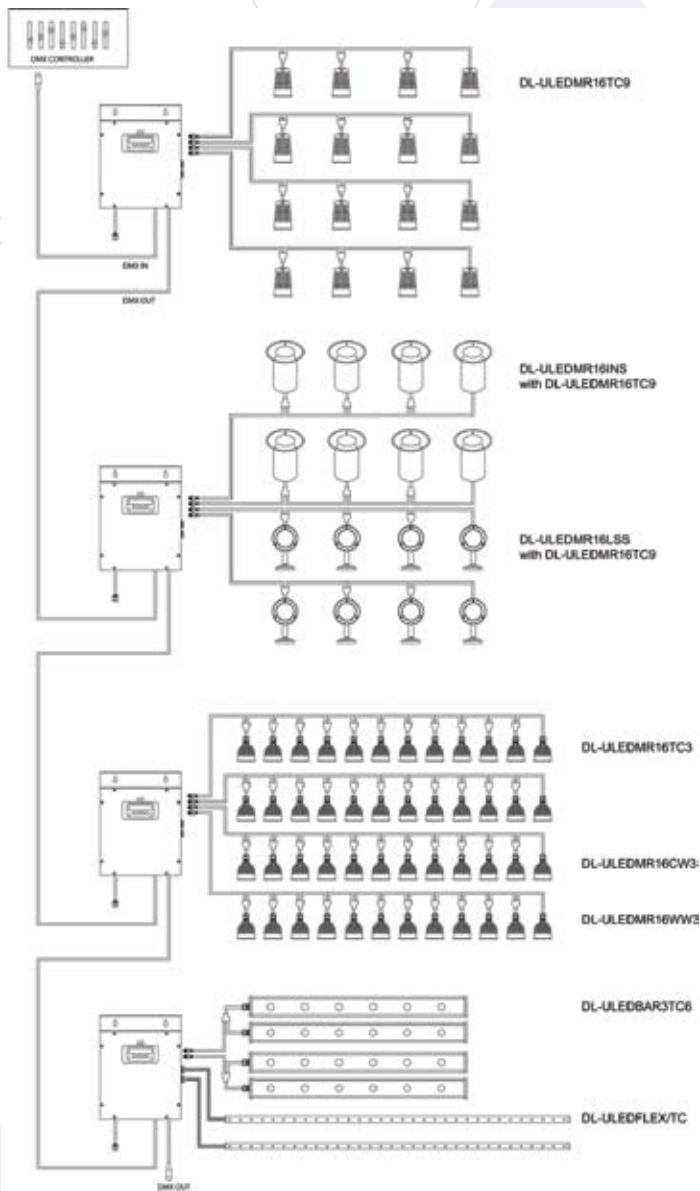

UltraLED BAR 6 DL-ULEDBAR3TC6

Specifications: 6 x 3W tricolor LEDs ■ LED brand Edison ■ Power consumption: 18W ■ Beam angle: 10, 15, 25, 30, 45 (pre-installed) ■ IP65 ■ 16ft cable ■ Size: 17.9"x1.1"x3.1" ■ Weight: 1.3Kgs/2.9Lbs



Specifications are subject to change without notice.

LED Digital Lighting

Ultra **LED** SERIES

FlexiLED TriColor

DL-FLEXILED3TC18/B RGB LEDs, Black Case
DL-FLEXILED3TC18/W RGB LEDs, White Case

The FlexiLED Tricolor features high power trichromatic LEDs producing a uniform color output out of each individual lens. The specially designed lenses combine the focused RGB light into a coherent and single source output. By emitting all RGB colors out of each lens, this unit reduces the amount of color abrasion on the edges of images and their shadows, thus producing a cleaner beam of light. When looking at this unit, the light output appears all to be the same color without seeing the RGB separation in each of the lenses. The FlexiLED Tricolor uses the latest in control technology to produce the smoothest dimming curve possible. The FlexiLED Tricolor is perfect for many applications and venues including theatres and TV studios.



Specifications: Power Input: 120vAC or 220vAC, 50/60Hz ■ 18 high powered trichromatic all driven at 3 watts, 700ma ■ Beam angle: 25° lens standard ■ Optional beam lens angles (sold separately): 45 or 60 degrees ■ Includes Color/Filter holding Frame ■ Thermally cooled internally by heat sink case and noiseless fan ■ Control: Sound, auto, master/slave and DMX ■ On-board LCD display menu with 4 push buttons for settings ■ Multiple modes include: a DMX 3, 4, 5 or 6, manual color settings, internal programs, master / slave using sound and auto speed settings ■ Maximum DMX Channel Mode: Ch1 - Master Dimmer, Ch2 - Red level, Ch3 - Green level, Ch4 - Blue Level, Ch5 - Macro, Ch6 - Strobe ■ DMX In/Out: 5-pin XLR connectors ■ Heavy duty, light weight die cast aluminum housing ■ Yoke with 1/2" clamp mounting hole ■ Size: 11"x12"x10" ■ Weight: 3.86Kgs/8.5Lbs ■ Color: Black or White

FlexiLED RGBW

DL-FLEXILED1C30/B RGBW, Black Case

Using high power 1 watt red, green, blue and white LEDs allows the FlexiLED RGBW to produce a vast array of well balanced color mixes. The FlexiLED RGBW uses the latest in control technology to produce the smoothest dimming curve possible. All FlexiLED units feature a filter frame holder which may be combined with LSD filters to better tailor the beam shape for many applications and events.



Specifications: 8 Red, 8 Green, 8 Blue and 6 White LEDs ■ Total 30 x 1 watt LEDs ■ Beam angle: 8° lens standard ■ Optional beam lens angles: 10, 15, 25, 30, 45 degrees ■ Includes Color/Filter holding Frame ■ Thermally cooled internally by heat sink case and noiseless fan ■ Control: Sound, auto, master/slave and DMX ■ On-board LCD display menu with 4 push buttons for settings ■ Multiple modes include: a DMX 4, 5, 6 or 7 channel mode, manual color settings, internal programs, master / slave using sound and auto speed settings ■ Maximum DMX Channel Mode: Ch1 - Master Dimmer, Ch2 - Red level, Ch3 - Green level, Ch4 - Blue Level, Ch5 - White Level, Ch6 - Macro, Ch7 - Strobe ■ DMX In/Out: 5-pin XLR connectors ■ Rugged light weight die cast aluminum housing ■ Dual stand yoke with 1/2" clamp mounting hole ■ Power Input: 120vAC or 220vAC, 50/60Hz ■ Power Consumption: 48 watts ■ Size: 11"x12"x10" ■ Weight: 4Kgs/8.8Lbs ■ Color: Black

FlexiLED Zoom

DL-FLEXILED3C24Z/B RGB LEDs, Black Case

The FlexiLED Zoom is a new generation of "flexible" LED Par Fixtures encompassing the latest LED technology and controlling electronics. The LED arrangement and special optical system produces an optimized even beam field at maximum light output. What makes the FlexiLED Zoom so flexible is the fact that you don't need to purchase the unit in a specific beam angle or even get any additional lenses to change. You can now adjust your beam angle spread directly from your console by simply varying the zoom channel. It provides a remote zoom focus without the need of changing any lenses. The unique motorized mechanics enables linear zooming between a very narrow 6 degrees to a very wide 60 degree spread, making it a very versatile fixture for any application.



Specifications: Power Input: auto-ranging 80 - 250vAC, 50/60Hz ■ 24 Luxeon Rebel LEDs, 8 each of red, green and blue all driven at 3 watts, 700ma ■ Beam Angle: 6°- 60° motorized zoom remotely adjustable ■ On-board LCD display menu with 4 push buttons for settings ■ Includes Color/Filter holding Frame ■ Thermally cooled internally by heat sink case and noiseless fan ■ Control: sound, auto, master/slave and DMX ■ Multiple modes include: a DMX 4, 5, 6, or 7 channels, manual color settings, internal programs, master / slave using sound and auto speed settings ■ Sound sensitivity adjustable from 0 - 100% ■ Maximum DMX Channel Mode: Ch1 - Master Dimmer, Ch2 - Red level, Ch3 - Green level, Ch4 - Blue Level, Ch5 - Macro, Ch6 - Strobe, Ch7 - Linear Zoom ■ DMX In/Out: 5-pin XLR connectors ■ Heavy duty, light weight die cast aluminum housing ■ Yoke with 1/2" clamp mounting hole ■ Size: 11"x12"x10" ■ Weight: 5Kgs/11Lbs ■ Color: Black



TRICOLOR

LEDPar Outdoor

DL-LEDPAR1C360/B RGB LEDs, Black Case
DL-LEDPAR1C360/S RGB LEDs, Silver Case

The LEDPar Outdoor is a new generation of intelligent LED based lighting fixtures. Completely optimized, the LEDPar Outdoor uses the latest in electronic LED control to regulate and reduce premature LED burnouts. The LEDPar features 36 x 1 watt high brightness Red, Green and Blue leds which produce great color balance. The IP 65 rating makes this unit perfect for outdoor weather or standard indoor use. Dual yoke allows the unit to be stood on the floor or clamp mounted as needed.



Specifications: Power Input: auto-ranging 80 - 250vAC, 50/60Hz ■ 36 high output LEDs, 12 each of red, green and blue all driven at 1 watt, 350ma ■ Beam angle: 15° lens standard ■ Optional beam lens angles (sold separately): 25 and 45 degrees ■ Thermally cooled internally by heat sink case ■ Control: Sound, auto, master/slave and DMX ■ On-board LED display menu with 4 push buttons for settings ■ Multiple modes include: a DMX 3, 4, 5 or 6, manual color settings, internal programs, master / slave using sound and auto speed settings ■ Maximum DMX Channel Mode: Ch1 - Master Dimmer, Ch2 - Red level, Ch3 - Green level, Ch4 - Blue Level, Ch5 - Macro, Ch6 - Strobe ■ DMX In/Out: 3-pin XLR connectors ■ Rating: IP 65 for outdoor use ■ Heavy duty, light weight die cast aluminum housing ■ Dual yoke with 1/2" clamp mounting holes, for hanging or floor standing ■ Size: 9.5"x11"x7.25" ■ Weight: 3.86Kgs/8.5Lbs ■ Color: Black or Silver

Specifications are subject to change without notice.

LEDPAR OUTDOOR TRICOLOR

DL-LEDPAR3TC360/B

LEDPAR Outdoor TriColor is the next generation in this weather resistant series. The high power 3 watt trichromatic LEDs produce a bright and uniform color output. The specially designed lenses combine the focused red, green, and blue light into a coherent and single source output. By emitting all three RGB colors out of each lens, this unit reduces the amount of color abrasion on the edges of images and their shadows, thus producing a cleaner beam of light. When looking directly at this unit, the beam appears all to be the same color without seeing any color separation in the lenses. The IP 65 rating makes this unit perfect for outdoor weather or standard indoor use. Additionally the dual stand yoke allows the unit to be positioned on the floor or clamp mounted.



Specifications: 36 x 3 watt trichromatic RGB LEDs ■ Beam angle: 25° lens standard ■ Optional beam angle: 45 degree ■ Thermally cooled internally by heat sink case ■ Control: Sound, auto, master/slave and DMX ■ On-board LED display menu with 4 push buttons for settings ■ Multiple modes include: a DMX 3, 4, 5 or 6 channel modes, manual color settings, internal programs, master / slave using sound and auto speed settings ■ Maximum DMX Channel Mode: Ch1 - Master Dimmer, Ch2 - Red level, Ch3 - Green level, Ch4 - Blue Level, Ch5 - Macro, Ch6 - Strobe ■ DMX In/Out: 3-pin XLR connectors ■ Rating: IP 65 for outdoor use ■ Heavy duty, light weight die cast aluminum housing ■ Dual stand yoke with 1/2" clamp mounting holes, for hanging or floor standing ■ Power Input: Auto-ranging 100-240vAC, 50/60Hz ■ Power Consumption: 155w ■ Size: 9.5"x11"x7.25" ■ Weight: 7Kgs/15.4Lbs ■ Color: Black

ULTRALED TRICOLOR PAR 64

DL-PAR64TC18/B Black
DL-PAR64TC18/P Polished

Specifications: RGB color mixing with intensity and strobe effects ■ 18 high power trichromatic 3 x 1w LEDs ■ 18 red, 18 green, 18 blue ■ Beam angle: 25 degrees ■ 7 Operating modes: DMX, Static Color, Color Changing, Color Fading, Auto Run, Sound Active, Master/Slave ■ 6 DMX channels: Ch1 - Master Dimmer, Ch2 - Red level, Ch3 - Green level, Ch4 - Blue Level, Ch5 - Macro, Ch6 - Strobe ■ Static color mode with 7 colors: red, green, blue, purple, yellow, cyan and white ■ Three frame holding clips plus 4th spring loaded clip with 10" filter frame ■ DMX input/output via 3 pin XLR ■ Digital LED display menu for settings ■ Fuse protection ■ Dual yoke for floor or hang mounting ■ Clamp mounting hole: 1/2 inch ■ Aluminum housing ■ Power Consumption: 60 watts ■ Power: 110-240vAC, 50-60Hz ■ Size: 13"x11.25"x10.5" ■ Weight: 3.5Kgs/7.7Lbs

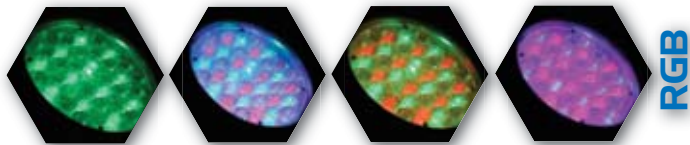

RGB

LED PAR46 RGB DMX

DL-PAR46RGB/B Black
DL-PAR46RGB/W White

The PAR46 LED RGB color mixing fixture can produce an unlimited array of colors. Fade from one color to the next, from a saturated RED to BLUE to GREEN and any color in between. This compact fixture offers the features of more expensive LED lights in an economical stylish plastic housing.



Specifications: Medium power RGB LED color mixing fixture using 90 large LEDs ■ 30 Red LEDs, 30 Blue LEDs, 30 Green LEDs ■ Control using DMX512 via 3 pin XLR connectors ■ Dip switch DMX addressing ■ 6 Channels of DMX ■ Standalone audio control using built microphone or internal modes ■ Adjustable input audio level ■ Fast action strobing or slow transition fades ■ Includes two plastic lenses: narrow beam clear & medium flood frosted ■ Adjustable U-bracket yoke with 1/2" clamp mount hole ■ Power: 100-240vAC50/60Hz ■ Current Draw: 0.2 Amps ■ Size: 7"x6.75"x6.75" ■ Weight: 0.91Kgs/2.02Lbs ■ Color: Black or White

ULTRALED DIGITAL PAR 64

DL-PAR64C183/B Black
DL-PAR64C183/P Polished

Specifications: RGB color mixing with intensity and strobe effects ■ 183 total ultra bright 10mm LEDs: 60 red, 60 green, 63 blue ■ Beam angle: 15 degrees ■ 7 Operating modes: DMX, Static Color, Color Changing, Color Fading, Auto Run, Sound Active, Master/Slave ■ 6 DMX channels: Ch1 - Master Dimmer, Ch2 - Red level, Ch3 - Green level, Ch4 - Blue Level, Ch5 - Macro, Ch6 - Strobe ■ Static color mode with 7 colors: red, green, blue, purple, yellow, cyan and white ■ Three frame holding clips plus 4th spring loaded clip with 10" filter frame ■ DMX input/output via 3 pin XLR ■ Digital LED display menu for settings ■ Fuse protection ■ Dual yoke for floor or hang mounting ■ Clamp mounting hole: 1/2 inch ■ Aluminum housing ■ Power Consumption: 30 watts ■ Power: 110-240vAC, 50-60Hz ■ Size: 13"x11.25"x10.5" ■ Weight: 2.3Kgs/5.1Lbs



ULTRALED SPOT

DL-LEDSPOTC55/B Black

Specifications: RGB color mixing with intensity and strobe effects ■ 55 total ultra bright 10mm LEDs: 18 red, 19 green, 18 blue ■ Beam angle: 10 degrees ■ Operating modes: DMX, Sound Active, Master/Slave ■ DMX512 using 6 channels ■ DMX input/output via 3 pin XLR ■ Dip switch for settings ■ Power Consumption: 8 watts ■ Power: 110-240vAC, 50-60Hz

■ Lightweight metal housing ■ Clamp mounting hole: 3/8 inch ■ Size: 4.53"x4.92"x5.71" ■ Weight: 0.8Kgs/1.8Lbs



ULTRALED PAR 38

DL-PAR38C75/B Black
DL-PAR38C75/P Polished

Specifications: RGB color mixing with intensity and strobe effects ■ 75 total ultra bright 10mm LEDs: 25 red, 25 green, 25 blue ■ Beam angle: 25 degrees ■ Operating modes: DMX, Sound Active, Master/Slave ■ DMX512 using 6 channels: Ch1 - Master Dimmer, Ch2 - Red level, Ch3 - Green level, Ch4 - Blue Level, Ch5 - Macro, Ch6 - Strobe ■ DMX input/output via 3 pin XLR ■ Dip switch for settings ■ Lightweight aluminum housing ■ Clamp mounting hole: 3/8 inch ■ Power Consumption: 13 watts ■ Power: 110-240vAC, 50-60Hz ■ Size: 7"x6.75"x6.5" ■ Weight: 1.2Kgs/2.65Lbs

UltraLED SERIES

PANEL SERIES

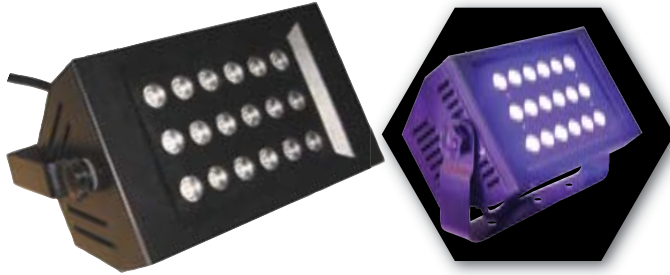

DL-PANEL2-18U UV Blacklight Wash

Specifications: UV LED light source with intensity and strobe effects ■ 18 ultra bright 1w UV LEDs at 400~410nm ■ Controllable as one panel ■ Operating modes: DMX, Manual Settings, Sound Active ■ Includes mounting bracket with 1/2 inch clamp hole ■ Beam angle: 30 degrees ■ DMX512 using 2 channels ■ DMX input/output via 3 pin XLR ■ Dip switch for settings ■ Power Consumption: 30 watts ■ Power: 110-240vAC, 50-60Hz ■ Size: 10.24"x5.71"x5.2" ■ Weight: 2.6Kgs/5.72Lbs



DL-PANEL1-192U UV Blacklight Effect

Specifications: UV LED light source with intensity and strobe effects ■ 192 total ultra bright 5mm LEDs: 192 UV at 400~410nm ■ Controllable as one panel ■ Operating modes: DMX, Auto Run, Sound Active, Master/Slave ■ Includes mounting bracket with 1/2 inch clamp hole ■ Beam angle: 45 degrees ■ DMX512 using 3 channels ■ DMX input/output via 3 pin XLR ■ Dip switch for settings ■ IEC power input connector ■ Power Consumption: 26 watts ■ Power: 100-240vAC, 50-60Hz ■ Size: 15.25"x9.38"x3.25" ■ Weight: 2.5Kgs/5.5Lbs

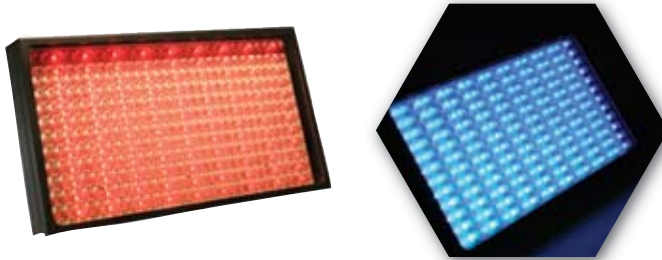

DL-PANEL1-336C RGB Effect

Specifications: RGB color mixing LED light source with intensity and strobe effects ■ 336 total ultra bright 10mm LEDs: 108 red, 108 green, 120 blue ■ Controllable as one panel ■ Operating modes: DMX, Auto Run, Sound Active ■ Includes mounting bracket with 1/2 inch clamp hole ■ Beam angle: 25 degrees ■ DMX512 using 3 or 6 channels ■ DMX input/output via 3 pin XLR ■ Narrow body edge trim allows units to be close to each other ■ LED display menu for settings ■ Power Consumption: 40 watts ■ Power: 110-240vAC, 50-60Hz ■ Size: 15.13"x8.13"x4" ■ Weight: 3.64Kgs/8Lbs



DL-PANEL1-192W White Strobe

Specifications: White LED light source with intensity and strobe effects ■ 192 total ultra bright 5mm LEDs: 192 white ■ Long Life LED light source ■ Controllable as one panel ■ Operating modes: DMX, Auto Run, Sound Active, Master/Slave ■ Includes mounting bracket with 1/2 inch clamp hole ■ Beam angle: 45 degrees ■ DMX512 using 3 channels ■ DMX input/output via 3 pin XLR ■ Dip switch for settings ■ IEC power input connector ■ Power Consumption: 26 watts ■ Power: 100-240vAC, 50-60Hz ■ Size: 15.25"x9.38"x3.25" ■ Weight: 2.5Kgs/5.5Lbs

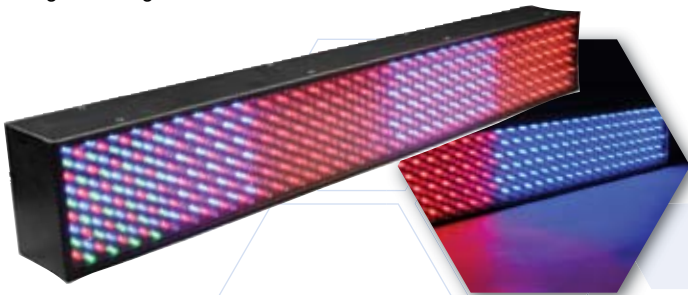

UltraLED Panel 8 Horizontal 1x8
DL-PANEL8CH

Specifications: 648 total 5mm ultra bright LEDs: 216 red, 216 green, 216 blue ■ 8 LED Segment blocks in 1 x 8 layout ■ Narrow body edge trim allows units to be close to each other ■ 3 DMX modes: 7 channels – panel as one group, 10 channels – panel divided into 2 groups, 28 channels – panel divided into 8 groups ■ Flash, dimming and strobe effects ■ Master/slave control ■ Sound active control ■ Built-in lighting programs and rainbow effects ■ 15° Beam angle ■ LCD display plus jog wheel for menu control ■ DMX In/Out via 3 Pin XLRs ■ Power consumption: 55 watts ■ Power: 90-240vAC, 50-60Hz ■ IEC power in and out connectors ■ Mounting bracket with 1/2 inch clamp hole ■ Two safety eyebolt hang points ■ Size: 31.63"x4.75"x6.25" ■ Weight: 4.77Kgs/10.5Lbs

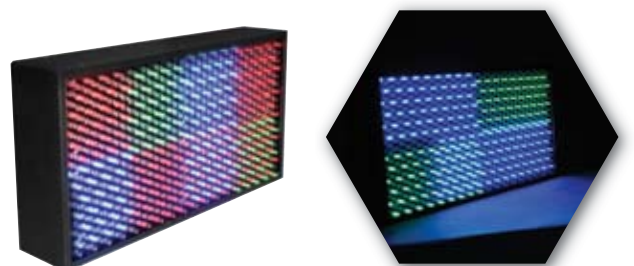

UltraLED Panel 8 Vertical 2x4
DL-PANEL8CV

Specifications: 648 total 5mm ultra bright LEDs: 216 red, 216 green, 216 blue ■ 8 LED Segment blocks in 2 x 4 layout ■ Narrow body edge trim allows units to be close to each other ■ 3 DMX modes: 7 channels – panel as one group, 10 channels – panel divided into 2 groups, 28 channels – panel divided into 8 groups ■ Flash, dimming and strobe effects ■ Master/slave control ■ Sound active control ■ Built-in lighting programs and rainbow effects ■ 15° Beam angle ■ LCD display plus jog wheel for menu control ■ DMX In/Out via 3 Pin XLRs ■ Power consumption: 55 watts ■ Power: 90-240vAC, 50-60Hz ■ IEC power in and out connectors ■ Mounting bracket with 1/2 inch clamp hole ■ Two safety eyebolt hang points ■ Size: 16.13"x8.5"x6.25" ■ Weight: 4.32Kgs/9.5Lbs

Specifications are subject to change without notice.

ULTRALED VISION MESH

The Vision Mesh is a graphic rendering modular system using SMD LED pixel and static scanning technology. It is composed of an assembly of multiple panels which can be locked together to form different shaped walls. VMesh is economical, easy to install, rugged and durable. Its versatility enables the use of this product for staging or other indoor applications where the effect of LED screen imagery and a semi-see through property is desired.

Overall features: Reduced mosaic effect ■ Even and Consistent light distribution ■ Large viewing angle: 120 degrees horizontally or vertically ■ Lightweight and easy to install ■ Compatible with DVI display – direct to DVI port ■ Single cable transmission ■ Standard network cabling using CAT5 ■ Signal transmission of up to 500 feet without degradation ■ 4-layer PCB design with single chip integrated circuit design ■ PC software controllable

To create a Vision Mesh wall, it is required to purchase multiple modules to create desired wall size configuration. Each system or wall will require the purchase of a minimum of one VMESHKIT package (DL-VMESHKIT), which includes software, a scan control box and one PCI card for the computer. All needed cables to connect the wall together are provided with each module. A cat5 cable must be extended from the computer to the scan control box located on one of the Vmesh modules. All Vmesh modules have a PSU mounted on them.

DL-VMESHMOD Individual Vision Mesh modules, 25.2 x 25.2 x 2.6 inches

Specifications: Signal input: 16p dual-roll D-Sub connector ■ Pitch: 40mm ■ Pixel composition: 5mm LEDs - 2 Red, 1 Green, 1 Blue ■ Cell resolution: 16 x 16 ■ Dot intensity (dot/m2): 625 ■ Luminance (cd/m2): 1300 ■ Optimal viewing distance: 150 to 200 feet ■ Frame change: 60 frames/second ■ Module power consumption: 75 watts peak ■ Average module power consumption: 40 watts ■ Module size: 25.2"x25.2"x2.6" ■ Module weight: 10Kgs/22Lbs ■ Hardware included: cross pins, eyebolts for hanging and wall mounting brackets ■ Power: 100-240vAC, 50-60hz

DL-VMESHKIT: Software, Receiving Vision scan controller box and Vision PCI/DVI card. The Vision PCI/DVI card can control up to 99 receiver cards.

Word of Life Center
Shreveport, Louisiana
Photo Credits: Chad Giddens

Minimum computer requirements: Windows 98, ME, 2000 or XP, Pentium 300Mhz, 1 Com port, Dual head video with DVI, one PCI slot

LED Light Tubes

The LED RGB light tubes represents the most advanced animated light tubes available today. By merging Red, Green, and Blue LEDs, they create different kinds of effects including solid color change, individual pixel color chases, gradual and fast transitions, gray scale color levels, and graphical illumination effects. LED light tubes can be used for decorative, architectural, entertainment and themed applications, indoors and outdoors. The combination of many tubes can be used as scenic elements on stages to produce spectacular and unique visual effects. Tubes may be placed in straight runs or to form a wall matrix. These tubes can be connected in a daisy chain format (linked from one to the other). Each tube has 5 pin XLR connectors for input and output of data and separate connectors for power in and out. There are two sizes available: 0.5 and 1 meter.



DL-TUBERGB10/D

1 meter tube - 144 LEDs

Specifications: Housing: Aluminum & Opaque anti-UV tube ■ 16.8 watt ■ 48 Red, 48 Green, 48 Blue LEDs ■ Use CT-TUBERGB Controller ■ DMX512 using 49 channels maximum ■ Rating: IP65 ■ Mounting clips included ■ Power: 100-240vAC 50/60hz ■ Size: 39.5"x2"x3.75" ■ Weight: 1.73Kgs/2.5Lbs

DL-TUBERGB05/D

0.5 meter tube - 72 LEDs

Specifications: Housing: Aluminum & Opaque anti-UV tube ■ 8.4 watt ■ 24 Red, 24 Green, 24 Blue LEDs ■ Use CT-TUBERGB Controller ■ DMX512 using 25 channels maximum ■ Rating: IP65 n Mounting clips included ■ Power: 100-240vAC 50/60hz ■ Size: 19.75"x2"x3.75" ■ Weight: 1.14Kgs/2.51Lbs

LED Tube Controller

CT-TUBERGB

The RGB tube controller offers many modes of operation. It can run stand alone with hundreds of internal pre-built programs, speed and fade settings. Custom programs may also be create and stored, or it can run using a PC. Operates up to 5000 meters of the RGB tubes. A controller is needed to address tubes for DMX operation.

Specifications: Modes: PC, Set-up, Step Play, Auto Play ■ Control up to 5000 meters ■ Smart Media Card slot for 64mb storage ■ Power: 9v-12vDC, includes 120vAC wall adaptor ■ Size: 7.25"x4"x2" ■ Weight: 0.6Kgs/1.3Lbs.

Built-In Controller Effects: Static Color - Red, Green, Yellow, Blue, Purple, Cyan, White ■ Slow Flow (unidirectional) ■ Slow Flow (bi-directional) ■ Roll Chase1 (rolling back and forth) ■ Roll Chase2 (scan back and forth) ■ Multi Color Chase (Rainbow) ■ Fast Flow1 ■ Fast Flow2 ■ Two Color Chase ■ Two Color Flow ■ Gray Scale Color Change ■ Dynamic Picture Effect

Techni-Lux



UltraLED RGB Mini Tube

DL-TUBEMINI/C



Mini LED Tube is a decorative color changing light emitting tube that can be used for cove, stage, ambient, and architectural applications where long linear runs are needed in a narrow space. It can also be used under cabinets, borders and wall shelves. It is very easy to install and control using DMX or its standalone modes. The tubes connect from one to the other in a string fashion. Its economical price makes it possible to be specified in large quantities.

Specifications: (per Mini Tube) RGB color mixing with dimming ■ 16.7 million colors ■ 45 total ultra bright 5mm LEDs: 15 red, 15 green, 15 blue ■ Tube Length: 300mm (11.81") ■ Tube Diameter: 30mm (1.18") ■ Beam angle: 85 x 40 degrees ■ Operating modes: DMX & Standalone ■ Control using DMX512 ■ Input/output via 4 pin XLR ■ Dip switch for settings ■ Lightweight plastic housing ■ Mounting clips included ■ Power Consumption: minimum 1.4 watts, maximum 4.8 watts (all LEDs on) ■ Power: 12vDC ■ Size: 11.93"x1.85"x1.84" ■ Weight: .23Kgs/.5Lbs

UltraLED BAR 45

DL-BAR1CWA45

This high power RGBWA color mixing bar features 45 LEDs for medium to long throw applications. Each LED is independently controllable by DMX, giving the designer enormous creative freedom. Using the USB port and a standard PC computer, one can update the software & customize the internal color/effect library.

Specifications: Light source: 45 x 1.2w / 400mA LEDs ■ 9 LEDs of each - Red, Green, Blue, White, Amber ■ Fast 400Hz refresh frequency for video friendly flicker-free operation ■ Beam angle: 15° installed standard ■ Beam angle options: 10°, 25°, 35° and 45° ■ Multiple operation modes: Programs, Auto master/slave, Sound or DMX ■ 50 changeable preset colors ■ 12 editable programs ■ Dimming from 0 to 100% ■ Strobe effect 1 – 30 fps ■ DMX Channels: 3, 7, 21, 46, or 47 ■ DMX Connectors: XLR 5 Pin in/out ■ Thermal management to ensure long life of LEDs ■ Automatic fan speed adjustment ■ Control Panel: 4 push buttons & blue LCD display of 16 x 2 digits ■ USB port for updating firmware, programs & color presets ■ Power failure memory ■ Power in and out daisy chain ■ Adjustable floor stand & mounting bracket ■ Power consumption: 90W ■ Power Input: 100-240vAC 50/60Hz ■ Size: 20.1"x5.82"x9.25" ■ Weight: 8.5Kgs/18.7Lbs

UltraLED DMX Color Bars

DL-BAR10C252

This is the innovative UltraLED Series Color Bar, which can be used for the Stage, Theatre, Studio and Clubs is great for back wall and cove lighting where a medium power LED source is required. The user can operate the unit "stand-alone" with built-in programs or connect to any standard DMX controller directly for easy controlling.

Specifications: RGB color mixing with intensity and strobe effects ■ 252 ultra bright 10mm LEDs: 48 red, 108 green, 96 blue ■ Long Life LED light source ■ Controllable as one bar or in 3 segments of 1/3 sections ■ Operating modes: DMX, Static Color, Color Changing, Color Fading, Auto Run, Sound Active, Master/Slave ■ Floor standing with side brackets or hanging ■ Beam angle: approximately 30 degrees ■ DMX512 using 12 channels maximum ■ DMX input/output via 3 pin XLR ■ Dip switch for settings ■ Power Consumption: 30 watts ■ Power: 100-230vAC, 50-60Hz ■ Size: 41.5"x2.5"x3.5" ■ Weight: 2.72Kgs/6Lbs

UltraLED SERIES

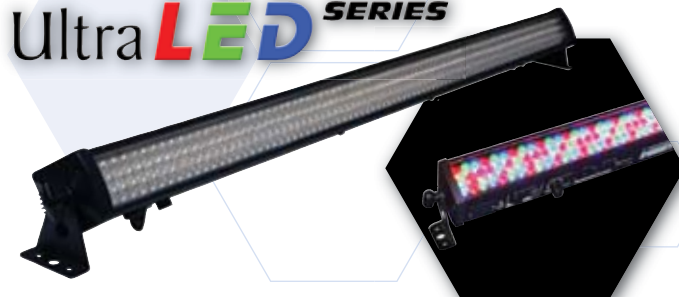

Specifications: RGB color mixing with intensity and strobe effects ■ 24 tricolor 3w LEDs ■ Long Life LED light source ■ 1450 lux at 3 meters output ■ Controllable as one bar or in 8 segments of 3 tricolor leds ■ Operating modes: DMX, Static Color, Color Changing, Color Fading, Auto Run, Sound Active, Master/Slave ■ Floor standing with side brackets or hanging with rear bracket from optional clamp ■ Beam angle: approx. 25 degrees ■ DMX512 mode selections: 6, 9, 15, 24, or 27 channels for maximum control of sections ■ DMX input/output via 3 pin XLR ■ Digital Blue-lit display plus 4 push buttons ■ Power Consumption: 100 watts ■ Power: 100-230vAC, 50-60Hz ■ Size: 41"x5.9"x6.3" ■ Weight: 6Kgs/13.2Lbs ■ **Optional Lenses: 40**

UltraLED SERIES

TUBE POWER SUPPLY/CONTROL UNITS

All RGB Tubes and Mini Tube require a PSU. There are 2 PSU models to choose from, a 2 output or a 6 output unit. Each output can power up to: (20) DL-TUBEMINI/C.



DL-TUBE/PSU2 Specifications: Power Supply Unit – 2 outputs ■ Power in: 100-240vAC, 50-60hz ■ Output: 12vDC ■ Size: 14.5"x8.5"x3.5" ■ Weight: 2.3Kgs/5Lbs

DL-TUBE/PSU6 Specifications: Power Supply Unit – 6 outputs ■ Power in: 100-240vAC, 50-60hz ■ Output: 12vDC ■ Size: 18.5"x8.5"x3.5" ■ Weight: 4.55Kgs/10Lbs

UltraLED SERIES



DL-BAR10TC24

The DMX Tricolor Bar is a high power UltraLED Series Color Bar using 24 x 3w Tricolor LED technology. Tricolor LED units reduce color shadows and produce a more even color beam over traditional RGB independent LED sources. The DMX Tricolor Bar is ideal for applications in Stage, Theatre, Studio and Clubs. It is also great for back wall and cove lighting where a reliable high power LED source is required. The user can operate the unit "stand-alone" with built-in programs or connect to any standard DMX controller directly for easy controlling. Features power in and out using standard computer IEC connectors for continuous runs of 6 units in a single row of power. Setup is easily done using a digital display and 4 push buttons, no dip switches!



ARCHIBAR 150 DL-ARCHIBAR/C

Archibar 150 is a powerful IP 67 wash led light fixture. The compact Archibar 150 is made in aluminium and is equipped with 16 group (rgbw) each one with 4 units of 3W Luxeon Rebel led's. The optics, realized in special material, allow brilliant light and a very homogeneous beam. Standard optics are 25°. Optional wide 40° beam lens kit is available (sold separately).

Specifications: (LED Luxeon Rebel) 16 group (RGBW) with four units of 3W Led's ■ 25mm lenses standard beam (25°) ■ Tilt: 120° ■ RS-485; opto-couplet input interface ■ USITT DMX 512 - 9 channels ■ Internal microswitches ■ Internal preset with master/slave function ■ IP 67 fixture, main power and DMX cable connections ■ Switching power supply (universal main voltage) ■ Power consumption: 180 watts ■ Power: 100-240vAC, 50-60Hz ■ 1A @ 230V ■ DMX Channels: ch1 = RED, ch2 = GREEN, ch3 = BLUE, ch4 = WHITE, ch5 = STROBECH, ch6 = DIMMER, ch7 = LED FADE TIME, ch8 = RAINBOW, ch9 = WHITE BALANCED ■ Size: 39.56"x10.04" ■ Weight: 7Kgs/15.43Lbs

Optional beam lens kits: wide 40° beam

ARCHILED DL-ARCHILED150/C

The first in the ArchiLED Series Control panel with touch control technology, the innovative intelligent capacitive sensor. No mechanical switch and indoor outdoor use.



Specifications: CREE® XLamp® XR LED ■ Four color system – Red, Green, Blue Hi-Power 3W LEDs and 8 bit linear color correction with AMBER ■ 14 RED 3W LEDs - total 770 lumens ■ 12 GREEN 3W LEDs - total 840 lumens ■ 12 BLUE

3W LEDs - total 300 lumens ■ 8 AMBER 1W LEDs – total 340 lumens ■ Total output of 2250 lumens ■ Standard 23° medium beam angle with 22mm lenses ■ Manual TILT up to 210° of head rotation ■ IP 67 with cable connection included ■ Control Output Standard interface: RS-485; opto-coupled input ■ Protocol: USITT DMX 512 using 10 channels ■ IP 67 DMX connectors ■ Aluminum and Steel body ■ Touch control panel with display and dynamic menus ■ 16 bit led dimming for precise color mixing ■ Master/slave function ■ 8 internal presets with variable speed ■ DMX Channels: ch1 = RED, ch2 = GREEN, ch3 = BLUE, ch4 = AMBER, ch5 = AUX, ch6 = DIMMER, ch7 = STROBE/STROBE+RAINBOW, ch8 = FADE SPEED, ch9 = MACRO, ch10 = WHITE BALANCE ■ Switching power supply (universal main voltage) ■ Power: 100-240vAC, 50-60Hz ■ Power consumption: 150 watts ■ Size: 13.5"x12.9"x4.9" ■ Weight: 7.7Kgs/16.98Lbs

Optional beam lens kits: narrow beam 10°, wide beam 45°, and elliptical 15°x90° horizontal or vertical

Additional accessories available: barn doors

DL-ARCHILED150/W: White LED version with barn doors

NANOLED DL-NANOLED/C

Powerful, dynamic and glamour all in a compact package define the NANO LED. This stylish unit produces unlimited color mixing using high output LEDs. Applications include club lighting, retail, shopping centers, party events, architectural accenting, ambient and up lighting.



Specifications: CREE® XLamp® XR LED ■ Three color RGB mixing system using high power 3W LEDs ■ 4 RED 3W LEDs - total 240 lumens ■ 5 GREEN 3W LEDs - total 440 lumen ■ 5 BLUE 3W LEDs - total 150 lumen ■ Total output: 830 lumens ■ Standard output beam of 23° medium using 22mm lenses ■ Optional: narrow beam lens (10°) ■ Motorized Pan: 350° (1.5 sec. - 16 bit) ■ Motorized Tilt: 243° (1.1 sec. - 16 bit) ■ Standard interface: RS-485; opto-coupled input ■ Protocol: USITT DMX 512 - 12 channels 3 pin connection inside connections for permanent installations ■ DMX Channels: ch1 = RED, ch2 = GREEN, ch3 = BLUE, ch4 = STROBE/RAINBOW, ch5 = PAN COARSE, ch6 = PAN FINE, ch7 = TILT COARSE, ch8 = TILT FINE, ch9 = DIMMER, ch10 = MOTOR SPEED, ch11 = FADE SPEED, ch12 = RESET ■ Control panel with dynamic menu (built-in microprocessor with LED display and buttons) ■ 16 bit led dimming for precise color mixing ■ Master/slave function ■ 8 internal presets with variable speed ■ Aluminum and Plastic body ■ Switching power supply (universal main voltage) ■ Power consumption: 60 watts ■ Power: 100-240vAC, 50-60Hz ■ Size: 10.8"x9.7"x8.7" ■ Weight: 4.3Kgs/9.5Lbs

D-COLOR DL-DCOLOR

The D-Color represents the latest technologies in moving head motion: infinite positions plus a high power LED color wash system. Its unique movement capabilities sets it apart from all other existing lighting fixtures. The D-Color adds a new dimension in lighting movement and ergonomic design.



Specifications: CREE® XLamp® XR LED ■ Four color system – Red, Green, Blue Hi-Power 3W LEDs and 8 bit linear color correction with AMBER ■ 8 RED 3W LEDs - total 480 lumens ■ 8 GREEN 3W LEDs - total 640 lumens ■ 8 BLUE 3W LEDs - total 240 lumens ■ 4 AMBER 1W LEDs - total 180 lumens ■ Output total: 1540 lumens ■ Standard output beam of 23° medium using 22mm lenses ■ Optional: narrow beam lens (10°) ■ Motorized Pan: 540° (2.5 sec. - 16 bit) ■ Motorized Tilt 1: 170° (2.5 sec. - 16 bit) ■ Motorized Tilt 2: 170° (2.5 sec. - 16 bit) ■ Standard interface: RS-485; opto-coupled input. ■ Protocol: USITT DMX 512 - 15 channels ■ 3 pin XLR connectors (male/female) ■ Control panel with dynamic menu (built-in microprocessor with LED display and buttons) ■ 16 bit led dimming for precise color mixing ■ Master/slave function ■ Internal presets with variable speed ■ Music sync by internal microphone ■ DMX Channels (12 or 15): ch1 = RED, ch2 = GREEN, ch3 = BLUE, ch4 = AMBER, ch5 = PAN COARSE, ch6 = PAN FINE*, ch7 = TILT COARSE, ch8 = TILT FINE*, ch9 = TILT2 COARSE, ch10 = TILT2, ch11 = DIMMER, ch12 = FADE SPEED, ch13 = MOTOR SPEED, ch14 = STROBE/RAINBOW, ch15 = RESET ■ Switching power supply (universal main voltage) ■ Power consumption: 110 watts ■ Power: 100-240vAC, 50-60Hz ■ Size: 21.5"x16.5"x12.9" ■ Weight: 9.5Kgs/21Lbs



CE



DL-UWLED36C-15

UNDERWATER LED 36 POWER RGB

- DL-UWLED36C-15
- DL-UWLED36C-140
- DL-UWLED36C-33x18

This powerful color changing underwater fixture was designed for fountains and all other applications where a fixture is needed to operate in water at a low voltage. It uses 36 high power LEDs as its light source. Its special stainless steel housing and support bracket enables the LED light output to be mounted in water, aimed and tightened down to point in any direction. With the new LED RGB technology and any DMX controller it is possible to generate a wide range of colors and dramatic scenes. Using this fixture significantly reduces the heat and power consumption typically associated with traditional incandescent and halogen color changing systems. It draws a maximum of 57 watts only when all three RGB LEDs are on full. Furthermore, these LED fixtures help cut maintenance lamp changes, and downtime by providing extensive average life hours. Warrantied for 2 years.

Specifications: RGB color mixing system using 36 1.2w PHILIPS Lumileds LUXEON®LEDs ■ Typical throw distance: 3 to 35 feet ■ DMX addressable using DLC900 setting device ■ Control: DMX 512 ■ 5 DMX Channels: Ch1-Red, Ch2-Green, Ch3-Blue, Ch4-Strobe, Ch5-Macros ■ Power: 12v AC ■ Power consumption: 57 watts ■ Input cable: 5 conductor x 13 feet ■ Stainless steel AISI 316 housing with support hardware and glass lens ■ IP Rating: IP68 ■ Size: 9"x9"x9" ■ Weight: 3.18Kgs/7Lbs

Available in three output beams: narrow 15 degree, medium oval 33x18 degrees, and a very wide 140 degree

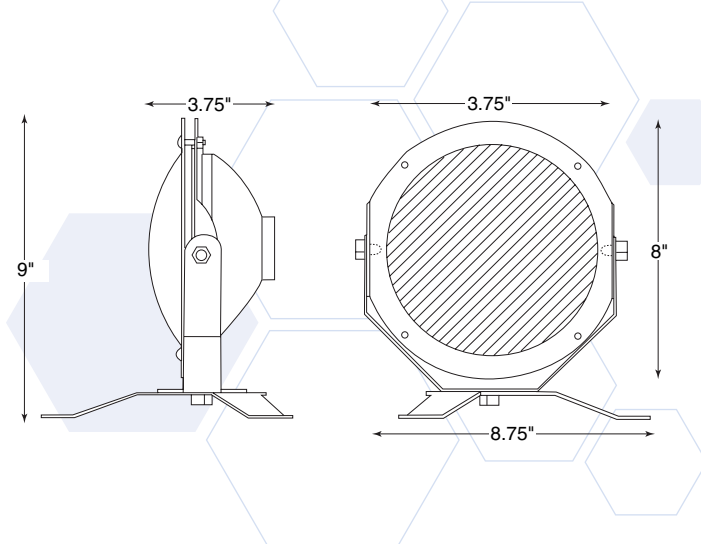

LUXEON® and the Logo are trademarks of PHILIPS Lumileds Lighting Company.



CE



DL-UWLED18C-140

UNDERWATER LED 18 PLUS RGB

- DL-UWLED18C-15
- DL-UWLED18C-140
- DL-UWLED18C-33x18

The Underwater LED Plus 18 fixture compliments the underwater range, when it is not necessary to have the higher output of the Underwater LED POWER 36 version. It is designed for fountains and all other applications where a fixture is needed to operate in water at a low voltage. It uses 18 high power LEDs as its light source. Its special stainless steel housing and support bracket enables the LED light output to be mounted in water, aimed and tightened down to point in any direction. With the new LED RGB technology and any DMX controller it is possible to generate a wide range of colors and dramatic scenes. Using this fixture significantly reduces the heat and power consumption typically associated with traditional incandescent and halogen color changing systems. It draws a maximum of 44 watts only when all three RGB LEDs are on full. Furthermore, these LED fixtures help cut maintenance lamp changes, and downtime by providing extensive average life hours. Warrantied for 2 years.

Specifications: RGB color mixing system using 18 1.2w PHILIPS Lumileds LUXEON®LEDs ■ Typical throw distance: 3 to 30 feet ■ DMX addressable using DLC900 setting device ■ Control: DMX 512 ■ 5 DMX Channels: Ch1-Red, Ch2-Green, Ch3-Blue, Ch4-Strobe, Ch5-Macros ■ Power: 12v AC ■ Power consumption: 44 watts ■ Input cable: 5 conductor x 13 feet ■ Stainless steel AISI 316 housing and support hardware and glass lens ■ IP Rating: IP68 ■ Size: 9"x9"x9" ■ Weight: 2.95Kgs/6.5Lbs

Available in three output beams: narrow 15 degree, medium oval 33x18 degrees, and a very wide 140 degree



DL-UWLED36C-140

Specifications are subject to change without notice.

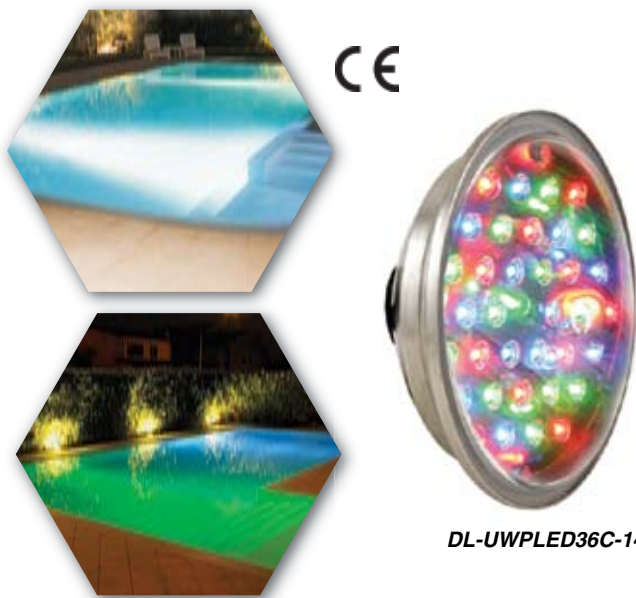

DL-UWPLED36C-140



DL-UWPLED18C-140

SWIMMING POOL LED 36 POWER RGB
DL-UWPLED36C-140

This powerful color changing underwater fixture was specifically designed for swimming pools where a fixture is needed to operate in water at a low voltage. It uses 36 high power LEDs as its light source. It will fit in most standard swimming pool light niches (Par 56 size enclosure). With the new LED RGB technology and any DMX controller it is possible to generate a wide range of colors and dramatic scenes. An optional wireless remote is available instead of DMX control. Using this fixture significantly reduces the heat and power consumption typically associated with traditional incandescent and halogen color changing systems. It draws a maximum of 57 watts only when all three RGB LEDs are on full. Furthermore, these LED fixtures help cut maintenance lamp changes, and downtime by providing extensive average life hours. Warrantied for 2 years.

Specifications: RGB color mixing system using 36 1.2w PHILIPS Lumileds LUXEON®LEDs ■ DMX addressable using DLC900 setting device ■ Control: DMX 512 ■ 5 DMX Channels: Ch1-Red, Ch2-Green, Ch3-Blue, Ch4-Strobe, Ch5-Macros ■ Power: 12v AC ■ Power consumption: 57 watts ■ Input cable: 5 conductor x 13 feet ■ Stainless steel AISI 316 housing and glass lens ■ Fits in standard 56 Par ■ Size: 6.97"x6.97"x3.35" ■ Weight: 1Kgs/2.2Lbs

Available Options: *Wireless remote in place of DMX, Underwater Niche, Single color options - White*

SWIMMING POOL LED 18 PLUS RGB
DL-UWPLED18C-140
DL-UWPLED18C-33x18

The Underwater LED Plus 18 fixture compliments the underwater range, when it is not necessary to have the higher output of the Swimming Pool LED POWER 36 version. It is designed for swimming pools where a fixture is needed to operate in water at a low voltage. It uses 18 high power LEDs as its light source. It will fit in most standard swimming pool light niches (Par 56 size enclosure). With the new LED RGB technology and any DMX controller it is possible to generate a wide range of colors and dramatic scenes. An optional wireless remote is available instead of DMX control. Using this fixture significantly reduces the heat and power consumption typically associated with traditional incandescent and halogen color changing systems. It draws a maximum of 44 watts only when all three RGB LEDs are on full. Furthermore, these LED fixtures help cut maintenance lamp changes, and downtime by providing extensive average life hours. Warrantied for 2 years.

Specifications: RGB color mixing system using 18 1.2w PHILIPS Lumileds LUXEON®LEDs ■ DMX addressable using DLC900 setting device ■ Control: DMX 512 ■ 5 DMX Channels: Ch1-Red, Ch2-Green, Ch3-Blue, Ch4-Strobe, Ch5-Macros ■ Power: 12v AC ■ Power consumption: 44 watts ■ Input cable: 5 conductor x 13 feet ■ Stainless steel AISI 316 housing and glass lens ■ IP Rating: IP68 ■ Fits in standard 56 Par ■ Dimensions: 6.97"x6.97"x3.35" ■ Weight: 1Kgs/2.2Lbs

Available Options: *Two lenses - very wide 140 degree and medium oval 33x18 degrees, Wireless remote in place of DMX, Underwater Niche, Single color options - White, Blue*

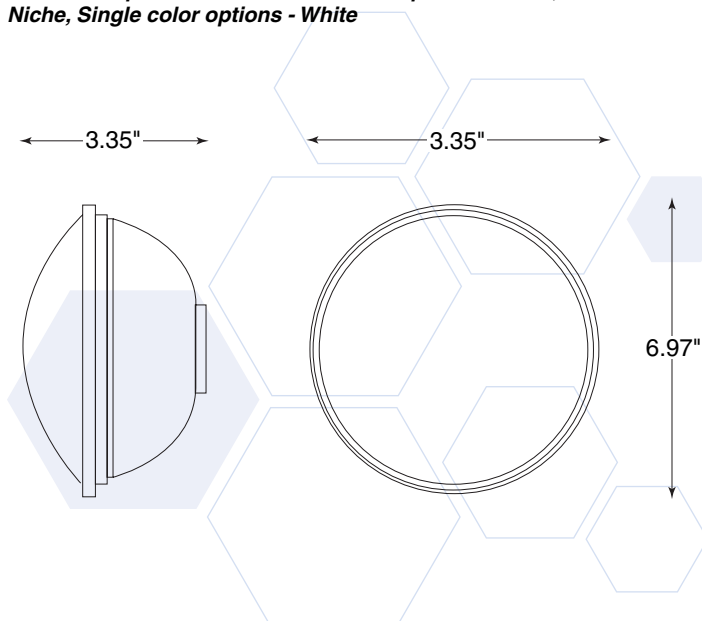

DLC 900
CT-DLC900

DLC900 is a multifunctional handheld controller with following features:

- Remote control of the devices connected via DMX
- Automatic identification of connected devices and DMX addressing
- Access to fixture menu settings for configuration purposes
- Device reprogramming: download of software updates to devices connected via DMX
- Save updates on multimedia card
- DMX output: possibility to configure and send a DMX signals of all 512 channels
- DMX Tester: control of DMX input values, up to 512 channels

Specifications: Size: 4.3"x2.6"x1.1" ■ Weight: 0.1Kgs/.22Lbs

LUXEON® and the Logo are trademarks of PHILIPS Lumileds Lighting Company.

PALCO 5 FULL COLOR

The Palco 5 Full Color has been designed in order to host 105 LEDs in a matrix of 35 lenses, each with a maximum power of 9 Watts, enabling a very compact unit to obtain an impressively bright and uniform output. Using Rebel LEDs and a new combining lens system, each of the three LED clusters are collected into one lens output. The red, green and blue LEDs better mix together and thus form a uniform, coherent and powerful light source point. The desirable light diffusion and spread is ensured by a choice of three different lenses that can be fitted: narrow, medium and wide. The Palco 5 Full Color can generate powerful light beams, with exceptionally even color on the illuminated surfaces while eliminating any colored shadow defects. Color uniformity is also achieved when viewing the fixture's LED matrix directly from the front. Visually it looks like the entire front panel is changing to your selected color. Palco 5 Full Color exceeds the already remarkable standards of the other units in the Palco fixture range, enabling to illuminate and color even larger areas while still reaching far distances. The already proven experience gained in Palco 3 & 5 fixtures are taken to yet a higher level of technology, making it even more resistant and tolerant to weather conditions.

DL-PALCO5TC

FULL COLOR VERSION – Light source: 35 Rebel Blue LEDs 3W, 35 Rebel Green LEDs - 3W, 35 Rebel Red LEDs 1.5W ■ Luminous flux 5,500 Lumens ■ Color temperature: 6,500 °K (variable)

DL-PALCO5TW

FULL WHITE VERSION – Light source: 70 White LEDs - 3W, 35 Amber LEDs - 2W ■ Luminous flux 12.000 Lumens ■ Color temperature: 2,000 - 6,700 °K (variable)

Specifications: LEDs expected life: 50,000 hours at maximum power ■ Interchangeable lenses: Narrow, Medium, Wide (choice of one included) ■ 8 DMX Channels: 1-Strobe/Shutter, 2-Dimmer, 3-Red, 4-Green, 5-Blue, 6-CTC, 7-Macros, 8-Color Mode ■ Opto-isolated DMX 512 input signal ■ DMX In/Out: 5 Pin XLR ■ Wireless DMX interface as standard ■ Outdoor antenna and extension cable as standard ■ Interface LED 10 digit display & 3 buttons ■ Internal Microcomputer Function menu (software updatable via DMX) ■ Pan +/- 45° - manually positioned ■ Tilt +15° / -75° - manually positioned ■ Insulation rating: IP 55 ■ Power: auto ranging 90-270vAC 50/60Hz ■ Consumption: 260W ■ Size: 16.73"x14.76"x9.02" ■ Weight: 13.5Kgs/29.7Lbs

PALCO FEATURES**Interchangeable Lenses**

Four Interchangeable lenses (8°, 25°, 40°, elliptical 10° x 22°) at various distances from the area being illuminated

Color & Color Temperature

Using a matrix of red, green and blue high power LEDs, additive color mixing is endless, from rich saturated to the coolest colors. Color temperature of the unit is 5500 kelvin and may be varied linearly.

Control & Menu

All functions are controllable via DMX using 8 channels. The 10 digit digital display allows for DMX addressing and all fixture settings.

Silent Operation

Totally silent, it does not use any type of forced ventilation. Palco is completely convection cooled by a rear heat sink. An electronic self-regulating internal temperature system ensures proper continuous operation even in extreme conditions.

Stand-Alone Operation

Completely programmable and operational without using any external controller. Can operate in master/slave mode with 1 master and 29 slaves. Independent programming of each unit is also possible. On-board weekly clock (7 day, 24 hour) function of 48 events. Clock playback scenes can occur gradually or instantly.

Installation

Palco has unique and stylish lines that enable it to discreetly fit into the surroundings and harmoniously adapt to the architectural elements which need to be lit. Palco may be floor or wall mounted by means of four screw holes on its base. It may also be flown from trussing using the included Fast-Lock pipe clamp. Once mounted, the head may be positioned by panning +/- 45 degrees, and tilted +15/-70 degrees.

**PALCO 5**

**DL-PALCO5-8 DL-PALCO5-25
DL-PALCO5-40**

Palco 5, one of the most powerful color changing LED fixtures in SGM range, is wireless DMX and can recognize transmission signals with a radius of over 500 meters (1,640 feet). Without connector cables, the Palco 5 becomes an even more versatile unit with increased positioning possibilities, leaving more space for lighting ideas and projects.

Specifications: LED RGB additive color mixing ■ 12 K2 Blue 4.5w LEDs ■ 24 K2 Green 4.5w LEDs ■ 13 Luxeon Red 4.5w LEDs ■ Luminous flux: 4,500 Lumens ■ Color temperature: 6,500°K (variable) ■ Average LED life: 50,000 hours at maximum power ■ Interchangeable lenses: 8°, 25°, 40°, Elliptical 10 x 22° (comes with choice of one) ■ 8 DMX Channels: 1-Strobe/Shutter, 2-Dimmer, 3-Red, 4-Green, 5-Blue, 6-CTC, 7-Macros, 8-Color Mode ■ Control via stand-alone, DMX or IR optional remote ■ Wireless DMX interface with outdoor antenna and extension cable included ■ Interface LED 10 digit display & 3 buttons ■ Internal Microcomputer Function menu (software updatable via DMX) ■ Pan +/- 45° - manually positioned ■ Tilt +15° / -75° - manually positioned ■ Mounting clamp included ■ Insulation rating: IP 55 ■ Power Consumption: 300 watts ■ Power: auto ranging 90-270vAC, 50/60Hz ■ Insulation rating: IP 65 ■ Size: 16.73"x14.76"x9.02" ■ Weight: 13.5Kgs/29.7Lbs

ADVANTAGES OF LEDs

The use of LED technology offers numerous advantages:

- LEDs generate light that does not emit ultraviolet rays (which are potentially dangerous) nor infrared rays, thus preventing heat and reducing damage to the objects being illuminated.
- Electricity consumption is considerably lower than that of conventional light sources, and directly proportional to the intensity of the light emitted. LEDs high efficiency therefore result in a lower impact on the environment.
- LEDs operation life is approximately 100,000 hours at full power, with no noticeable variation in the quality of the light emitted; fixture maintenance costs are therefore extremely low.

Specifications are subject to change without notice.



PALCO 3 MOBILE
DL-PALCO3M-X (X = Lens beam angle)

PALCO 3 MOBILE includes all the features of PALCO: silent operation, efficient power consumption, high color rendering, exclusive design and extremely compact lines - plus the possibility of being positioned as required, thanks to its pan and tilt movement. PALCO 3 MOBILE is fitted with absolute encoders so when reset doesn't run any repositioning procedure, it goes immediately to the required position. If accidentally moved, it restores the position and when switched off, a special mechanism enables to block the motor in the current position. Silent operation is guaranteed. PALCO MOBILE's qualities make it the right choice for replacing Halogen color changers with pan and tilt movement in all television and theater applications.

CODE	DESCRIPTION
DL-PALCO3M-40	Palco 3 Mobile LED Fixture - 40° Lens - no plug
DL-PALCO3M-25	Palco 3 Mobile LED Fixture - 25° Lens - no plug
DL-PALCO3M-8	Palco 3 Mobile LED Fixture - 8° Lens - no plug

Specifications: LED color mixing RGB additive ■ 7 Luxeon 3W Blue LEDs ■ 18 Luxeon 3W Green LEDs ■ 24 Luxeon 1W Red LEDs ■ Luminosity (white) 2,800 Lumens ■ Power Consumption 160w ■ Color temperature: 5,500°K (variable) ■ Interchangeable lenses: 8°, 25°, 40°, Elliptical 10 x 22° (comes with choice of one) ■ LEDs average life: 100,000 hours ■ Power: auto ranging 90-270vAC-50/60Hz ■ 13 DMX Channels: 1-Strobe/Shutter, 2-Dimmer 3-Red, 4-Green, 5-Blue, 6-CTC, 7-Macros, 8- Color Mode, 9-Pan High Bit, 10-PanLow Bit, 11-Tilt High Bit, 12-Tilt Low Bit, 13-Motor Speed ■ Interface LED 10 digit display & 3 buttons ■ Internal Microcomputer Function Menu (software updatable via DMX) ■ Motorized Pan 0°- 305° ■ Motorized Tilt 0°- 93° ■ Insulation rating: IP 33 ■ Size: 19.1"x10.83"x9.02" ■ Weight: 15.5Kgs/34.2Lbs

PALCO 3
DL-PALCO3-X (X = Lens beam angle)

The Palco is a groundbreaking color-changing fixture for indoor and outdoor applications, which uses as its light source 49 high-power Luxeon LEDs. Palco creates an evenly diffused light beam, ideal for illuminating large areas. It has full DMX 512 control of all its main characteristics: luminous intensity, RGB color mixing, color temperature correction. The exclusive design, extremely compact lines and protection to IP65 make the Palco ideal for either permanent or temporary installation in a wide range of applications: monuments, buildings, stages, houses of worship, museums, art galleries, libraries, shopping malls, store window displays. Palco is also perfect for dynamically coloring backdrops and scenery in theatres, television and photography studios. Palco comes in three versions: Palco 3, Palco 3 White and Palco 3 Mobile

Specifications: LED color mixing RGB additive ■ 3 watt LED ■ 7 Luxeon Blue LEDs ■ 18 Luxeon Green LEDs ■ 24 Luxeon Red LEDs ■ Luminosity (white) 2,800 Lumens ■ Luminous power 100w ■ Power Consumption 130w ■ Color temperature: 5,500°K (variable) ■ Interchangeable lenses: 8°, 25°, 40°, Elliptical 10 x 22° (comes with choice of one) ■ LEDs average life: 100,000 hours ■ Power: auto ranging 90-270vAC-50/60Hz ■ 8 DMX Channels: 1-Strobe/Shutter, 2-Dimmer, 3-Red, 4-Green, 5-Blue, 6-CTC, 7-Macros, 8-Color Mode ■ Interface LED 10 digit display & 3 buttons ■ Internal Microcomputer Function menu (software updatable via DMX) ■ Pan +/- 45° - manually positioned ■ Tilt +15° / -70° - manually positioned ■ Insulation rating: IP 65 ■ Size: (HxWxD) 16.73"x14.76"x9.02" ■ Weight: 13.5Kgs/29.7Lbs



US Grant Hotel, San Diego CA



PALCO 3 WHITE
DL-PALCO3W-X (X = Lens beam angle)

LED lighting has become even more specialized with Palco 3 White Led. Thanks to this ground-breaking fixture, fitted with 7 Luxeon amber LEDs and 42 Luxeon white LEDs, it's now possible to accurately recreate the fluctuation and nuances of natural daylight. A valuable tool for any lighting designer who wants to reproduce sophisticated white light effects for indoor and outdoor applications, Palco 3 White LED is able to match any color temperatures, from the warmest to the coolest white, between 3,000°K and 10,000°K, by balancing the intensity of the LED groupings to the required levels.

This fixture is a combination of SGM high-tech expertise and all the typical features of the Palco 3, including the exceptional design and extraordinary luminosity. For optimum installation flexibility, the unit's head can be removed from the rest of the body to allow for industry standard mounting.

Specifications: 7 Luxeon 3W Amber LEDs ■ 42 Luxeon 3W White LEDs ■ Luminosity 3,000 Lumens ■ Power Consumption 150w ■ Color temperature: 3,000-10,000°K (variable) ■ No UV - Ultraviolet radiation ■ No IR - Infrared heat ■ Interchangeable lenses: 8°, 25°, 40°, Elliptical 10 x 22° vertical, Elliptical 10 x 22° horizontal ■ LEDs average life: 100,000 hours ■ Power: auto ranging 90-270vAC-50/60Hz ■ 4 DMX Channels: 1-Strobe/Shutter, 2-Dimmer, 3-White, 4-Amber ■ Interface LED 10 digit display & 3 buttons ■ Manual Fixed Pan +/- 45° on base ■ Manual Fixed Tilt +15°, -70° on base ■ Insulation rating: IP 65 ■ Size: 16.73"x14.76"x9.02" ■ Weight: 13.5Kgs/29.7Lbs ■ Color: Black

IR REMOTE CONTROL
CT-IRLED/RM



Use the SGM LED IR REMOTE to control Palco 3, Palco 3 White, Palco 3 Mobile, Genio Mobile and Ribalta LED series fixtures. Just point it at any of these and make selection by pressing buttons to make quick changes.

Specifications: 22 total buttons ■ On/Off control ■ Control and storage of Pan and Tilt (for Mobile units) ■ Control of macros, programs, color combinations (20 presets) ■ Useable for all color changing LED units in the SGM line. ■ Screen Display ■ Adjustment of RGB color mixing ■ Power: 2 x AAA Batteries ■ Weight: 0.1Kgs/0.23Lbs ■ Size: 1"x2.5"x0.675" ■ Color: Black



DL-PALCOLENS-8

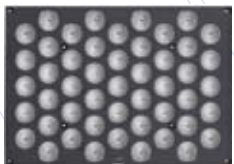

DL-PALCOLENS-40



DL-PALCOLENS-10X22V

PALCO 3 & 5 Lenses:

CODE	DESCRIPTION
DL-PALCOLENS-25	Palco 3 & 5 Lens 25°
DL-PALCOLENS-40	Palco 3 & 5 Lens 40°
DL-PALCOLENS-8	Palco 3 & 5 Lens 8°
DL-PALCOLENS-10X22H	Palco 3 & 5 Lens 10° x 22° Horizontal Lens - no plug
DL-PALCOLENS-10X22V	Palco 3 & 5 Lens 10° x 22° Vertical Lens - no plug

RIBALTA

DL-RIBALTA3-X (X = Lens beam angle)



Cheyenne Saloon,
Orlando FL



RIBALTA is an advanced color changing projector with 90 Luxeon LEDs, which enables the user to illuminate evenly with diffused light beams on large areas such as walls, theaters, TV studio backdrops, cyc curtains and architectural concepts. With the variety of lens choices, it is possible to locate the unit in many narrow areas and have a long throw alongside a near surface. The additional interchangeable lenses are asymmetric 8°, asymmetric 30° and, elliptical 10°x90°. The RIBALTA has top color efficiency. For example, the red's intensity is the same as

that of a 750w halogen lamp source, but consumes less than 100w, an advantage of both low power consumption and high color rendering. Ribalta's IP65 rating makes it suitable for both indoor and outdoor use. It is quick and easy to install using two fastlock clamps or may be permanently mounted using hardware.

Specifications: LED color mixing RGB additive ■ 30 Luxeon Blue 1W LEDs ■ 30 Luxeon Green 3W LEDs ■ 30 Luxeon Red 1W LEDs ■ Luminosity 3,500 Lumens ■ Power Consumption 180w ■ Color temperature: 5,500°K (variable) ■ Interchangeable lenses: 8°, 30° Asymmetric, Elliptical 10 x 90° ■ LEDs average life: 100,000 hours ■ Power: auto ranging 90-270vAC-50/60Hz ■ 8 DMX Channels: 1-Strobe/Shutter, 2-Dimmer, 3-Red, 4-Green, 5-Blue, 6-CTC, 7-Macros, 8-Color Mode ■ Interface LED display with 3 buttons ■ Internal Microcomputer Function Menu (software updatable via DMX) ■ Pan +/- 45° ■ Tilt +15°, -70° ■ Insulation rating: IP 65 ■ Size: 12.2"x38.2"x9.02" ■ Weight: 16Kgs/35.3Lbs

CODE	DESCRIPTION
DL-RIBALTA3-8	Ribalta LED Fixture - 8° Lens
DL-RIBALTA3-30A	Ribalta LED Fixture - 30° Asymmetrical Lens
DL-RIBALTA3-10x90	Ribalta LED Fixture - 10 x 90° Elliptical Lens

GENIO MOBILE

DL-GENIOM

GENIO MOBILE is a compact, stylish color-changing projector that uses new LED technology to produce unlimited colors. 16 high-power Luxeon LEDs enable it to generate a diffused even light beam. Furthermore, the beam of light may be aimed and moved by the motorized pan & tilt functions. Its movements are virtually silent.

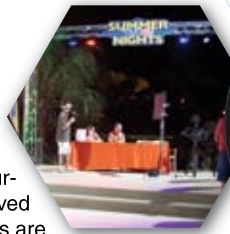

Wet 'n Wild,
Orlando FL



The GENIO MOBILE is totally silent; the fixture is convection cooled by means of its rear finning, and an electronic self regulating internal temperature system to ensure continuous operation.

GENIO MOBILE was designed and built for the countless situations in which design, agility and compact dimensions are required. Applications range from sales outlets, art galleries, television studios, theaters and night clubs. GENIO MOBILE is suitable for indoor and outdoor operation, as it's protected to an IP65 rating.

Specifications: LED color mixing RGB additive ■ 4 Luxeon Blue 3W LEDs ■ 8 Luxeon Green 3W LEDs ■ 4 Luxeon Red 3W LEDs ■ Luminosity 1,500 Lumens ■ Power Consumption 180w ■ Color temperature: 6,000°K (variable) ■ Optional Interchangeable lenses: 8°, 25°, 40° ■ LEDs average life: 100,000 hours ■ Power: auto ranging 90-270vAC-50/60Hz ■ 13 DMX Channels: 1-Strobe/Shutter, 2-Dimmer, 3-Red, 4-Green, 5-Blue, 6-CTC, 7-Macros, 8-Color Mode, 9-Pan H, 10-Pan L, 11-Tilt H, 12-Tilt L, 13-Motor Speed ■ Interface LED display 3 buttons ■ Internal Microcomputer Function Menu (software updatable via DMX) ■ Pan 540° ■ Tilt 270° ■ Insulation rating: IP 65 ■ Size: 9.5"x10.2"x11.8" ■ Weight: 6.5Kgs/35.3Lbs

8°, 25°, 40° lenses fit Genio and Genio Mobile series fixtures.
Specifications: Size: 6.87"x4.87"x0.75" ■ Weight: 0.23Kgs/0.51Lbs Color: Black

DL-GENIOLENS-8

Genio 8 degree lens produces a narrow beam of light that is useful in long throw applications or when a narrow shaft of light is necessary. 8 Degree beam spread.



DL-GENIOLENS-25

Genio 25 degree lens produces a medium beam of light that is useful to create a wash light / flood effect. 25 Degree beam spread.



DL-GENIOLENS-40

Genio 40 degree lens produces a wide beam of light that is useful to create a wash light / wide flood effect. 40 Degree beam spread.



GENIO

DL-GENIORGB

GENIO is an extremely reliable high-tech color-changing fixture able to ensure even, perfectly controllable wash lighting, generated by 16 high-power Luxeon LEDs. Thanks to its compact low-impact dimensions, GENIO is excellent for dynamic interior lighting for commercial applications such as shops, hotels, bars and restaurants, as well as art galleries and meeting rooms. The additional protection of IP65 enables it to be used for outdoor architectural illumination, such as tent events, urban sites, monuments, fountains and cruise liners. Requires the purchase of an optional 8, 25 or 40 degree lens. Upon request: unit is available for White light applications using 12 WHITE LEDs and 4 AMBER LEDs instead of an RGB LED color mixing system. GENIO can be remote controlled via an optional dedicated IR control unit.

DL-GENIORGB - RGB Color Mixing Unit

Specifications: 3 watt LED ■ 4 Luxeon Blue LEDs ■ 8 Luxeon Green LEDs ■ 4 Luxeon Red LEDs ■ Luminous flux 1,500 Lumens ■ Luminous power 100w ■ Power Consumption 60w ■ Color temperature: 6,000°K (variable) ■ RGB color mixing ■ Optional Interchangeable Beam: 8° lens, 25° lens and 40° lenses ■ LEDs life: average 100,000 hours at maximum power ■ Manual Pan +/- 135° ■ Manual Tilt +/- 135° ■ Control: 8 DMX Channels RDM protocol (for internal functions setting) ■ Settings via RDM ■ Internal Microcomputer ■ software updatable via DMX ■ IP 65 Insulation Degree ■ Mounting plate included for wall or clamp attachment ■ Power: 90-270vAC 50/60Hz ■ Size: 9.45" x 9.45" x 4.65" ■ Weight: 4Kgs/8.82Lbs

DL-GENIOW - White LED Unit

Specifications: 4 Luxeon Amber LEDs - 3W ■ 12 Luxeon White LEDs - 3W ■ Luminous flux 1,800 Lumens ■ Color temperature: 2,000 – 6,700°K (variable)

DL-GENIOW4K - All White LED Unit

Specifications: 16 Luxeon White LEDs - 3W ■ Luminous flux 1,800 Lumens ■ Color temperature: 4200°K

Specifications are subject to change without notice.

IDEA LED 100

DL-IDEALED100



Original design, compact lines and extraordinary light weight are the features that immediately impress. Idea Moving Led 100 creates a soft perfectly controllable light beam, using its 60 LED matrix.

The RGB+W color mixing system creates endless exciting colors, from the brightest tones to the softest hues.

Practical operation and simple maintenance make Idea Moving Led 100 the perfect solution for show business.

Specifications: 60 3W high power RGBW LEDs ■ LEDs life: 100,000 hours ■ Excellent color mixing and rainbow effect ■ Automatic operation master and slave ■ Beam angle: 28° ■ Optional lenses offer various projection angles ■ Sync with music ■ 8 pre-built programs ■ General dimming and blackout ■ Strobe 1-25 flash/second and pulse effect ■ Pan 540° (optional 630°) ■ Tilt 265° ■ 16 bit resolution ■ DMX 512 input signal ■ 13 DMX channel ■ DMX Data In/Out: 3 and 5 Pin XLR ■ Wireless DMX interface as standard ■ RDMX: remote DMX addressing ■ Sound control switch by controller ■ LCD display ■ Mounting: unit includes 2 Omega Mounts ■ Power: 100-240vAC 50/60Hz ■ Rechargeable Back up Battery ■ Settings viewable on display, even with fixture off ■ Size: 11.8"x8.7"x15.28" ■ Weight: 6Kgs/13.5Lbs

IDEA LED 300

DL-IDEALED300

Energy efficiency, carefully studied design, silent operation and power are the distinctive elements of Idea Moving Led 300. A matrix of 108 high-power LEDs produces a wash with exceptional colors, whose shades vary from the deepest tones to the softest lightest ones.

Optional interchangeable lenses offer various projection angles and allow Idea Moving Led 300 to be used at different distances from the objects to be illuminated. Their extremely easy intuitive operation make Idea Moving Led 300 the ideal solution for touring, television studios and night venues.

Specifications: 108 3W high power RGBW LEDs ■ LEDs life: 100,000 hours ■ Excellent color mixing and rainbow effect ■ Automatic operation master and slave ■ Beam angle: 39.5° ■ Optional lenses offer various projection angles ■ Sync with music ■ 8 pre-built programs DIMMER – STROBE ■ General dimming and blackout for all four colors ■ Strobe 1-25 flash/second and pulse effect ■ Pan 540° (optional 630°) ■ Tilt 265° ■ 16 bit resolution ■ DMX 512 input signal ■ 13 DMX channel ■ DMX Data In/Out: 3 and 5 Pin XLR ■ Wireless DMX interface as standard ■ RDMX: remote DMX addressing ■ Sound control switch by controller ■ LCD display ■ Mounting: unit includes 2 Omega Mounts ■ Power: 100-240vAC 50/60Hz ■ Rechargeable Back up Battery ■ Settings viewable on display, even with fixture off ■ Size: 11.8"x9"x17.2" ■ Weight: 9Kgs/19.8Lbs



IDEA BEAM 300

IL-IDEA300BEAM

Idea Beam 300 uses a 300W lamp for a very narrow highly concentrated light beam. The beam can be colored and shaped by applying the vast range of effects provided: CMY color mixing system, color wheel with 8 colors + white, 8 rotary indexable and customizable gobos, rotary three-facet prism.

Light weight and compact dimensions, wireless DMX interface fitted as standard and energy efficiency make Idea Beam 300 the perfect instrument for touring, television studios and night venues.

Specifications: LAMP: PHILIPS MSR 300 FASTFIT ■ Remote lamp on/off via DMX ■ CMY color mixing and speed adjustable ■ Color wheel: 8 interchangeable dichroic filters plus open ■ 30 CMY and color wheel MACROS and Random CMY ■ 6 rotating, interchangeable, indexable gobo plus open ■ Slot in & out gobo/color wheel system ■ 1 rotating and indexable prism (3 facets) ■ Frost from 0 to 100 ■ Sync with music ■ Shutter ■ Strobe 1-13 flashes/second random strobe ■ Linear dimmer intensity from 0 to 100 ■ Pan 540° (optional 630°) Tilt 265° ■ 16 bit resolution ■ DMX 512 input signal ■ 16, 18, or 26 DMX channels ■ DMX Data In/Out: 3 and 5 Pin XLR ■ Wireless DMX interface as standard ■ RDMX: remote DMX addressing, Sound control switch by controller ■ LCD display ■ Rechargeable Back up Battery ■ Settings viewable on display, even with fixture off ■ Electronic ballast ■ Mounting: unit includes 2 Omega Mounts ■ Power: 100-240vAC 50/60HZ ■ Size: 16.9"x14.17"x20.1" ■ Weight: 25Kgs/55Lbs



IDEA

X-LINE IDEA moving heads were created to provide high quality and performance with an exceptional quality to price ratio. IDEA line moving head models offer great reliability and a stylish modern design - fitted with 575w discharge lamps. Innovative technologies allow for smooth, precise, and speedy movements using precision stepper motors. A wash and spot version of each wattage exist. The numerous eye catching effects that can be created with the IDEA line are only limited by your imagination.



IL-IDEA575SPOT/1

IDEA SPOT 575 is fitted with a 575W discharge lamp whose ignition is controlled from the lighting console, two gobo wheels that can be personalized, a color wheel, adjustable mechanical iris diaphragm with various pulse effect speeds and a 3-facet prism. The unit has electronic focus and 18°, 21°, 24° step zoom. IDEA SPOT 575 has 8 preset programs + 48 programmable scenes and can be used in master or slave mode; pan and tilt reset are automatic.

Specifications: Light Source: MSR575/2 or CSR575/2SE, 7200°K ■ Remote lamp on/off via DMX ■ Color wheel with 8 dichroic colors + white ■ Adjustable speed color wheel rainbow effect ■ Indexable rotating gobo wheel with 6 gobos plus open ■ Different speed gobo shake effect ■ Static gobo wheel with 7 gobos plus open & gobo shake effects ■ Automatic operation master and slave modes ■ Audio sync to the beat of the music ■ 8 built-in programs ■ 48 programmable scenes ■ Color and gobo change with blackout feature ■ 1 rotating indexing prism (3 facets) ■ Number of scenes in Program Run can be changed individually ■ Iris from 5% to 100%, with pulse iris effect ■ Linear Frost ■ Electronic focus ■ Stepped zoom: 18°, 21°, 24° ■ Dimmer intensity from 0 to 100% ■ Shutter & Strobe 0-13 flash/second ■ Movement: Pan 540° (optional 630°) & Tilt 265° ■ 8/16 bit resolution ■ Pan & tilt speed control ■ Automatic Pan Tilt repositioning correction ■ DMX 512 input signal ■ DMX data connections in/out: (both)

3 and 5 Pin XLR on board ■ DMX Channels: 16 DMX channels in 16 bit or 14 DMX channels in 8 bit mode ■ Auto test all functions ■ Display the value of each DMX channel ■ Display "flip" function 180° rotation ■ Mounting: includes 2 omega mounts where standard clamps may be attached ■ Power: 120vAC 50/60 Hz, on request 230v ■ Current draw: 7 amps ■ Size: 19.7"x19.7"x15.4" ■ Weight: 38.5Kgs/84.70Lbs ■ Color: Black



IL-IDEA575WASH/1

IDEA WASH 575 is fitted with a 575W discharge lamp whose ignition is controlled by the lighting console, a color wheel with seven dichroic filters, color temperature correction filters, an effects wheel with beam shaper and frost filter and an advance CMY color mixing system. IDEA WASH 575 has 8 preset programs + 48 programmable scenes and can be used in master or slave mode; it also has automatic pan and tilt reset.

Specifications: Light Source: MSR575/2 or CSR575/2SE, 7200°K ■ Remote lamp on/off via DMX ■ Color wheel with 7 dichroic colors + white ■ Adjustable speed color wheel rainbow effect ■ Advanced CMY color mixing ■ 2 color temperature correction filters ■ Automatic operation master and slave modes ■ Audio sync to the beat of the music ■ 8 built-in programs ■ 48 programmable scenes ■ Color change with blackout feature ■ Effect wheel: beam shaper and frost filter ■ Motorized zoom 7° - 28° ■ Dimmer intensity from 0 to 100% ■ Shutter & Strobe 0-13 flash/second ■ Movement: Pan 540° (optional 630°) & Tilt 265° ■ 8/16 bit resolution ■ Pan & tilt speed control ■ Automatic Pan Tilt repositioning correction ■ DMX 512 input signal ■ DMX data connections in/out: (both) 3 and 5 Pin XLR on board ■ DMX Channels: 16 DMX channels in 16 bit or 14 DMX channels in 8 bit mode ■ Auto test all functions ■ Display the value of each DMX channel ■ Display "flip" function 180° rotation ■ Mounting: includes 2 omega mounts where standard clamps may be attached ■ Power: 120vAC 50/60 Hz, on request 230v ■ Current

draw: 7 amps ■ Size: 19.7"x19.7"x15.4" ■ Weight: 33.5Kgs/73.70Lbs ■ Color: Black

GIOTTO 700

IL-GIOTTO700/S SPOT

Giotto Spot 700 is the latest evolution in the Giotto range of fixtures.

Two types of interchangeable 700 Watt lamps with automatic fast re-strike ensure a luminous output never seen before from a 700W fixture. Giotto Spot 700 features CYM color mixing, to create an unlimited quantity of colors and different shades, linear CTO, two wheels with rotating interchangeable gobos (each with 8 slots plus white) a 6-color plus white color wheel and an easily changeable animation wheel to create all kinds of cool and unique effects.

Giotto Spot 700 completes the Giotto range, offering the maximum to lighting professionals wishing to show their full creativity.

Specifications: Lamp: MSR Gold 700 FastFit (6,000°k or 7,500°k) ■ Fast and automatic lamp re-strike ■ Remote lamp on/off via DMX ■ Lamp power reduction in the event of overheating or when shuttered ■ Lamp hour timer and strike meter ■ Fixture operation time meter ■ 50% lamp power reduction after 7 seconds with shutter or dimmer at 0 ■ Motorized zoom from 9° to 18° ■ Motorized focus ■ CMY color mixing ■ Color wheel: 6 colors + white (interchangeable) ■ Linear CTO filter ■ 2 customizable gobo wheels: 8 rotating indexable gobos (16-bit) ■ Animation wheel (interchangeable) ■ 2-tone color beam ■ Color and Gobo change with audio sync and/or blackout ■ Continuous color wheel rotation ■ UV light effect filter ■ Linear frost ■ Gobo change with music sync and/or blackout ■ 1 rotating prism (4-facet) ■ Linear iris ■ Linear dimmer ■ Shutter ■ Strobe (1-12 flashes per second even with music sync) ■ Pan 540° (2.8 sec.) ■ Tilt 270° (1.7 sec.) ■ 8/16 bit resolution ■ Auto Pan/Tilt repositioning correction ■ Microprocessor controlled setting using digital display panel ■ Display "flip" function (180° rotation) ■ Dimmable display lighting ■ Fixture running time counter ■ Control input: DMX512 or RS 232 input signal ■ Data in/out: 5 pin XLR ■ 33 DMX channels ■ Mounting: includes 2 FASTLOCK pipe clamps ■ Automatic energy saving when the fixture is blacked out ■ Power: electronic ballast universal 90-245vAC 50/60Hz ■ Current draw: 10 amps ■ Size: 29.48"x15.75"x18.35" ■ Weight: 37.6Kgs/82.9Lbs ■ Color: Black



Giotto 700 Wash unit also available: IL-GIOTTO700/W WASH

GIOTTO SYNTHESIS

IL-GIOTTOSYN/S
IL-GIOTTOSYN/W

Specifications are subject to change without notice.



Sasha & Digweed,
House of Blues, Orlando FL



The Giotto Synthesis is the first moving light series to be equipped standard with wireless DMX, allowing you the freedom to program and control your lights from more complicated locations than regular DMX cables will. Another innovative feature is a three-segment modular construction, making your repair issues that much easier by letting you swap out and send in for repair only part of a fixture instead of the fixture itself. And because the Synthesis is so unique, SGM has worked closely with Osram to create two specific lamps with two separate color temperatures (5600°K and 7200°K) to better resolve any color temperature issues you have.

SGM has also responded to the issues of rigorous touring with two new solutions. The first is a unique Pan/Tilt locking and electronic unlocking system, ensuring that your locked fixtures can always be unlocked once connected to a power source (even when already hung on truss). The second is secure protection against power surges of 380V, a common problem in Europe that has fried many lighting fixtures over time.

Of course, some of the best features of the Synthesis are the ones you can see in action! SGM has created a "revolutionary" positionable animation wheel that rotates on a 360 degree axis, allowing for more creative animation options in your lighting designs. The dual Spot/Wash projection feature adds to the Synthesis's versatility, practically giving you two separate fixtures in one.

Along with the Spot/Wash capabilities, the Synthesis has both the infinite palette of CMY color mixing and the precision of 6 interchangeable spot colors. Dual gobo wheels that can each hold eight 16-bit rotating, indexable, interchangeable gobos give you plenty of options for high quality graphic and atmospheric projections, and a 4-facet rotating prism gives you another fun feature to play with. All of the Synthesis's features are an addition to the already extensive features of all Giotto range fixtures, which include the exclusive use of hot re-strike lamps and the silent operation that has made the Giotto's a standard in the industry. And because of all of this, the Synthesis is the perfect moving light for everywhere from theatrical installations to major tours.

Along with the Spot/Wash capabilities, the Synthesis has both the infinite palette of CMY color mixing and the precision of 6 interchangeable spot colors. Dual gobo wheels that can each hold eight 16-bit rotating, indexable, interchangeable gobos give you plenty of options for high quality graphic and atmospheric projections, and a 4-facet rotating prism gives you another fun feature to play with. All of the Synthesis's features are an addition to the already extensive features of all Giotto range fixtures, which include the exclusive use of hot re-strike lamps and the silent operation that has made the Giotto's a standard in the industry. And because of all of this, the Synthesis is the perfect moving light for everywhere from theatrical installations to major tours.

Specifications: HTI 700W SE (7,200°K) or HTI 700W SE (5,600°K) lamp ■ Average lamp life 750 hr. ■ Automatic hot restrike ■ Remote lamp on/off via DMX. ■ Lamp power reduction in the event of overheating ■ Lamp elapsed time and strike counter ■ Advanced CMY colour mixing ■ Customizable color wheel: 4 colours + white ■ Linear CTO filter ■ Frost lens ■ Color change in sync with music and/or with blackout ■ Rainbow color ■ Linear iris diaphragm ■ Motorized zoom (6°- 40°) ■ Linear dimmer ■ Shutter ■ Strobe 1-12 flashes/second, also with music sync. ■ Pan 530° (4 sec.) ■ Tilt 250° (3.4 sec.) ■ Pan / Tilt Lock; electronic Pan / Tilt unlocking ■ Pan/Tilt w. 8/16 bit resolution ■ Automatic Pan/Tilt repositioning ■ DMX 512 or RS 232 input signal ■ 20 DMX channels ■ Ethernet interface (ART-NET protocol) ■ Wireless DMX interface fitted as standard ■ RDM protocol implemented on the DMX (monitoring of internal parameters) ■ Settings via on-board microcomputer viewable on display (even with fixture off) ■ Display "flip" function (rotation through 180°) ■ Adjustable display brightness ■ Fixture elapsed time indicator ■ On-board temperature sensors (base, power, one for each module) ■ Total fixture software update via DMX ■ Graphic display (140 x 16) ■ Power supply with PFC (universal 90-245vAC 50/60Hz); protected against 400V Electronic Ballast ■ Power consumption: Automatic energy saving in the event of blackout use ■ Size: 29.53"x15.75"x18.12" ■ Weight: 39.5Kgs/83.78Lbs

SYNTHESIS

- Wireless DMX
- Modular Construction
- 360° Positionable Animation Wheel
- 700 Watt Single Ended Lamp
- Advanced CMY Color Mixing
- Automatic Hot Restrike
- 5600°k or 7200°k Lamp Temperature

MODULAR CONSTRUCTION

- Sophisticated Features
- Quick & Easy Access
- Rugged Design

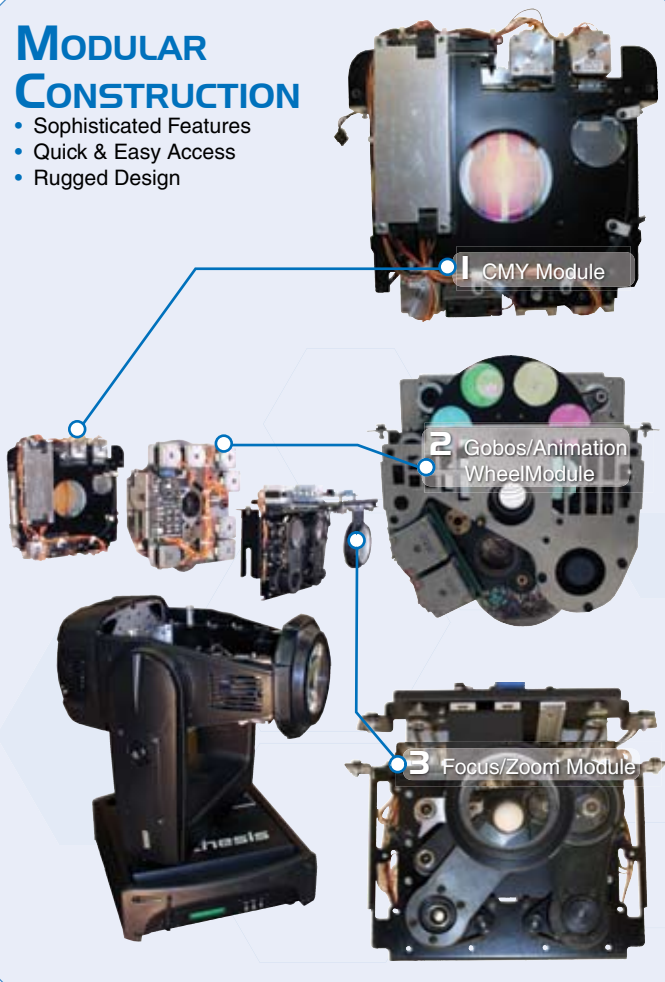

SGM GIOTTO SERIES

GIOTTO 400 SPOT CMY

IL-GIOTTO400SCMY/B

The GIOTTO SPOT 400 CMY is the latest addition to the Giotto 400 Series of moving light fixtures, designed for use in high-profile entertainment applications, in concerts, theatres and television studios. GIOTTO SPOT 400 CMY offers the most advanced features in its class, including a 400w hot re-strikeable MSR lamp source, 9°-24° motorized zoom, advanced CMY color generation mixing system + 1 color wheel with 6 dichroic colors and open, 2 rotating indexable gobo wheels and an animation wheel. In addition the fixture features a linear iris, linear frost, linear CTO filter, 1 rotating prism and an electronic flicker free ballast. GIOTTO SPOT 400 CMY was designed paying great attention to noise levels, silent operation and cooling being a key priority for houses of worship, theatre and television studio applications. The Giotto series is virtually silent. The head movement and the fixture's internal mechanism also have an extremely low noise level. A phonometric test done by Istituto Giordano S.p.a. in an anechoic chamber shows a noise level of only 31.8dB at 1 meter. Its unique cooling system is a hybrid between convection cooling and forced ventilation. Thanks to the thermal interface of the dichroic reflector with a metal heat sink, heat is dispersed towards the rear of the fixture and two very low-speed variable fans ensure sufficient air circulation for perfect fixture operation even when in high surrounding temperatures up to 122 degrees. GIOTTO SPOT 400 CMY is powerful and versatile, yet compact and lightweight; the fixture can be easily transported and installed by a single person, thanks to the rugged and practical handles and 'Fast Lock' hanging clamps. When both the brightness of bigger lamp units and the size of a small projector is needed, the GIOTTO SPOT 400 CMY is the ideal choice!

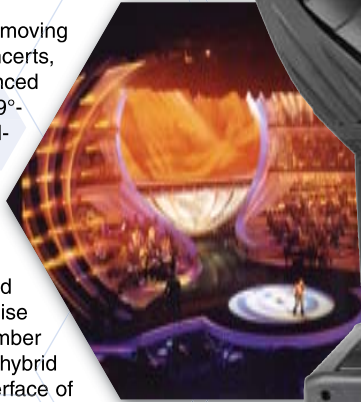

Specifications are subject to change without notice.

Specifications: Lamp: MSR400HR (6,000k) ■ Average lamp life: 750 hours ■ Luminous power: 12,000 Lux at 5 m ■ Automatic lamp re-strike ■ Remote lamp on/off via DMX ■ Lamp power attenuation in the event of overheating or when shuttered ■ Lamp hour timer and strike meter ■ Fixture operation time meter ■ Motorized zoom (9°-24°) ■ Motorized focus ■ CMY color mixing ■ Color wheel: 6 colors + white (interchangeable) ■ Linear color filter ■ 2 Gobo wheels: 8 rotating indexable and interchangeable gobos each ■ Animation wheel (interchangeable) ■ 2-tone color beam splits ■ Color change with music sync and/or blackout ■ Continuous color wheel rotation ■ UV light effect filter ■ Variable frost ■ Gobo change with music sync and/or blackout ■ 1 rotating prism (4-facet) ■ Variable iris ■ Variable dimmer ■ Shutter ■ Strobe (1-12 flashes per second even with music sync) ■ Pan 540° (2.8 sec.) ■ Tilt 270° (1.7 sec.) ■ 8/16 bit resolution ■ Auto Pan/Tilt repositioning and correction ■ Microprocessor controlled setting using digital display panel ■ Display "flip" function (180° rotation) ■ Dimmable display lighting ■ Fast-Lock clamping system ■ Control input: DMX512 ■ 34 DMX channels ■ Automatic energy saving when the fixture is blacked out ■ Power: electronic ballast universal 90-245vAC 50/60Hz ■ Current draw: 7 amps ■ Size: 29.28"x14.38"x16.23" ■ Weight: 33Kgs/72.8Lbs ■ Colors: black or white

GIOTTO 400 PROFILE

IL-GIOTTO400P

GIOTTO 400 WASH

IL-GIOTTO400W/B
(IL-GIOTTO400W/W for white)

GIOTTO 400 SPOT

IL-GIOTTO400S/W
(IL-GIOTTO400S/B for black)



Giotto 400 rotating shutters

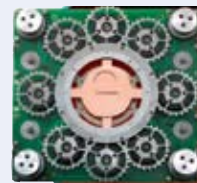

Giotto 400 Profile shaper



LIGHT DOME

AC-LIGHTDOME

This is a cover designed by SGM for outdoor application when using Galileo II 1200, Galileo IV 1200 fixtures and Giotto 400. The dome is highly transparent heat-resistant polycarbonate with a built-in ventilation system and ABS body. Fixtures housed in the dome are protected against weather, vandalism and attempted theft. Domes are available in two standard colors: grey and blue. On request, custom colors are also available for orders of at least 10 units.



Specifications: Power: 220vAC 50/60Hz 30w ■ Size: 39.37"x31.5"x 31.5" ■ Weight: 20Kgs/44.09Lbs

Giotto 400 Fixture Specifications



Specifications are subject to change without notice.

	Spot	Wash	Profile	Spot CMY
Product code	IL-GIOTTO400S	IL-GIOTTO400W	IL-GIOTTO400P	IL-GIOTTO400S/CMY
Silent Operation	■	■	■	■
Lamp	MSR400HR	MSR400HR	MSR400HR	MSR400HR
Luminous power	12,000 Lux at 5m	12,000 Lux at 5m	12,000 Lux at 5m	12,000 Lux at 5m
Color Temperature	6000K	6000K	6000K	6000K
Lamp Life (hours)	750	750	750	750
Automatic hot re-strike	■	■	■	■
Remote lamp on/off via DMX	■	■	■	■
Lamp power reduction in case of overheat	■	■	■	■
Lamp elapsed time and strike meter	■	■	■	■
Fixture operating time meter	■	■	■	■
Motorized linear zoom	9°-24°	19°-38°	16°-24°	9°-18°
Motorized remote focus	■	■	■	■
CMY color mixing	■	■	■	■
3,200° K color conversion filter (full CTO)	■	■	■	■
4,000° K color conversion filter (half CTO)	■	■	■	■
Linear color conversion filter	■	■	■	■
Blacklight (UV) filter	■	■	■	■
Color wheel (customizable)	8 colors +white	7 colors +white	8 colors +white	6 colors +white(interchangeable)
Effect wheel (customizable)	■	■	■	■
Rainbow effect (Color wheel rotation)	■	■	■	■
Color change w/music sync and/or blackout	■	■	■	■
Gobo change w/music sync and/or blackout	■	■	■	■
2-tone beam (color splits)	■	■	■	■
Variable frost	■	■	■	■
Fixed gobos	4	■	■	■
Indexable rotating gobos	48	■	■	■
Gobo size metal: OD/ID	30mm/24mm	■	30mm/24mm	30mm/24mm
Gobo size glass: OD/ID	28mm/24mm	■	28mm/24mm	28mm/24mm
Rotating prism	2	■	■	1 (4-facet)
Animation wheel (interchangeable)	■	■	■	■
Variable iris	■	■	■	■
Strobe: 1-12 fps with music sync	■	■	■	■
Shutter	■	■	■	■
Internal rotating shutters (0°-180°)	■	■	■	■
Internal rotating shaper	■	■	■	■
Linear 0 -100% dimmer	■	■	■	■
Pan 540° and Tilt 270° (speed)	(2.8s) (1.7s)	(2.8s) (1.7s)	(2.8s) (1.7s)	(2.8s) (1.7s)
Automatic Pan/Tilt position correction	■	■	■	■
8/16 bit resolution	■	■	■	■
Power Factor Correction	■	■	■	■
Auto energy saving when blacked out	■	■	■	■
Setting via built-in microcomputer	■	■	■	■
Adjustable display brightness	■	■	■	■
Fast-lock clamping system	■	■	■	■
Display "flip" function (rotation by 180°)	■	■	■	■
Input signal: DMX 512 channels:	22	18	27	34
Electronic ballast	■	■	■	■
Power Consumption:	600w	600w	600w	7amps
Universal voltage input	100-245vAC 50/60Hz	100-245vAC 50/60Hz	100-245vAC 50/60Hz	90-245vAC 50/60Hz
Size:	26.81"x14.37"x16.22"	26.81"x14.37"x16.22"	26.81"x14.37"x16.22"	29.28"x14.38"x16.23"
Weight: Kgs/Lbs	24.8/54.7	24.8/54.7	24.8/54.7	33/72.8
Approvals	ETL / CE	ETL / CE	CE	CE



CS4
IL-CS4

The CS4 is an all around multipurpose multipar that provides you with a solution to any lighting design dilemma you'll come across. Studio Due has designed a simple, elegant, and brilliant lighting fixture that adds a dramatic element to your shows and venues. Made up of four ACL PAR cans that Pan independently of each other. The entire "bar" Tilts as one unit, and can be mounted either horizontally or vertically (or diagonally, if you're really good at rigging). Thanks to the compact design of the CS4, it adds the perfect amount of eye candy to smaller venues that don't have the space or budget for a more elaborate lighting rig. However, the unit fits right in with larger staging events and installations, and adds a completely unique look to the show. If you haven't found the answer to your lighting challenge yet, give the CS4 unit a try!

INFOCOMM,
Orlando FL



Specifications: Lamps: ST 250W 28V or GE4552 250W 28V ■ Lamp life: ST 250W - 300 hours/GE4552 - 50 hours ■ Movement: stepper motor 8 or 16 bit resolution ■ Pan/Tilt: single tilt 200/multiple pan 270 ■ Control: RS-485 DMX 512 ■ 20 DMX channels ■ Built-in microprocessor with display ■ Power: 100vAC/120vAC/230vAC 50/60Hz ■ Power draw: 1100W ■ Current draw: 4.8 amps (230V) ■ Electronic progressive dimmer ■ Size: 78.79"x11.82"x17.72" ■ Weight: 31Kg/68.35Lbs



XS1200
IL-XS1200

The XS1200 encompasses every modern feature in one moving light. Its powerful output makes it perfect for long throw applications like TV studios, sports arenas, theatres and concerts. The optical system of condenser lenses and dichroic mirror reflector is the heart of the projector's luminous output. Remote focus and zoom have been added as well, resulting in the ability to create a vast amount of spectacular effects.



Specifications: Lamp: HTI1200W/D7/60 or MSI1200DE ■ Lamp life: average 750 hours ■ Color temperature: 6000 degree Kelvin ■ Luminous flux: 110,000 lumens ■ Remote Lamp: control on/off by DMX ■ Movement resolution: 16 bit ■ Pan: 460 degrees ■ Tilt: 270 degrees ■ Pan/Tilt auto encoder positioning and correction ■ Color Wheel 1: 5 dichroic colors + 6 bi-colors and color scrolling ■ Color Wheel 2: 3 dichroic colors + 3 bi-colors ■ Conversion Filters: CTO and CTB ■ Gobo Wheel 1: 5 gobos plus open, rotating and indexable ■ Gobo Wheel 2: 5 gobos plus open, rotating and indexable ■ Static Gobos: 3 glass gobos ■ Dimming: Electronically from 100 to 60%, mechanically from 60% to 0. ■ Shutter & Strobe: 1-15 flashes per second ■ Zoom: motorized 17 to 27 degrees ■ Focus: motorized, from 1 meter to infinity ■ Prisms: 2 rotating ■ Iris: motorized from open to close ■ Frost: 2 softening filters + 1 continuous frost ■ Display: microprocessor controlled menus ■ Graphic LCD display with flip function ■

Control Input Signal: DMX512 - opto-isolated in/out ■ DMX Channels: 20 channel control - ch1 = iris, ch2 = color, ch3 = gobo wheel 1, ch4 = strobe/shutter, ch5 = pan coarse, ch6 = pan fine, ch7 = tilt coarse, ch8 = tilt fine, ch9 = dimmer, ch10 = motor speed, ch11 = focus, ch12 = filters, ch13 = gobo wheel 2, ch14 = gobo wheel 2 position index/rotation, ch15 = gobo wheel 1 position index/rotation, ch16 = zoom, ch17 = glasses, ch18 = frost, ch19 = prisms, ch20 = reset / lamp off / pan & tilt ramp ■ Power: 95-260vAC 47/63Hz with power factor correction, electronic power supply ■ Size: 17.13"x17.13"x25.2" ■ Weight: 32Kgs/70.55Lbs ■ Color: Black



COBRA LED

DL-COBRALED/WS

The CobraLED is the first in a series of compact yet stylish LED SPOT moving lights. It is the smallest single arm automated moving-head with 11 brilliant dichroic colors, 7 rotating gobos, dimming and an electronic strobing effect. Its long life light source features a newly developed 40w white LED at its heart. Lightweight design and quick pan & tilt action make this the perfect fixture for mobile DJs, nightclubs, and store displays.

Specifications: Lamp: 40w White LED ■ LED Color Temperature: Cool White ■ Multi-lens coated system ■ Beam angle: 21 degrees ■ Manual focus ■ Gobo wheel: 7 rotating gobos + open ■ Bidirectional and variable speed gobo rotation ■ Color wheel: 11 dichroic colors + open and split colors ■ Variable bidirectional continuous color wheel spin ■ Electronic dimming from 0-100% ■ Electronic quick shutter & strobe effect function ■ Pan and Tilt with feedback auto position correction ■ Pan/Tilt Resolution 16-bit ■ Pan/Tilt invert ■ Hall effect sensors for all effect resets ■ Stepper motors for all mechanical effects ■ DMX512 control input using 3-Pin XLR ■ Control using 9 DMX channels ■ Stand-alone operation ■ Mounting clamp adapter ■ Safety cable attachment point ■ Electronic Transformer ■ 4-digit LED display for user settings ■ Power input: auto-ranging 100-240vAC 50/60Hz ■ Current draw: 2 amps ■ Size: 12"x12"x19.5" ■ Weight: 9.1Kgs/20Lbs



Specifications are subject to change without notice.

TECHNI-LUX FIXTURE RANGE



Moving Heads

TRACKER

250 WASH IL-TRACKER250W/1

Specifications:

Lamp: CSD250/2 or MSD250/2 ■ Lamp life: 3000 hours ■ Color temperature: 8500°K ■ Luminous output: 18,000 Lux ■ Remote lamp on and off ■ Movement resolution: 16 bit ■ Pan: 530 ■ Tilt: 280 ■ Pan/Tilt motor speed ■ Consistent & auto correcting Pan/Tilt ■ Remote reset ■ Color wheel with 6 dichroic colors + open ■ CMY color mixing ■ CMY variable motor speed ■ 30 CMY macros ■ Beam shaper ■ Frost effect ■ Manual zoom: 8 to 22 ■ Variable shutter for strobe & quick blackouts ■ Motorized dimmer from 0 to 100% ■ DMX512 control ■ 3-pin In/Out XLR connection ■ 16 DMX channels ■ Digital display for addressing & fixture settings ■ 140mm fresnel lens ■ Ventilation via forced air ■ Anti-reflective coated glass optics ■ High efficiency parabolic glass reflector ■ Power: 120vAC 50/60Hz ■ Current draw: 4 amps ■ Size: 21"x17"x17" ■ Weight: 26.4Kgs/58Lbs ■ Color: Black



575 WASH IL-TRACKER575W/1

Specifications:

Lamp: CSR575/2SE or MSR575/2 ■ Lamp life: 1000 hours ■ Color temperature: 7200°K ■ Luminous output: 49,000 Lux ■ Remote lamp on and off ■ Movement resolution: 16 bit ■ Pan: 530 ■ Tilt: 280 ■ Pan/Tilt motor speed ■ Consistent & auto correcting Pan/Tilt ■ Color wheel with 7 dichroic colors + open ■ CMY color mixing ■ CMY variable motor speed ■ 18 CMY macros ■ Remote reset ■ Motorized beam shape rotation ■ Frost effect ■ Motorized zoom from 7 to 28 ■ Variable shutter for strobe & quick blackouts ■ Motorized dimmer from 0 to 100% ■ DMX512 control ■ 3-pin In/Out XLR connection ■ 16 DMX channels ■ Digital display for addressing & fixture settings ■ 200mm fresnel lens ■ Ventilation via forced air ■ Anti-reflective coated glass optics ■ Dual heat glass filters n High efficiency glass reflector ■ Power: 120vAC 50/60Hz ■ Current draw: 6 amps ■ Size: 27"x18"x18" ■ Weight: 40Kgs/88Lbs ■ Color: Black



250 SPOT IL-TRACKER250S/1

Specifications:

Lamp: CSD250/2 or MSD250/2 ■ Lamp life: 3000 hours ■ Color temperature: 8500°K ■ Luminous output: 18,000 Lux ■ Remote lamp on and off ■ Movement resolution: 16 bit n Pan: 530 ■ Tilt: 280 ■ Pan/Tilt motor speed ■ Consistent & auto correcting Pan/Tilt ■ Remote reset ■ Color wheel with 7 colors + open and continuous rotation ■ Static effect/gobo wheel with 3 gobos & 3 additional dichroic colors + open ■ 3-facet rotating prism with variable speed in both directions ■ Gobo wheel with 5 rotating, indexable & interchangeable gobos + open and continuous rotation ■ Remote selection of zoom degrees: 15, 18, 21, 24, & 26 ■ Frost effect ■ UV blacklight effect ■ Motorized focus ■ Variable shutter for strobe & quick blackouts ■ Motorized dimmer from 0 to 100% ■ DMX512 control ■ 3-pin In/Out XLR connection ■ 16 DMX channels ■ Digital display for addressing & fixture settings ■ Ventilation via forced air ■ Anti-reflective coated glass optics ■ High efficiency parabolic glass reflector ■ Power: 120vAC 50/60 Hz ■ Current draw: 4 amps ■ Size: 21"x17"x17" ■ Weight: 27.7Kgs/61Lbs ■ Color: Black



575 SPOT IL-TRACKER575S/1

Specifications:

Lamp: CSR575/2SE or MSR575/2 ■ Lamp life: 1000 hours ■ Color temperature: 7200°K ■ Luminous output: 49,000 Lux ■ Remote lamp on and off ■ Movement resolution: 16 bit ■ Pan: 530 ■ Tilt: 280 ■ Pan/Tilt motor speed ■ Consistent & auto correcting Pan/Tilt ■ Remote reset ■ Color wheel with 9 dichroic colors + open and continuous rotation ■ Additional color wheel with 9 dichroic colors + open ■ UV blacklight effect ■ 3-facet rotating prism with variable speed in both directions ■ Static effect/gobo wheel with 9 gobos + open ■ Gobo wheel with 6 rotating, indexable, interchangeable gobos + open and continuous rotation ■ Remote selection of zoom degrees: 15, 18, & 22 ■ Motorized focus ■ Motorized iris ■ Variable shutter for strobe & quick blackouts ■ Motorized dimmer from 0 to 100% ■ DMX512 control ■ 3-pin In/Out XLR connection ■ 17 DMX channels ■ Digital display for addressing & fixture settings ■ Ventilation via forced air ■ Anti-reflective coated glass optics ■ High efficient parabolic glass reflector ■ Power: 120vAC 50/60Hz ■ Current draw: 6 amps ■ Size: 27"x18"x18" ■ Weight: 41.2Kgs/91Lbs ■ Color: Black

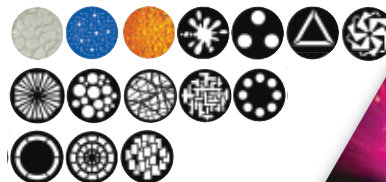

Aqua Lounge,
Daytona FL



TABU,
Orlando FL

CITY COLOR 400

AR-CITYCOL400/2

Specifications:

- Lamps: 2 per unit, type CDM-T150W lamps, 3000k or 4200k
- Colors: Full CYM color mixing, unlimited variety of colors and shades Shutter & dimming function
- Beam angle (50%): 45 degrees
- Rating: IP 66
- Control Input: DMX512
- DMX channels: ch1-motor speed, 2-cyan, 3-yellow, 4-magenta, 5-dimmer, 6-macro colors/rainbow, 7-remote reset
- Configuration: setup using menu driven control panel
- Automode: Stand-alone & auto mode function for master/slave with 27 programs
- Power: 208-230vAC 50/60Hz with power factor correction
- Current draw: 2.4 amps
- Size: 18.9"x19.29"x29.13"
- Weight: 31Kgs/68.34Lbs



CITY COLOR 300

AR-CITYCOL300/2

Specifications:

- Lamps: 2 per unit, type CDM-T150W lamps, 3000k or 4200k
- Colors: Full CYM color mixing, unlimited variety of colors and shades
- Beam angle (50%): 45 degrees
- Rating: IP 66
- DMX channels: ch1-motor speed, 2-cyan, 3-yellow, 4-magenta, 5-unused, 6-macro colors/rainbow, 7-remote reset
- Configuration: setup using internal dip switches
- Automode: Stand-alone & auto mode function for master/slave with 27 programs
- Power: 208-230vAC 50/60Hz with power factor correction
- Current draw: 2.4 amps
- Size: 18.9"x19.29"x29.13"
- Weight: 31Kgs/68.34Lbs



Lamp Selection:

	CDM-T150W/830	CDM-T150W/942
Color Temperature:	3000°k	4200°k
Average Life:	6000 hours	6000 hours
Luminous flux:	14,000 lumens	12,700 lumens
Burning position:	Universal	Universal

MINI CITY 100, 150, 250

MiniCity is a series of medium power outdoor/indoor architectural fixtures. They come in a variety of wattages: 70, 150 and 250. By using an efficient optical and patented CYM color mixing system, these fixtures can create a smooth and unlimited assortment of colors and project with a wide coverage area. Cross-fading from one color to the other is seamless and can be gradual. All fixtures are IP66 rated for outdoor use.

AR-MINICITY100/1



- Lamp: Discharge CDM-T70W/830 or CDM-T 70W/942 (PHILIPS)
- Color temperature: 3,000°k (CDM-T 70W/830) or 4,200°k (CDM-T 70W/942)
- Average lamp life: 12,000 hours
- Luminous flux: 6,600 lumens
- Burning position: Universal
- Full CYM color mixing, unlimited variety of colors and shades
- High resolution stepper motors
- Beam angle (50%): 20 degrees
- Rating: IP 66
- Control input: DMX 512
- 7 DMX channels: 1-motor speed, 2-cyan, 3-yellow, 4-magenta, 5-unused, 6-macro colors/rainbow, 7-remote reset
- Automode: Stand-alone control or auto mode master/slave with 27 programs
- Power: 117vAC or 230vAC 50/60Hz (internal voltage selector)
- Current draw: 1.11 amps at 117v
- Size: 12.6"x12.4"x18.9"
- Weight: 10Kgs/22.05Lbs

AR-MINICITY150S/2



- Lamp: Mastercolor CDM-T 150W/942 or CDM-T150W/830
- Average lamp life: 6000 hours
- Color temperature: 3,000°k (CDM-T 150W/830) or 4,200°k (CDM-T 150W/942)
- Luminous flux: 14,000 lumens
- Beam angle: (50%): 15 degree (on request parabolic for 28 deg wide beam)
- Full CYM color mixing, unlimited variety of colors and shades
- High resolution stepper motors
- Color crossfades can be programmed at four different speeds or in real time
- Rating: IP 66
- Shutter + Dimmer
- Control input: DMX 512
- 6 DMX channels: 1-motor speed, 2-cyan, 3-yellow, 4-magenta, 5-dimmer, 6-macro color
- Automode: Stand-alone control or auto mode master/slave with 27 programs
- Power: 230vAC 50/60Hz
- Current draw: 2.5 amps
- Size: 16.15"x8.27"x20.28"
- Weight: 13Kgs/28.67Lbs

AR-MINICITY250/1



- Lamp: discharge MSD250/2
- Average lamp life: 2000 hours
- Color temperature: 8500°k
- Luminous flux: 18,000 lumens
- Rating: IP 66
- Beam angle: motorized -11 to 14 degrees with standard reflector -20 to 25 degrees with optional 28 degree wide parabolic reflector
- Full CYM color mixing unlimited variety of colors and shades
- High resolution stepper motors
- Shutter + Dimmer
- Configuration of settings via display control panel
- Control input: DMX 512
- 7 DMX channels: 1-motor speed, 2-cyan, 3-yellow, 4-magenta, 5-dimmer, 6-beam angle, 7-remote reset / lamp
- Automode: Stand-alone control or auto mode master/slave with 27 programs
- Power: 120vAC 50/60Hz
- Current draw: 3 amps
- Size: 17.32"x8.66"x22.83"
- Weight: 18Kgs/39.68Lbs

Specifications are subject to change without notice.

CITY COLOR 1800 & 2500

AR-CITYCOL1800
AR-CITYCOL2500

City Color is a high power outdoor/indoor wash fixture. It is available in two versions, an 1800 and a 2500 watt. Both units are IP54 rated for outdoor exposure and feature efficient optical systems. The City Color uses an internationally patented CYM color mixing system which produces even color when lighting very spread out surfaces. An endless number of colors can be created and fading from one color to another is seamless. Its on board control panel and display allow the user to set the fixture's many functions and check running hours of the unit and lamp life. The cooling system is controlled by a microprocessor and together with the thermal switch guarantee a perfect operating temperature with very little maintenance required; often the only service needed is lamp replacement. The unit can run in stand alone mode with built in scene programs and can master/slave with other units. DMX can be used to individually control each function and synchronize multiple units.

General Specifications:

- IP rating: 54
- Beam angle: 50 x 52 degrees
- Color mixing: full CYM using high resolution stepper motors
- Dimmer: 0-100% mechanical
- 7 DMX Channels: ch1-motor speed, 2-cyan, 3-yellow, 4-magenta, 5-dimmer, 6-color macros, 7-remote reset / lamp off
- Automode: stand-alone master/slave function with 27 built-in programs
- Power: 208-220-230-240vAC 50/60Hz, with power factor correction
- Size: 30.7"x22.05"x29.13"

	AR-CITYCOL1800	AR-CITYCOL2500
Lamp:	LMHN1800-P	HMD2500 - MHN-SA2500w
Lamp life:	average 2500 hours	average 2000 hours
Color temperature:	5600 degrees Kelvin	6000 degrees Kelvin
Luminous flux:	180,000 lumens	260,000 lumens
Current draw:	10 Amps	14 Amps
Weight:	55Kgs/121.26Lbs	67Kgs/147.7Lbs

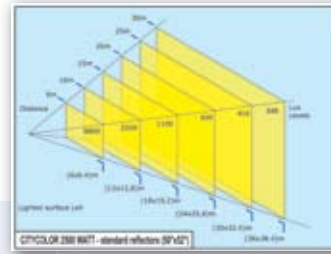

AR-CITYCOL2500

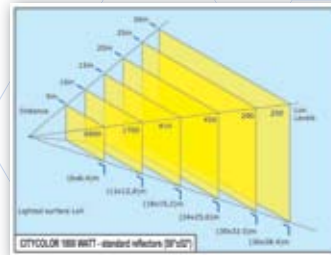

AR-CITYCOL1800



AR-CITYCOLBARN
City Color Barn Doors

Four leaf barn doors are available to help control and define the illumination area on the City Color units. This barn door attaches directly on to the front of the fixture.



AR-CITYBEAM1800

CITY BEAM 1800

AR-CITYBEA1800

City Beam 1800 is an IP rated outdoor fixture for illuminating large areas from a long throw distance. Its efficient optical system is controlled by stepper motors and can produce a variable beam angle from 5 to 8 degrees and 11 to 14 degrees with the diffuser.

The IP54 rated version unit offers an intuitive display menu control panel and a microprocessor controlled cooling system. The control circuits and the thermal switch guarantee a perfect operating temperature making maintenance an infrequent event. Usually the only service required is lamp replacement. Fixture and lamp hours are also displayed on the control panel.

Specifications:

- IP rating: 54
- Lamp: LMSR2000SA-P
- Lamp life: average 750 hours
- Color temperature: 5600 degrees kelvin
- Luminous flux: 150,000 lumens
- Remote beam angle control: 5 to 8 degrees, with diffuser: 11 to 14 degrees
- Color mixing: full CYM using high resolution stepper motors
- Dimmer: 0-100% mechanical
- Shutter
- 7 DMX Channels: ch1-motor speed, 2-cyan, 3-yellow, 4-magenta, 5-dimmer, 6-beam angle, 7-remote reset /lamp off
- Automode: stand-alone master/slave function with 27 built-in programs
- Power: 208-230vAC 50/60Hz, with power factor correction
- Current draw: 11 Amps
- Size: 30.7"x22.05"x29.13"
- Weight: 51Kgs/112.4Lbs

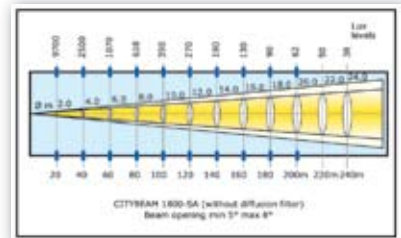
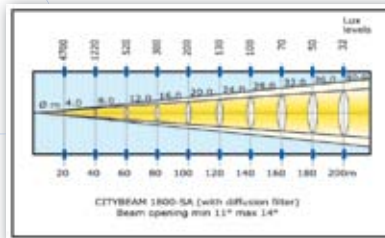



MojoScan II IL-MOJOSCAN2

The Mojo Scan 2 is our most compact X/Y mirror scanning fixture. It features a great selection of 13 gobo patterns and 15 colors at an affordable price point. The high output is attributed to the long lasting 150w metal halide lamp. Mojo Scan 2 can operate in stand alone audio mode as master/slave or via DMX using 4 channels of control. Its gobo and color wheels are separate, allowing the possibility of many combination effects. All mechanical functions use high quality stepper motors. Focusable using manual turn Lens.

Specifications: HTI 152w (included) or HTI 150w Lamp ■ Color wheel: 9 dichroic colors plus 6 color splits ■ Gobo wheel: 13 patterns ■ 1-4 fps shutter strobe effect using gobo wheel ■ Standalone Audio Master/Slave operation ■ DMX control via 4 channels ■ 3-Pin XLR input for DMX ■ Power: 120vAC 50/60Hz ■ Current Draw: 2.5 Amps ■ Size: 18.7"x8.7"x6.3" ■ Weight: 8.6Kgs/19Lbs ■ Color: Black



SHIVA SCANS

The Shiva is an excellent X/Y programmable mirror scanner that projects a brilliant beam of light through its large optical path. All its functions are controlled via DMX512. Separate color and gobo wheels. These fixtures are stylish and value engineered for reliable performance.

HALOGEN 250w VERSIONS

SHIVA IL-SHIVA

Specifications: X/Y Mirror: pan 170° & tilt 90° ■ Die-cast aluminum case ■ 9 colors plus white ■ 9 interchangeable gobos ■ Manual adjustable focus lens ■ Coated lenses: AR & IR ■ Beam Spread: 14.25 degrees ■ Strobe effect, 1-5 fps ■ 4 stepper motors ■ DMX input via 3-Pin XLR ■ DMX control on 4 channels ■ Dip Switch for address & function settings ■ Fan cooling ■ Mounting bracket ■ 37 foot candles at 33 feet ■ Lamp: EVC 250w 24v ■ Power: 120vAC 50/60hz, 3.5 amp current draw ■ Size: 26.3"x11.8"x7.1" ■ Weight: 15Kgs/33.1Lbs

SHIVA R w/ rotating Gobos IL-SHIVAR

Specifications: X/Y Mirror: pan 170° & tilt 90° ■ Die-cast aluminum case ■ 9 colors plus white ■ 6 interchangeable and variable speed, bi-directional rotating gobos ■ Manual adjustable focus lens ■ Coated lenses: AR & IR ■ Beam Spread: 14.25° ■ Mechanical dimming and strobe effect from 1-7 fps ■ 6 stepper motors ■ DMX input via 3-Pin XLR ■ DMX control on 6 channels ■ Dip Switch for address & function settings ■ Fan cooling ■ Mounting bracket ■ 37 foot candles at 33 feet ■ Lamp: EVC 250w 24v ■ Power: 120vAC 50/60Hz, 4.5 amp current draw ■ Size: 26.3"x11.8"x7.1" ■ Weight: 15Kgs/33.1Lbs

METAL HALIDE 200w VERSION

SHIVA R 200 w/ rotating Gobos IL-SHIVA200R

Specifications: X/Y Mirror: pan 170° & tilt 90° ■ Die-cast aluminum case ■ 9 colors plus white ■ 6 interchangeable and variable speed, bi-directional rotating gobos ■ Manual adjustable focus lens ■ Coated lenses: AR & IR ■ Beam Spread: 14.25° ■ Mechanical dimming and strobe effect from 1-7 fps ■ 6 stepper motors ■ DMX input via 3-Pin XLR ■ DMX control on 6 channels ■ Dip Switch for address & function settings ■ Fan cooling ■ Mounting bracket ■ 40 foot candles at 33 feet ■ Lamp: MSD 200 long lasting metal halide ■ Power: 120vAC 50/60hz, 5 amp current draw ■ Size: 26.3"x11.8"x7.1" ■ Weight: 15.9Kgs/35Lbs

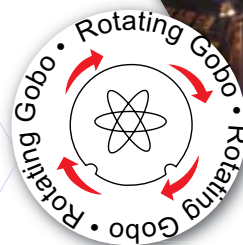

Specifications are subject to change without notice.

Specifications are subject to change without notice.



GALILEO

The Galileo series of intelligent fixtures are high-power scanners with professional performance. Some of the distinguishing features are: high-speed colour and gobo changes, low-noise iris, high-speed gobo and prism rotation, precision linear dimmer, high strobe rate, 16-bit scanning resolution and the possibility of running color changer, gobo changer and strobe in sync with the music. The electronic system is modular and each function has its own independent control card, this facilitates maintenance and cuts running costs. Galileo scanners can be used for a wide variety of applications: from installation in professional sectors such as theatres and television studios to more widespread applications such as bands, entertainment venues, clubs and permanent installations.



IRIS



Specifications for both fixtures: Lamp: HMI1200/GS ■ Lamp life: 750 hours ■ 2-tone beams ■ Color change with blackout ■ Analog color change ■ Color change with music sync ■ Variable speed rainbow effect ■ 3,200 °K CTO color conversion filter ■ Wash frost filter ■ Blacklight-UV filter ■ Layerable gobos: 25 combinations ■ Gobo change with blackout ■ Gobo change with music sync ■ 3-speed continuous gobo wheel rotation ■ Shutter /Strobe 0.5-12 fps ■ 0-100% linear dimmer ■ Iris ■ Pan/Tilt: 180°(0.4 sec.)/ 90°(0.2 sec.) ■ 8/16 bit resolution ■ DMX 512 & RS 232 input signal ■ Power supply 220/240vAC 50/60Hz (100/120V on request) ■ Thermal cut-off ■ Built-in microcomputer.



GOBO WHEELS



IL-GALILEO4: Colors: 75 ■ 6,500°K CTB color conversion filter ■ Soft edge frost filter ■ 4-color filter ■ Concentric 2-color filter ■ Rotating gobos: 8 ■ 9 -facet fixed prism ■ 4 -facet rotating prism ■ Rotating eccentric prism ■ Electronic focus ■ Channels: 16 (18 in 16 bit mode) ■ Dimensions: 8.3"x45.1"x11.4" ■ Weight: 44 Kgs/97Lbs

IL-GALILEO2: Colors: 16 ■ 4 fixed gobos ■ 4 Rotating gobos ■ 4-facet fixed prism ■ Manual focus ■ Channels: 10 (12 in 16 bit mode) ■ Size: 8.3"x45.1"x11.4" ■ Weight: 39.5Kgs/87Lbs



GALILEO IV GOBO WHEELS



VICTORY II 250

IL-VICTORY250

The Victory II is a fixture offering avant-garde performance, powerful light output and innovative technical features, including 16-bit mirror movement control and automatic freestanding operation without any need for a controller. SGM's lengthy experience in the lighting control field has enabled the development of a product which is highly reliable and precise and whose mechanics, optics and electronics have been entirely designed by SGM. Thanks to the compact lines, Victory II scanners are suitable for an endless variety of applications, from fixed installations to mobile set-ups, and have been designed to function almost any position.

Specifications: Lamp EVC 24V 250W halogen ■ Lamp life: 300 hours ■ 16 Colors ■ Two-tone beams ■ Color change with blackout ■ Analog color change ■ Color change with music sync ■ Rainbow effect with adjustable speed ■ CTB color conversion filter ■ Frost filter ■ 4 Fixed gobos ■ Rotating gobos ■ Gobo change with blackout ■ Analog gobo change ■ Gobo change with music sync ■ Continuous gobo rotation ■ 4-facet rotating prism ■ Shutter ■ Strobe 1-9 flashes per second ■ Manual focus ■ Pan/Tilt: 180°(0.5 s)/90°(0.3 s) ■ 8/16 bit resolution ■ Stand-alone functions ■ 10 Channels (12 in 16 bit) ■ DMX 512 -RS 232 input signals ■ Automatic power cut-off in the event of overheating ■ Power supply: 110v or 220vAC 50/60Hz ■ Dimensions: 7.1"x25.6"x13.8" ■ Weight: 14Kgs/30.9Lbs





Tripod stand sold separately. See page 50.

TRACER 2 1200

FS-TRACER2M

The Tracer2 1200 is the revolutionary followspot with full electronic control. All functions are at the operator's fingertips. Effects can be controlled by the console, powered directly from the projector or by remote DMX 512. DMX 512 control allows shows to consistently synchronize cues using multiple followspots. The main features of Tracer (power, versatility and overall compact size) have been carefully optimized to maximize performance. The unique main "Tracer" function allows for precise beam positioning with accuracy and confidence.



VERSILE
Total control of an extensive array of functions for use in small and large venues.

COMPACT
Small body design encompasses the latest in optical projection, mechanical and electronic technologies.

POWERFUL
Quality engineered optics coupled with high output metal halide lamp, produce extraordinary light output.

Specifications: Selectable beam angle for different throw distances: 10.5°, 12°, 14° to 16°
 ■ 1200w metal halide 5600°K lamp ■ 7 dichroic colors plus open producing 24 color combinations ■ Color wheel rainbow rotation effect ■ Bi-color splits ■ Color temperature correction filters: 3200°K and 6000°K ■ Linear motorized mechanical dimming from 0-100% ■ Variable speed strobing and black-out shutter ■ Motorized focus ■ Tracer function ■ Gobo wheel with 4 M-Size patterns ■ Typical throw distance: 16 to 175 feet ■ Motorized iris aperture ■ 3-pin and 5-pin XLR in/out data connectors ■ External main electrical fuse ■ DMX 512 using 5 channels ■ Dip-switch DMX addressing ■ LED status indicator ■ Carrying handles ■ Forced air ventilation ■ Lamp: MSR1200 or HSR1200 ■ Lamp life: average 800 hours ■ Power factor correction ■ Internal ballast ■ Power: 208-230vAC at 50/60Hz ■ Current draw: 7.3 Amps ■ Size: 35"x17"x10" ■ Weight: 40Kgs/89Lbs

Specifications are subject to change without notice.



NEWTON FS-NEWTON



The Newton 1200 intelligent follow spot is based on the sophisticated, reliable and well-proven technology of SGM Galileo fixtures. It is designed for professional medium-to-long throw use in theater, television studios and concerts applications, although its user friendliness makes it suitable for any use. This follow spot can be used where automatic or multiple synchronized follow spots need to be on set cues. Using DMX, a lighting designer can produce a controlled cue list and have multiple follow spots responding to a centralized console. Manual control is offered using a separate Newton controller. It mounts next to the follow spot where adjustment vibrations do not affect the light beam while in operation. It is constructed of rugged die-cast and extruded aluminum, however it remains as manageable as possible, with two handles on the sides and a grip on the rear panel. On the rear panel there is also a built-in settings panel with a display. Operators can get information on the follow spot's status, DMX addressing, and fixture and lamp operating times.

Specifications: HMI 1200/GS discharge lamp ■ Lamp life: 750 hours ■ 7 easily replaced standard colors ■ Two-tone beams ■ Adjustable speed rainbow effect ■ Automatic color change with adjustable crossover time ■ High-speed color changer (0.06 sec.) ■ Strobe 0.5 -12 flashes per second ■ Iris ■ Manual focus control ■ 0-100% dimmer ■ DMX512 or RS-232 input signal ■ Built-in microcomputer with display for setting fixture functions and checking status for important information ■ Power supply requirements: 220/240vAC 50/60Hz ■ Controllable via dedicated Newton Control unit or other control desk with DMX 512 or RS-232 ■ Newton Control's special mounting system is built with telescopic stainless steel tubes with adjust-

ment and multi-direction rotation through 360° ■ Dimensions: Newton 1200: 8.3"x 45.1"x 11.4" Newton Control: 2.6"x15.8"x11.2" ■ Weight: Newton 1200: 23Kg/50.7Lbs Newton Control: 4 Kgs/8.8 Lbs

Tripod stand sold separately. See page 50.

TR-NEWTONSTAND A professional 2-section telescopic stand in die-cast aluminum and stainless steel tubing that is in compliance with European safety norms can be purchased separately.
FS-NEWTONLENS Long Throw Lens

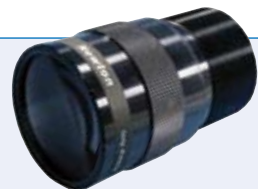

ARENA SERIES

Tripod stand sold separately. See page 50.

Specifications are subject to change without notice.



Followspot MSR1200 FS-ARENA1200M

Specifications: Lamp: MSR1200/2 - 110,000 lux ■ Lamp life: average 800 hours ■ Typical Throw: 30 - 150 feet ■ High quality dual lens system ■ Efficient 68mm glass reflector ■ Zoom adjustment: 10 - 18 degrees ■ Adjustable focus ■ 4 Shaping blades included ■ Mechanical shutter/dimmer ■ Blackout iris included ■ Color frame 7.25"x7.25" included ■ Rear handle & side bar grip area ■ Quiet 49dB operation ■ Extruded aluminum & steel plate body ■ External ballast power supply ■ Output selector: 575w or 1200w ■ Rating: IP20 ■ Power input: 117vAC 50/60Hz ■ Current draw: 10 amps ■ Fixture size: 40.6"x13.15"x10.79" ■ Ballast size: 20.6"x9.1"x9.4" ■ Fixture weight: 17Kgs/37.5Lbs ■ Ballast weight: 25Kgs/55.12Lbs ■ Color: Black powder coat paint ■ **FS-ARENACC** - 5 Color Changer for gel ■ Options: **GOBO-HOLDF SAR-B** Gobo Holder - B size



Followspot I200 FS-ARENA1200T

Specifications: Lamp: 71-2529 CP90 1200W 120v - GX9.5 30,800 lux ■ Lamp life: average 150 hours ■ Typical Throw: 25 - 85 feet ■ High quality dual lens system ■ Efficient 68mm glass reflector ■ Zoom adjustment: 10 - 18 degrees ■ Adjustable focus ■ 4 Shaping blades included ■ Mechanical Shutter/Dimmer ■ Color frame 7.25"x7.25" included ■ Blackout iris included ■ Rear handle and side bar grip area ■ Quiet 49dB operation ■ Extruded aluminum and steel plate body ■ Rating: IP20 ■ Power input: 117vAC 50/60Hz ■ Current draw: 11 amps ■ Size: 40.6"x13.15"x10.79" ■ Weight: 20.5Kgs/45.1Lbs ■ Color: Black powder coat paint ■ **FS-ARENACC** - 5 Color Changer for gel ■ Options: **GOBO-HOLDF SAR-B** Gobo Holder - B size



Followspot MSR575 FS-ARENA575M

Specifications: Lamp: MSR575/2 - 49,000 lux ■ Lamp life: average 1000 hours ■ Typical Throw: 30 - 100 feet ■ High quality dual lens system ■ Efficient 68mm glass reflector ■ Zoom adjustment: 10 - 18 degrees ■ Adjustable focus ■ 4 Shaping blades included ■ Mechanical shutter/dimmer ■ Blackout iris included ■ Color frame 7.25"x7.25" included ■ Rear handle & side bar grip area ■ Quiet 49dB operation ■ Extruded aluminum & steel plate body ■ External ballast power supply ■ Rating: IP20 ■ Power input: 117vAC 50/60Hz ■ Current draw: 6 amps ■ Ballast size: 20.6"x9.1"x9.4" ■ Fixture weight: 17Kgs/37.5Lbs ■ Ballast weight: 22Kgs/48.4Lbs ■ Color: Black powder coat paint ■ **FS-ARENACC** - 5 Color Changer for gel ■ Options: **GOBO-HOLDF SAR-B** Gobo Holder - B size



Followspot MSD250 FS-ARENA250M

Specifications: Lamp: MSD250/2 - 18,000 lux ■ Lamp life: average 2000 hours ■ Typical Throw: 10 - 50 feet ■ High quality dual lens system ■ Efficient 55mm glass reflector ■ Zoom adjustment: 10 - 28 degrees ■ Adjustable focus ■ 4 Shaping blades included ■ Color frame 5.9"x5.9" included ■ Blackout iris included ■ Dual handles for easy operation ■ Extruded aluminum and steel plate body ■ Internal ballast ■ Rating: IP20 ■ Power input: 117vAC 50/60Hz ■ Current draw: 4 amps ■ Size: 28.62"x14.8"x8.7" ■ Weight: 16Kgs/35.2Lbs ■ Color: Black powder coat paint ■ Options: **GOBO-HOLDF SAR2-M** Gobo Holder - M size, **FS-ARENA250CC** - 5 Color Changer for gel

Color Changer
FS-ARENA250CC
Optional 5 Color Changer for **FS-ARENA250M** Follow Spot



PA-PIN46BLK
Par46 pin-spot with 3 prong grounded plug. Black color finish and screw on front cap. Produces very narrow shaft of light. Includes 4535 6v/30w lamp. Weight: 1.4Kgs/3Lbs



PA-PIN36BLK/C
Pin-Spot 36 with a rotating 4-color 9" diameter wheel. Colors are red, yellow, green, and blue. Comes with 30w 6v 4515 lamp. Rotates at 1-2RPM. Size: 11.8"x9"x9.8" ■ Weight: 2.1Kgs/4.6Lbs



PA-PIN36BLK
Quality pin-spot Par36 with screw on front cap and Edison (3 prong) grounded power cord. Comes with 30w 6v 4515 lamp. Black finish. Color lens optional. Weight: 1.1Kgs/2.5Lbs



PA-PIN36OSC1
Oscillating pin-spot effect. Sweeps side to side 180 degrees. Comes with 30w 6v 4515 lamp. Black finish. Color lens optional. Size: 6.4"x6.4"x11.4" ■ Weight: 1.4Kgs/3.1Lbs

PA-PIN36BLKUL U.L. approved version.

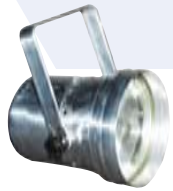

PA-PIN36P
Quality polished aluminum pin-spot for par 36 lamp with ring front clip and grounded power cord. Comes with 30w 6v 4515 lamp. Polished finish. Color lens optional. Weight: .91Kgs/2.0Lbs



PA-LENS36X
PA-LENS46X
Plastic lens covers for pin-spots Par36 and Par46. Available in Amber, Aqua, Blue, Green, Magenta, Purple, Pink, Red, Yellow. X specifies color when ordering.

ColorRGB Flood Wash

IL-COLORRGB



The ColorRGB incorporates RGB color mixing into a single fixture with wide dispersion. It has the ability to create virtually any color combination. Using a DMX controller, both color and intensity may be altered. Great for washing wide areas with color, for backgrounds and stage highlights.

Specifications: Built in 3 channel dimming system, no additional dimmers needed ■ Red, Green, and Blue dichroic filters ■ Digital display addressing ■ X 40 by Y 60 degree beam spread ■ 2 or 3 channel DMX input operation via XLR ■ 0-100% dimming ■ Lamp sources include 3 x EHM 300w or 3 x FCL 500w ■ Power: 120vAC 50/60Hz ■ Current Draw: 13 Amps ■ Size: 15.6"x10"x6.7" ■ Weight: 6.8Kgs/15Lbs ■ Color: Black powder coat paint finish



IL-COLORRGB/B
Optional: 4 Leaf Barndoor

COLOR BLASTER 250

IL-COLOR1

The Color Blaster 250 delivers a wide, hard edged beam of rich dichroic color. Features include ten dichroic colors plus white, strobe and 0 - 100% dimming. Run it in automatic music mode to enjoy a pre-programmed show or DMX control from any DMX-512 controller. Select either mode with the flip of a dip switch. Self test function and DMX signal termination. With the Color Blaster you get an easy to use color changer that can serve many lighting applications.

Specifications: ELC 250w 24v lamp ■ Power: 120vAC 50/60Hz ■ Power Consumption: 300W ■ 10 dichroic colors + white ■ Rainbow effect; shutter and dimming ■ 1-5 fps Strobe ■ 2 DMX Channels: 1-color/shutter, 2-dimmer ■ Large optical path ■ Audio Control ■ 3-pin XLR Connectors ■ Standard DMX512 control and address ■ Electronic dimming 0-100% ■ Size: 11"x5.9"x6.1" ■ Weight: 6.3 Kgs/14Lbs



Par-Cans

Manufactured from high quality spun aluminum and supplied with an octagonal gel frame holder and lamp socket. Our par-cans incorporate a unique clutch locking device which is designed to take the additional load of a color changer. The single handed action enables minute adjustment without the need for tools. Heavy duty yokes and steel reinforced rivets withstand touring and rental applications. All par-cans are available in either black or polished. Lamps or reflector kits sold separately.

X= Polished or Black

Par-Can Accessories & Parts



X denotes various specifications needed for correct part selection.

LONG AND SHORT PAR CANS - High quality and heavy duty spun 2mm aluminum, with 4th clip, gel frame, GX16d socket, cable gland, protection screen, clutch brake, lamp retention ring, and 3ft power cable with Edison plug. X specifies color in Polish or Black finish in order code. Lamps sold separately.

PA-PAR64LX LONG PAR CAN Available in Polish, Black or White - U.L. approved.

PA-PAR64SX SHORT PAR CAN - Polish or Black Body similar to long par can - Not U.L. approved.

PA-PAR56LX Available in long: Polish, Black or White. Black and polish are U.L. listed

PA-PAR46LX Available in long: Polish or Black

PA-PAR20XX Available in long: Polish, Black or White Available in short: Polish Both available with E26 medium screw in socket.



PA-PAR38X High quality spun aluminum. Includes: 4th clip, gel frame, E26 medium screw in base, cable gland, and power cable with Edison plug. Can be used with a variety of screw base par or reflector lamps. X specifies Polish or Black finish in order code. U.L. approved.

PA-BARNDOOR20B 4 leaf barn doors for Par 20 Black
PA-BARNDOOR56B 4 leaf barn doors for Par 56 Black
PA-BARNDOOR64X 4 leaf barn doors for Par 64, X= Polished or Black

PA-PAR4THCLIPP 4th spring loaded clip for Par 46, 56, 64 polished

PA-FRAME##X Octagonal gel frames for Par 16, 20, 38, 46, 56, 64, Polished or Black

PA-PAR##RING Lamp retaining ring for Par 46, 56, 64

PA-PARBLOCK 4 screw ceramic terminal block

PA-PARCAPKNOB Par can cap knob & spring fastener

PA-PARKNOB Side knob for Par 46, 56, 64

PA-PARSTRAIN Par can strain relief-black

PA-POWERCORD1 Power Cord 14AWG/6ft w/plug

PA-POWERCORD2 Power Cord 18AWG/6ft w/plug

PA-POWERCORD3 High Temp Par Power Cable 2ft

PA-RF##M Medium flood reflector kit for Par 56, 64

PA-RF##N Narrow flood reflector kit for Par 56, 64

PA-RF64W Wide flood reflector kit for Par 64

ZELS0037 Socket for Par 46, Medium Side Prong

ZELS0038 Socket for Par 64 & Par 56, GX16d



PA-PAR16E17X Par 16 Can with E17 lamp socket, gel frame and power cord. X specifies color in Polish or Black finish in order code. **75 WATT MAXIMUM USAGE**

Specifications are subject to change without notice.

FlexiPar

PA-FLEXIPAR/B Black
PA-FLEXIPAR/W White

The FlexiPar is an attractive aluminum die-cast PAR lighting fixture with selectable beam angle lenses and adjustable yoke. Its special reflector produces an output which exceeds traditional par-cans using higher wattage lamps. Reduces power consumption and dimmer distribution. Four interchangeable glass lenses are included to easily vary the light beam width from Wide, Medium, Narrow to a Very Narrow. Includes one 7.5"x7.5" gel frame and power cord. Power plug sold separately.



Specifications: Lamp: FLK 575 ■ Power: dependent on lamp, 120vAC-230vAC 50/60Hz ■ Current draw: FLK 575 at 4.8 Amps ■ Size: 11.5"x10"x8.5" ■ Weight: 3.4Kgs/7.48Lbs

FlexiPar Spare lenses: glass 7" diameter



PA-FLEXIPARLM
Medium Flood,
12x19°



PA-FLEXIPARLW
Wide Flood,
16x33°



PA-FLEXIPARLN
Narrow Beam, 10°



PA-FLEXIPARLVN
Very Narrow
Beam, 8°

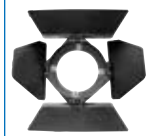

FlexiBarndoor

PA-FLEXIBARNDOOR

Specifications:
18.5"x18.5"x1/5" ■ 1.134Kgs/
2.5Lbs ■ Color: Black



FlexiFrame

PA-FLEXIFRAME/B

Specifications: 7.5"x7.5"x0.125" ■
0.154Kgs/0.34Lbs ■ Color: Black

FlexiTool

PA-FLEXITOOOL

Great tool for quick and
easy removal of flexipar lenses.

Specifications: 4"x1.5"x0.25" ■ 0.023 Kgs/
0.05Lbs ■ Color: Black



ParBars

Par bars are designed for concert, stage and touring applications where quick par can set-ups and tear-downs are essential. Available in several electrical configurations. May be used with Par 64, Par 56 and Par 46 Cans. Polished aluminum 2" pipe with silicon cable wiring.



PD-PARBAR4/1P

For use with four par cans wired in series, using ACL 28v type lamps ■
Power input: silicon cable ■ Length: 5 feet ■ Weight: 3Kgs/6.6Lbs



PD-PARBAR4/4P

For use with four par cans wired to 4 individual circuits ■ Power input: 19
pin connector ■ Length: 5 feet ■ Weight: 3Kgs/6.6Lbs



PD-PARBAR6/6P

For use with six par cans wired to 6 individual circuits n Power input: 19
pin connector ■ Length: 7.5 feet ■ Weight: 5Kgs/11Lbs

ULTRALIGHT 36

DL-ULTRALIGHT36

Specifications: 12 High Power 3 Watt Edison LEDs ■ Light Output: 1600 Lux at 1 meter, 440 Lux at 2 meters ■ 400Hz Flicker free video friendly ■ Control: Local (manual) dimming (0-100%) ■ Color temperature: 5600K° ■ Beam Angle: 45° lenses ■ Accessory frame and barndoors included ■ Power: 110v-240vAC 50/60hz ■ Power consumed: 40 Watts ■ Size: 4.2"x6.3"x7.5" ■ Weight: .95Kgs/2.1Lbs ■ Color: Black/Orange

Optional Accessories:

Dichroic color filter: CTO (5600K° to 3200°)
Stand sold separately.



ULTRALIGHT 60

DL-ULTRALIGHT60

Specifications: 20 High Power 3 Watt Edison LEDs ■ Light Output: 3000 Lux at 1 meter, 340 Lux at 3 meters ■ 400Hz Flicker free video friendly ■ Control: Local (manual) dimming (0-100%) ■ Color temperature: 5600K° ■ Beam Angle: 45° lenses ■ Accessory frame and barndoors included ■ Power: 110v-240vAC 50/60hz ■ Power consumed: 65 Watts ■ Size: 6.7"x8.5"x10.4" ■ Weight: 3.2Kgs/7.1Lbs ■ Color: Black/Orange

Optional Accessories:

Dichroic color filter: CTO (5600K° to 3200°)
Stand sold separately.



STUDIO LED WASH 48

DL-STUDIOLED48B

Specifications: 48 LEDs High Power 1 Watt Edison ■ Color temperature: 48 leds 5600K° or 24 leds 5600K° and 24 leds amber ■ Light Output: 2800 Lux at 1 meter, 760 Lux at 2 meters, 360 Lux at 3 meters ■ Beam Angle: 45° lenses ■ Accessory frame ■ 400Hz Flicker free video friendly ■ Control: DMX & Local (manual) dimming (0-100%) ■ DMX In/Out: 5 Pin XLR ■ DMX Settings using display and 2 push buttons ■ Power: 110v-240vAC 50/60hz ■ Power consumed: 52 Watts ■ Size: 11.02"x4.33"x9.45" ■ Weight: 1.8 Kgs/3.97Lbs ■ Color: Black

Optional Accessories:

Color and Diffussion filters
Stand sold separately



DL-STUDIOLED48B
shown with CTO
Filter to 3200K



DL-STUDIOLED48B
shown with
Diffusion Filter



Fresnels

TF-FRESNEL SERIES

The fresnel series ranges from 300 watt to 5000 watt fixtures. All units come complete with mounting yoke, color frame, barn-doors and adjustable beam spread. Lamp and power plug sold separately.

- TF-5001:** Lens 3" diameter ■ 300 watt ■ Lamp base GY9.5 for FKW lamp ■ Beam adjustable from 16 to 60 degrees ■ Weight: 2.5Kgs/5.5Lbs
- TF-5002:** Lens 5" diameter ■ 650 watt ■ Lamp base GY9.5 for FRK or FRG lamps ■ Beam adjustable from 16 to 60 degrees ■ Weight: 3.6Kgs/8Lbs
- TF-5003:** Lens 6" diameter ■ 1000 watt ■ Lamp base G22 for EGT or EGN lamps ■ Beam adjustable from 9 to 55 degrees ■ Weight: 7.7Kgs/17Lbs
- TF-5004:** Lens 10" diameter ■ 2000 watt ■ Lamp base G38 for CYX lamp ■ Beam adjustable from 9 to 45 degrees ■ Weight: 12.7Kgs/28Lbs
- TF-5005:** Lens 12" diameter ■ 5000 watt ■ Lamp base G38 for DPY lamp ■ Beam adjustable from 12 to 57 degrees ■ Weight: 19.5Kgs/43Lbs

Lamp types listed are for 120vAC. Different lamp types required for 230vAC operation. Dimensions & photometric data are available upon request.

CYC SERIES

These cyclorama lights feature asymmetrical reflectors and can support a variety of wattages ranging from 100 to 1000 watts. Each unit compartment requires one power circuit each. All cyc lights include color frame and R7s lamp socket. Lamps sold separately.

Iris Cyc available in single unit or set of four. Use 168-189mm lamps

TF-5321: Single unit with yoke ■ Weight: 7.8Kgs/17.2Lbs ■ Size: 21"x16.5"x9.1"

TF-5324: Quad unit with yoke ■ Weight: 31Kgs/68Lbs ■ Size: 70"x16.5"x9.1"

Ground & Sky focusable versions come in single units which can be combined in groups to form banks. Use 118mm lamps



TH-5380G: Ground single unit ■ Weight: 5.9Kgs/13Lbs ■ Size: 11.8"x11.8"x8.7"

TH-5380S: Sky single unit with yoke ■ Weight: 6.4Kgs/14.1Lbs ■ Size: 15.75"x19"x8.7"

Use different lamp types for 230v. Dimensions & photometric data are available upon request.



MINILUZ 1000

TF-5303

MiniLuz 1000 includes barn doors. Maximum horizontal beam angle of 63 degrees. Lamps sold

separately. Use FCM or FHM lamp for 1000 watt operation or FDN for 500 watt.

Weight: 1.6Kgs/3.5Lbs

Uses different lamp types for 230v. Dimensions & photometric data are available upon request.

RIBALTA SERIES Stage Light Cyc Series

The Ribalta is the ideal choice when you need a bright, even wall or cyc wash. Ribaltas are available with either symmetrical or asymmetrical aluminum reflectors. The fixtures may be lamped from 250 to 750 watts using double ended linear halogen 119mm R7s bulbs. All units come complete with mounting yoke, and color frames. Lamps and power plugs sold separately.



Symmetrical reflector:

TH-RIBALTAS1 Single head ■ Size: 11"x11.93"x5.67" ■ Weight: 2Kgs/4.41Lbs

TH-RIBALTAS4 Four head ■ Size: 40.6"x11.93"x5.67" ■ Weight: 6.6Kgs/14.6Lbs

Asymmetrical reflector:

TH-RIBALTAA1 Single head ■ Size: 11"x11.93"x5.67" ■ Weight: 2Kgs/4.41Lbs

TH-RIBALTAA4 Four head ■ Size: 40.6"x11.93"x5.67" ■ Weight: 6.6Kgs/14.6Lbs

MiniBrut TF-6002 is also available in several other sizes. Most popular is 6 lamp unit shown. Can be used for stage blinding effect or T.V. & film studio general lighting. Uses DWE 650w lamps sold separately. Side leaf doors included. Weight: 8.62Kgs/19Lbs

Uses different lamp types for 230v. Dimension & photometric data are available upon request.



STRIP LIGHTS

MR16 strip lights. Available in 10 lamp or 20 lamp set. Choice of either 50 or 75 watt lamps and various beam angles. Lamp options: EXZ, EXN, EYF, EYC. Lamps sold separately.

TH-5340-10 lamp

Size: 7.9"x45.3"x11.8" ■ Weight: 13Kgs/28.7Lbs

TH-5341-20 lamp

Size: 7.9"x53.2"x11.8" ■ Weight: 16.3Kgs/35.3Lbs



BANK LIGHTS

Par 36 bank lights, also known as punch lights, perform as audience blinders and as bang lights in stage shows. Protective metal grill over each lamp. Available in 4 or 8 lamp sets with mounting yoke. Internal wiring must be completed by user. Use with Par 36 DWE 650 watt lamps sold separately. Body finish in black powder coat paint.



TH-BANK4: Power: two power cords with Edison plugs ■ Size: 18"x20"x4.5" ■ Weight: 5.2Kgs/11.4Lbs

TH-BANK8: Power: four power cords with Edison plugs ■ Size: 18"x27"x4.5" ■ Weight: 9Kgs/19.8Lbs



LEO ELLIPSOIDAL SPOTLIGHT

LEO (Leviton's Enhanced Optics) ellipsoidal spotlights are used for hard edge beam shaping and pattern/gobo projections. These ellipsoidals are available in 5 different beam angles: 15, 19, 26, 36, & 50 degrees. All units include mounting yoke, color frame, shaping blades and a leviton c-clamp. Cast aluminum construction. Additionally, the LEO features an industry exclusive repositionable lens, enabling the user to change field angles, in the field, in the same barrel! Gobo pattern holder and lamp sold separately.

Additional photometrics information available at www.techni-lux.com

Features:

- Continuous Body and Barrel on Axis Rotation (greater than 360°)
- Up to 750w Lamp
- Operating power of 115 & 230 volts with lamp selected
- Cosine (Flat) and Peak Focus with all Recommended Lamps and Beam Angles
- 30 Second Lamp Replacement
- Field Adjustable Lenses to Change Field Angle
- Cool Grip Handles for all Common Adjustments

TH-LEO15

Specifications: Beam angle: 15 degree lens barrel ■ Heavy stainless steel shutters in a quad-plane assembly ■ Two industry standard size accessory slots ■ Supports glass or steel gobos, Size A or B (3" gate) ■ Faceted glass reflector with dichroic coating ■ Power: depends on lamp 115-240vAc 50/60hz ■ Rating: UL Listed ■ Size: 27"x16.25"x8.4" ■ Weight: 7.7Kgs/17Lbs ■ Color: Powder Coated Black

TH-LEO19

Specifications: Beam angle: 19 degree lens barrel ■ Heavy stainless steel shutters in a quad-plane assembly ■ Two industry standard size accessory slots ■ Supports glass or steel gobos, Size A or B (3" gate) ■ Faceted glass reflector with dichroic coating ■ Power: depends on lamp 115-240vAc 50/60hz ■ Rating: UL Listed ■ Size: 27"x16.25"x8.4" ■ Weight: 7.7Kgs/17Lbs ■ Color: Powder Coated Black

TH-LEO26

Specifications: Beam angle: 26 degree lens barrel ■ Heavy stainless steel shutters in a quad-plane assembly ■ Two industry standard size accessory slots ■ Supports glass or steel gobos, Size A or B (3" gate) ■ Faceted glass reflector with dichroic coating ■ Power: depends on lamp 115-240v 50/60hz ■ Rating: UL Listed ■ Size: 27"x16.25"x8.4" ■ Weight: 7.7Kgs/17Lbs ■ Color: Powder Coated Black

With the lenses included in this 26 degree fixture, you may convert it to a 19 or 36 degree without purchasing any additional lenses.



TH-LEO36

Specifications: Beam angle: 36 degree lens barrel ■ Heavy stainless steel shutters in a quad-plane assembly ■ Two industry standard size accessory slots ■ Supports glass or steel gobos, Size A or B (3" gate) ■ Faceted glass reflector with dichroic coating ■ Power: depends on lamp 115-240vAc 50/60hz ■ Rating: UL Listed ■ Size: 27"x16.25"x8.4" ■ Weight: 7.7Kgs/17Lbs ■ Color: Powder Coated Black

With the lenses included in this 36 degree fixture, you may convert it to a 19 or 26 degree without purchasing any additional lenses.

TH-LEO50

Specifications: Beam angle: 50 degree lens barrel ■ Heavy stainless steel shutters in a quad-plane assembly ■ Two industry standard size accessory slots ■ Supports glass or steel gobos, Size A or B (3" gate) ■ Faceted glass reflector with dichroic coating ■ Power: depends on lamp 115-240vAc 50/60hz ■ Rating: UL Listed ■ Size: 27"x16.25"x8.4" ■ Weight: 7.7Kgs/17Lbs ■ Color: Powder Coated Black



TH-5016



TH-5017



Dichroic Glass Reflector



ELLIPSOIDALS WITH ZOOM

Used for hard edge beam shaping and pattern/gobo projections. These ellipsoidals have variable beam angle zoom. All units come complete with mounting yoke, color frame, shaping blades and "B" size pattern holder. Built from weight extruded aluminum and die-cast parts. Uses new optical dichroic reflector technology which produces more light output and consumes less energy than conventional 1000w ellipsoidals. Lamp and power plug sold separately. Lamp base G9.5. For 120v: use 575 watt GLC or extended life GLA lamp type. For 230v: use 600 watt GKV or extended life GLB lamp type. Add W to code for white. Options, dimensions & photometric data are available upon request.

TH-5016: Zoom adjustable from 15 to 30 degrees ■ Size: 23.24"x10.24"x13" ■ Weight: 6.8Kgs/15Lbs

TH-5017: Zoom adjustable from 25 to 50 degrees ■ Size: 23.24"x10.24"x13" ■ Weight: 6.8Kgs/15Lbs

FL-Series Fluorescent Cool Lights

Dexel offers a full line of fluorescent fixtures suitable for both studio and location lighting. Fluorescent fixtures produce more lumens per watt than conventional tungsten incandescent fixtures resulting in less heat emission, less power consumption and savings on cooling costs. All Dexel Fluorescent fixtures come with louver and intensifier accessories at no extra cost. Specify Color temperature of 3200 degrees Kelvin to match conventional incandescent fixtures or 5600 degrees Kelvin to match natural or artificial daylight fixtures.

DMX technology makes it possible to integrate the Dexel Fluorescent units into a digitally controlled lighting system. Using DMX control, multiple units can be wired into a network with low voltage wiring and controlled from a digital console. A local/DMX selector allows operation by potentiometer or DMX control. All DMX fixtures have manual dimming controls local at the fixture without external DMX control. All units are 100% flicker-free with electronic ballasts.

Photo metrics and additional specifications are available upon request.
All fluorescent fixtures below do not include lamps, power plugs or clamps. Items sold separately.

Luz Fria Studio (Studio Cool Lights) are ideal for studio use and come complete with intensifier. The Studio version is also available with the pole operation feature. Use for high quality soft light or combine with quartz-halogen fresnels for an entire studio set-up. Typical applications include fill light, soft-key, back light, Chromakey and Ultramatte cyc lighting and virtual studios.



Code	Description	Lamp Types
FL-LFS2/55	Softlight 2x55w with DMX/Local dimming 120v-230v Size: 29.55"x10.63"x12.80" ■ Weight: 10.5Kgs/23.15Lbs	F55BXCIN3200 or 5600
FL-LFS4/55	Softlight 4x55w with DMX/Local dimming 120v-230v Size: 30.33"x12.41"x17.33" ■ Weight: 15.5Kgs/34.17Lbs	F55BXCIN3200 or 5600
FL-LFS4/55P	Softlight 4x55w Panoramic with DMX/Local dimming 120v-230v Size: 53.97"x10.63"x14.26" ■ Weight: 21Kgs/46.3Lbs	F55BXCIN3200 or 5600
FL-LFS6/55	Softlight 6x55w with DMX/Local dimming 120v-230v Size: 31.12"x16.94"x22.85" ■ Weight: 18Kgs/39.7Lbs	F55BXCIN3200 or 5600

Power Flo is the ideal lightweight solution for video and film location lighting. High output and low current draw works well on locations with limited power options. Available with standard household "Edison" style plug, these units work well where circuit over-loading is a problem. Equipped with lamps with a CRI of 95, colors respond to the special sensitivity curves of modern film stocks and high-definition electronic media.



Code	Description	Lamp Types
FL-DFL2/20	PowerFlo 2x20w with DMX/Local dimming 120v-230v Size: 28.37"x12.61"x13.00" ■ Weight: 5Kgs/11.02Lbs	F20T12CIN3200 or 5500
FL-DFL2/40	PowerFlo 2x40w with DMX/Local dimming 120v-230v Size: 52"x12.61"x13.00" ■ Weight: 10Kgs/22.05Lbs	F40T12CIN3200 or 5500
FL-DFL2/55	PowerFlo 2x55w with DMX/Local dimming 120v-230v Size: 26"x12.09"x12.84" ■ Weight: 4.5Kgs/9.92Lbs	F55BXCIN3200 or 5600
FL-DFL4/20	PowerFlo 4x20w with DMX/Local dimming 120v-230v Size: 28.37"x14.97"x14.97" ■ Weight: 7Kgs/15.43Lbs	F20T12CIN3200 or 5500
FL-DFL4/40	PowerFlo 4x40w with DMX/Local dimming 120v-230v Size: 52"x14.97"x14.97" ■ Weight: 13Kgs/28.66Lbs	F40T12CIN3200 or 5500
FL-DFL4/55	PowerFlo 4x55w with DMX/Local dimming 120v-230v Size: 26"x14.02"x14.33" ■ Weight: 6.5Kgs/14.33Lbs	F55BXCIN32 or 5600

The Power Bank offers lightweight but rugged aluminum construction and can be mounted in either a horizontal or vertical orientation. It is supplied with a mounting plate and support for lighting stands, or it can be mounted directly on the wall or ceiling for a more permanent installation. The lamps of the Power Bank can be controlled remotely from a ballast box using the control panel. Silver focusing louver included to help control the spread and direction of light.

The following fluorescent banks supplied with mounting plate, louver, extension cable, ballast & control panel.

Code	Description	Lamp Types
FL-PB320	Power Bank 8 Lamp 40w with DMX/Local dimming Size: 49.21"x11.8"x23.6" ■ Weight: 5Kgs/11.02Lbs	F40T12CIN3200 or 5500
FL-PB400	Power Bank 10 Lamp 40w with DMX/Local dimming Size: 49.21"x11.8"x27.5" ■ Weight: 6Kgs/13.23Lbs	F40T12CIN3200 or 5500



Fluorescent Power RGB

FL-PRGB4/54B
 Full color mixing fluorescent fixture for cyclorama lighting, chromakey (blue or green), stages, and other architectural light effects. Intensity control of each lamp from 0-100 %. Uses energy saving and long life (20,000 hours) fluorescent lamps.

Specifications: Lamps 4x54w Red, Green, Blue, White ■ 4 Channel DMX 512 ■ 5 pin XLR input ■ Power: 120vAC-230vAC 50/60Hz ■ Current draw: 2 Amps ■ Size: 50"x6.7"x20.9" ■ Weight: 13.5Kgs/29.8Lbs

Specifications are subject to change without notice.

REGIA 2048 CONSOLES

SGM Regia 2048 lighting control consoles are extremely popular with lighting operators and designers throughout the world for their versatility, ease of use and reliability. SGM consoles combine a clear user-friendly control panel and a constantly updated operating system with stylish and sturdy hardware. SGM lighting control consoles - just switch them on and you're ready to start working: with just a glance you can check the status of any moving head fixture, scanner, color-changer, dimmer or conventional fixture. Each unit's control panel has numerous functions but is extremely user-friendly: the various work areas are clearly indicated and the controls are laid out in a logical manner, for precise effective programming of a single effect or an entire show. SGM lighting consoles take all the complexity out of typical professional lighting controls, allowing lighting designers to concentrate entirely on creativity. All Regia consoles are supplied in a roadcase.



INFOCOMM,
Orlando FL



LIVE
CT-REGIA2048L



OPERA
CT-REGIA2048O



PRO
CT-REGIA2048P



Monitors **not** included

All Regia 2048 model specifications:

- Interchangeability from one model to the other
- 2048 DMX channels
- 4 Independent DMX lines
- Includes WYSIWYG Console Edition (PC required)
- Shape engine
- Personalities library for all major fixture models
- Self creation of fixture profiles
- Fast access to groups, fixtures, palettes
- Unlimited multi-part cues
- Motorized A & B masters
- Track ball / Mouse
- 4 Encoders
- 11 Function keys
- PC mouse & keyboard input
- Built-in CD-RW drive
- Built-in Hard Disk
- 3.5" Disk drive
- RS-232 Out
- Printer Out
- MIDI In / Out / Thru
- SMPTE In
- Ethernet connection
- 2 External SVGA video ports
- Internal UPS power backup built-in
- Internal data back up
- Power input via Neutrik PowerCon connector
- Power: auto sensing 90-250vAC-50/60Hz

Regia 2048 Pro
CT-REGIA2048P

-
-
-
24 Playback Registers
Size: 27.2"x22.25"x6.5"
Weight: 24Kgs/52.8Lbs

Regia 2048 Opera
CT-REGIA2048O

-
-
96 Manual Presets
24 Playback Registers
Size: 47.2"x22.25"x6.5"
Weight: 35Kgs/77Lbs

Regia 2048 Live
CT-REGIA2048L

1x12" Touch Screen monitor
1x12" TFT monitor
24 Manual Presets
12 Playback Registers
Size: 41"x22.25"x7.9"
Weight: 37Kgs/81.4Lbs



WYSIWYG by Cast software is the industry standard lighting design and simulation software. WYSIWYG will provide paperwork, renderings, photometrics and layout for virtually all lighting products. An entire suite of software and hardware is available from Techni-Lux. WYSIWYG CE consoles can also be upgraded to full release versions.

CT-WYSIWYG-D Design edition - Full design suite and library including rendering and layout

CT-WYSIWYG-P Perform edition - All of the features of Design edition plus console compatibility

PILOT 3000
CT-PILOT3000



PILOT 2000
CT-PILOT2000



Pilot 2000 is an extremely versatile universal DMX controller, ideal for a vast range of applications: from concerts to theatre, clubs to television studios, small to large show events. Compact, but with the performance of a large desk, Pilot 2000 controls 512 freely configurable DMX channels. Pilot 2000's clear, user-friendly control panel ensures a simple, direct and plain English approach to programming. Logical operating areas and easily accessible controls make the board perfect for live operation. Easily control intelligent fixtures with dimmers in one work space. Firmware, fixture templates and programs can be added, modified, and saved easily via RS232. A complete series of connections (DMX Out, Audio In, RS-232, SMPTE In and MIDI In/Out/Thru) make the Pilot 2000 a versatile control center for both small and large installations. Pilot 2000 is housed in a 4U rack module, facilitating installation or handy desktop use.

pilot 3000

- Built-in Fixture Library
- Effect Engines
- 1024 DMX Channels
- Color TFT Tough
- 4 Encoder Wheels
- 2" Jog Ball for Pan/Tilt



*Cheyenne Saloon,
Orlando FL*

Specifications: Compact controller with easy to read display for desk top or rack mount ■ 512 DMX channels, up to 40 fixtures 192 dimmer channels ■ Download or create fixture templates containing up to 36 channels ■ Pan/Tilt control with cursor buttons or joystick with axis lock-outs ■ Direct access to lamp, reset and other functions ■ Instant access to 4 x 40 program elements with 20 multifunction buttons ■ Up to 4 program elements can run at the same time with selectable preference ■ Trigger via Time, Tap, 4 selectable bands with Line or int. Mic, SMPTE or MIDI ■ Back-up and update all features and functions via RS-232 ■ DMX out via 5-pin XLR ■ Power: 120/230vAC ■ Current Draw: 2 Amps ■ Size: 2.95"x18.98"x8.75" ■ Weight: 3.8Kgs/8.36Lbs

SMART
CT-SMART



Smart Control is a simple two channel DMX controller that enables the remote control of the main functions of the Flasher DMX 1.5. Smart Control can be used in either manual or automatic mode. In manual mode, pressing the appropriate button sends the values set with two special faders to the corresponding DMX channels of the Flasher DMX 1.5. In automatic mode, the values set with the faders are sent with a frequency and duration programmed using two dedicated potentiometers. **Specifications:** DMX out via 5-pin XLR ■ Power: 9v battery or wall transformer ■ Size: 1.89"x6.65"x2.83" ■ Weight: .45Kgs/1Lbs



PILOT 3000 is a sophisticated DMX controller ideal for controlling large and small lighting systems. PILOT 3000 can control up to 1024 DMX channels via two independent DMX outputs. Using the PILOT 3000 is simplified by the logical layout of its controls and the use of sophisticated facilities, including: Color TFT touch screen for direct access to the functions displayed; 4 encoder wheels for controlling the parameters of the Palettes during editing, programming or for assigning values in the program's various screens; Joy Ball for Pan/Tilt. The on-board software and comprehensive connectors enable major communication protocols (DMX 512, MIDI, SMPTE) to be handled. PILOT 3000 can be connected via Ethernet, and is connected to PCs via a USB port.

Specifications: Powerful graphical user interface for rapid programming and easy control ■ 5.7" color TFT Touch Screen Display monitor with 320X240 resolution ■ Additional LCD rear-lit 80-digit display of fader settings ■ 6 completely configurable scene control faders ■ 1024 DMX Channels on 2 independent ■ XLR 5-Pin lines for control of either automated fixtures or dimmers ■ Independent DMX XLR 5-pin Input ■ 10 programming function keys ■ 20 keys for direct access to playback registers ■ Playback of a max of 20 cue-lists simultaneously ■ Maximum 999 cues for each playback register ■ Maximum number of cues storable per show: 6000 ■ Advanced Shape Effect Engine ■ Personality fixture library, updateable by user ■ 64MB outboard memory on compact flash card ■ 4 encoder wheels for controlling attributes during programming and control of effects during playback ■ Grand Master fader + DBO key ■ Joyball for PAN and TILT control with 'locks' and 'fine' buttons ■ Built-in microphone ■ Two LED light USB ports ■ Aux Input ■ SMPTE Input - 3 Pin XLR ■ MIDI In/Out/Thru - 5 Pin Din ■ Audio Input using 1/4" RTS connector ■ USB connection ■ Connector for Compact Flash drive ■ Power: Universal 85-265v switching power supply ■ Size: 5.31"x19.8"x19.8" ■ Weight: 4Kgs/8.8Lbs



CONTROL 5
CT-CONTROL5



Specifications: Full 512 DMX Channels ■ Store up to 4000 Scenes ■ Scenes can be stored in 100 different programs ■ Up to 40 fixtures can be controlled and five groups of fixtures are available ■ Each parameter can be 8/16 bit resolution ■ 16 faders for manual control ■ controller can be synchronized with an external device by MIDI IN, DMX IN or MUSIC IN ■ An Incremental cloche is available for precision moving head positioning, with associated two buttons to invert each axis (x-inversion, y-inversion) ■ Internal preset can be edited and stored in user memory ■ Direct access to main functions by individual buttons ■ Advanced functions are available by three buttons with dynamical menus ■ Every scene has two timers available (WAIT TIME and FADE TIME) to create the fades from a scene to the next one ■ An immediate numeric keyboard is used to fast recall programs, steps or assign a numeric value to a parameter ■ Flash buttons can be used in a dimmer patch or to assign a specific function to the parameter ■ Firmware upload via DMX line ■ USB connector for DJ work light ■ Power failure memory ■ Power input DC 12.24v, 800mA min. ■ Power supply include ■ Rack mount: 4 Rack spaces ■ Size: 8.66" x20.87"x3.94" ■ Weight: 3.5Kgs/7.72Lbs

Specifications are subject to change without notice.

Artist

Object oriented lighting & show control software



Artist is a multi-role lighting and show controller and is the next generation system to ShowCAD, a controller that has become a standard for the nightclub industry. ShowCAD's flexibility has also enabled it to be installed in many AV, architectural, theatrical, theme park, T.V. and film applications. Artist now pushes the envelope for show design and overall control further still. . .

Objectives From Install to show in quickest possible time ■ Object oriented programming-scenes, fixtures and cues know their identity ■ Access to all operating system resident devices including DVD and video ■ No limit placed on number of DMX output channels ■ No limit on the number of scenes and cues running concurrently

Features Wizards to guide through those first tentative steps ■ Graphical editor to create custom fixture specific templates ■ Instant access focus, color, gobo and beam palettes ■ Sub-scenes ■ Pile add ■ Blind edit ■ Snagging tools soothe the tedious hours of DMX troubleshooting ■ On screen help ■ Powerful LED Matrixing system ■ Full show control and system integration ■ Video to LED mapping and pixilation ■ Integrated SMPTE time-code ■ Real time clocks and timers ■ Plus much more!

The following specifications are for simple single universe installations. For more advanced systems, give us a call.

Minimum specification: 800MHz Pentium or equivalent processor ■ 128MB of RAM ■ Graphics with 1024 X 768 resolution ■ USB for ShowCAD USB-DMX interface ■ Ethernet for ArtNet or Pathport interfaces ■ 40GByte hard disk ■ Microsoft Windows XP or Vista

Recommended specification: 2 Core 2GHz processor ■ 2 GB of RAM ■ Graphics with 1920 X 1200 resolution ■ 2 USB ports ■ Ethernet for ArtNet or Pathport interfaces ■ 100GByte hard disk ■ Microsoft Vista Professional

CT-ARTIST-ML ShowCAD Artist v3 Control Software - Main + 1 DMX Universe License (software only, hardware sold separately)

CT-ARTIST-AL ShowCAD Artist Additional DMX512 Universe License

CT-ARTIST-UP ShowCAD Artist Version Upgrade (download software only)

CT-ARTIST-U (Hardware only, software sold separately.) ShowCAD USB to DMX 512 Channel interface 5 Pin Female ■ Artist Kit includes: USB cable, DMX 5 Pin to 3 Pin Adapter, and converter box ■ Additional boxes may be purchased for multiple sets of 512 channels ■ Size: 3"x3.5"x1.5" ■ Weight: 15Kgs/325Lbs



A Word about Performance The performance of a PC is dependent on the speed of the processor and of the data busses with which it communicates to memory, graphics and disk drives. In fact, these days the speed of the processor is a lot less important than the speed of the communications channel as your experience with the internet will tell you. Laptop computers run their data busses much slower in order to conserve power and therefore, are *unsuitable* for large DMX schemes in excess of 2 universes.



Additional DMX Hardware

Pathport ethernet options available upon request.

Check out the online product demo! <http://www.showcad.com/downloads.shtml>

MC 7524

CT-NSMC7524



Catering to the advanced lighting designer, the 7500 Series features operational modes such as cue stacking, level sensitive chasing and up to 512 memory scene capability. The encoder wheel and LCD readout make onboard editing quick and easy.

Specifications: 24/48 individual control channels ■ 384 programmable memory scenes ■ 24 user programmable level sensitive chase effects ■ 2-Scene Preset or Single Scene Operation (wide mode) ■ Dual Split Dipless Manual Crossfaders ■ Soft patching ■ Auto Faders ■ Program and Modify Memory in Live or Blind Mode ■ Fully Protected Non-Volatile EEPROM Memory ■ Audio Sync to Chase Effects Mode ■ Cue Stacking ■ Universal Internal Power Supply ■ NSI 128 Channel Micro-Plex to NSI Dimmers (3-pin XLR) ■ DMX512 Digital Control (5-pin XLR) ■ MIDI In/Out/Through ■ Optional 37 pin 0-10 V ■ Analog Control Port ■ Power: 120v/240v AC ■ Current Draw: 1Amp ■ Size: 29"x15"x4" ■ Weight: 6.82Kgs/15Lbs



MC 7008/16/24

CT-NSMC7008



Download Full line catalog of Leviton/NSI products at www.techni-lux.com

The MC 7000 series lighting consoles are simple and flexible with three operating modes. The consoles provide standard 2-scene preset, single scene (wide mode) for 16 channel capacity, and memory scene operation. The MC 7000 series is particularly well-suited to small theaters, stage performances and rental inventories. These products are so easy to program and operate, the instructions are printed right on the consoles.

Specifications: 8 Individual Control Channels ■ Configurable to 16 Channels ■ 8 Memory Scenes ■ 2-Scene Preset or Single Scene Operation (wide mode) ■ Dual Split Dipless Crossfaders ■ Individual Channel Bump Buttons ■ User Programmable Memory Scenes ■ User Programmable Chase Functions ■ Chase Rate Control (tap button) ■ Grand Master ■ Blackout Function ■ NSI Micro-Plex Control Signal (3-pin XLR) ■ DMX512 Digital Control (5-pin XLR) Outputs ■ Power: 15v DC ■ Current Draw: 200 mAmps ■ Size: 2.75"x10.625"x9" ■ Weight: 1.48Kgs/3.25Lbs



CT-NSMC7016 Specifications: 16 channels ■ 16 scenes ■ Size: 2.75"x16.63"x9" ■ Weight: 2.3Kgs/5Lbs

CT-NSMC7024 Specifications: 24 channels ■ 24 scenes ■ Size: 2.75"x22.63"x9" ■ Weight: 3.07Kgs/6.75Lbs

MLC 128R

CT-NSMLC128R



Take creative command of your intelligent lighting presentation with the fully programmable, rack mount MLC 128R control system from Leviton. With the pre-established library of lighting fixtures, you can simply and quickly control up to 128 intelligent devices. Show design is a snap with the ingeniously organized front panel that addresses your need for programming flexibility. And the unit provides as many as 1,024 user-programmable scenes to handle any lighting challenge.

Specifications: Up to 128 individual devices ■ 512 DMX control channels ■ 128 Micro-Plex control channels ■ Up to 1,024 scenes ■ 256 patterns (series of scenes) ■ Stores 256 shows (series of linked patterns) containing up to 24 patterns ■ Simultaneous control of up to 64 devices ■ Two line, 40 character backlit LCD display ■ Fade times from .1 second to 59 minutes, 59.9 seconds ■ MIDI In/Out/Through n Audio In ■ On-board joystick ■ Ports: MIDI In/Out/Through (5 pin DIN), DMX 512 (3 pin XLR), Micro-Plex (3 pin XLR), RS232 (DB9), Audio In (RCA jack) ■ Power: 12-15V DC ■ Current Draw: 800 mAmps ■ Size: 18.9"x 6.95"x 2.25", 19" 4U rack mountable ■ Weight: 8.1Kgs/17.9Lbs

DMX TOUCH PANEL

CT-TX1201



Specifications: Controls 12 channels directly ■ Dual signal output: DMX512 and 12 channels of 0-10vDC analog ■ One touch pad per channel ■ Auto Chasing: 3 zones of 4 channels each ■ Chase speed or audio advance ■ 12 scene memories of 12 steps each ■ DMX output on 5-pin XLR ■ Analog output via 15-pin D-sub connector ■ 19" rack mountable (2U) ■ Power input: 12-16vDC 1A ■ Size: 19"x3.46"x2.75" ■ Weight: 1.8Kgs/4Lbs

FOOT SCENE CHASER CONTROL

CT-F402



Specifications: 4 On/Off foot switches ■ Blackout ■ Master and channel level controls ■ 4 scene selection ■ Chaser: 4 programs ■ Variable chase by speed control or audio trigger ■ Outputs 0/10v ■ Size: 16.7"x7.9"x2.76" ■ Weight: 2Kgs/4.4Lbs

TOUCH PANEL

CT-T1202



Specifications: 12 Channel outputs on DINs and DB connector ■ 24 Touch Sensors: "Hold" and "Flash" ■ 3 chasing control sets: 1-4, 5-8, 9-12 ■ Dual color led display ■ Output 0-10V DC ■ Variable speed chase ■ Power: From pack or external DC ■ Size: 19"x3.5"x2.4" ■ Weight: 1.36Kgs/3Lbs

DMX MASTER II

CT-DMXMASTER2



Specifications: 240 output channels ■ 12 dedicated projectors ■ Maximum of 20 channels per projector ■ 30 banks of 8 scenes ■ 240 preset scenes ■ 6 preset sequences ■ Fade time function ■ 2 Jog wheels for pan/tilt control ■ Black-out function ■ Preset musical tempo using speed or Tap Sync ■ Individual access to all parameters on each light ■ Quick access to all scenes, sequences and macros ■ Illuminated 2 Line LCD screen display of all functions ■ Internal memory backup ■ Music detection: Audio jack sound activation or microphone for sound level control ■ Scene and sequence start with MIDI function ■ DMX output on 3-pin XLR ■ Steel body and metal front panel ■ Power supply wall transformer (DC9v-12v, 220mA) ■ Size: 18.9"x5.25"x3.25" ■ Weight: 2.5Kgs/ 5.5Lbs

COMMANDER 48

48 channel light-desk



CT-COMMAND48

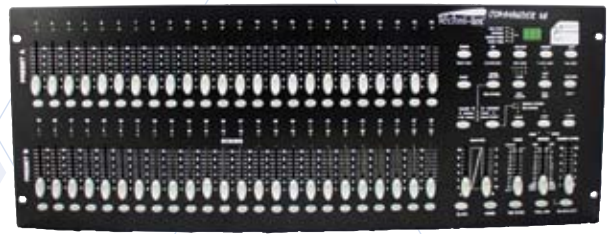

Specifications: 2 presets of 24 channels or 1 preset for 48 channels ■ Flash on each circuit ■ 4600 memories, 48 preset sequences ■ Fade/crossfade without dipping ■ Real-time or delayed scene programming ■ Sequence speed and editing time control ■ Internal memory backup ■ Multi-sequence mixing PCB ■ Music detection: audio jack sound activation and microphone for sound level control ■ Manual sequence start via Tap sync ■ Scene and sequence start with MIDI function ■ DMX 512 output channels with 3-pin XLR ■ Power supply wall transformer (DC9v-12v, 500mA) ■ Steel body and metal front panel ■ Size: 27.95"x10.47"x3.75" ■ Weight: 6.2Kgs/13.67Lbs

COMMANDER 24

24 channel light-desk



CT-COMMAND24



Specifications: 2 presets of 12 channels or 1 preset for 24 channels ■ Flash on each circuit ■ 4600 memories, 48 preset sequences ■ Fade/crossfade without dipping ■ Real-time or delayed scene programming ■ Sequence speed and editing time control ■ Internal memory backup ■ Multi-sequence mixing PCB ■ Music detection: audio jack or microphone for sound level control ■ Manual sequence start via Tap sync ■ Scene and sequence start with MIDI function ■ DMX 512 output channel with 3-pin XLR ■ Steel body and metal front panel ■ Power supply wall transformer (DC9v-12v, 500mA) ■ Size: 18.9"x10.43"x3.54" ■ Weight: 4.6Kgs/10.14Lbs

MOBILE 16

CT-MOBILE16



Specifications: Controls 16 channels of DMX512 ■ Patchable output channels ■ A/B master fader ■ Store 30 programs with 99 steps each ■ 16 flash or latch bump buttons ■ 16 programmable scenes ■ Programmable chases ■ Fade time, tap sync, and speed control ■ 8 sliders for channel adjusting ■ 4 digit LED Display ■ Black-out standby key ■ DMX 512 output 3 Pin XLR with polarity switch ■ Audio input via RCA, 100mV-1vpp ■ Audio sync with tap tempo ■ Audio level control ■ Midi In & Thru for additional triggering - 5 Pin Din ■ DMX512 polarity output switch ■ DB9 Female connector for an external control trigger ■ Power: 120v AC Adaptor Included - DC12V 500mA ■ Size: 12.6"x7"x2.6" ■ Weight: 2.3Kgs/5.07Lbs

OPERATOR

CT-OPERATOR



Specifications: Controls 192 channels ■ Use with up to 12 fixtures of 16 channels ■ 30 banks of 8 scenes for a total of 240 memories ■ Programmable chases ■ 8 sliders for channel adjusting ■ 4 digit LED Display ■ Black-out key ■ Speed and fade time sliders ■ DMX 512 output 3 Pin XLR with polarity switch ■ Audio input via built in microphone ■ Audio sync with tap tempo ■ Midi In for additional triggering ■ Size: 19"x5.25"x2.95" ■ Weight: 3.2Kgs/7Lbs

Specifications are subject to change without notice.

CT-CX SERIES

The CX series lighting boards are simple and flexible making them suitable for small theaters, musician stage performances and rental inventory. These provide the easiest way to control several dimming channels using DMX.

Specifications for all models: Individual channel level control ■ Scene memory ■ Master level control ■ Bump/Flash button per channel ■ Chase with audio input or manual speed/rate setting ■ DMX512 output via both 3 and 5 pin XLR connectors ■ Audio input via 1/4" jack ■ Blank/pause function ■ Power input: 12vDC, 1 amp

Lite-Puter

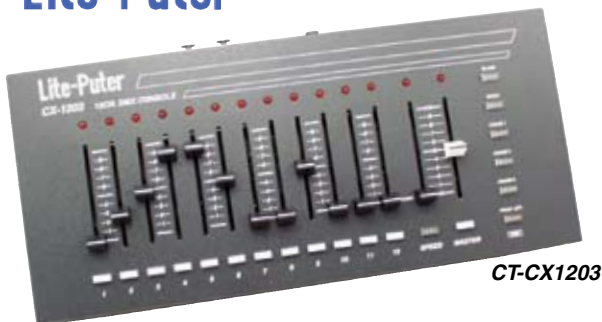

CT-CX1203



CT-CX803



CT-CX603



CT-CX403

- CT-CX403** 4 Channels, 4 scene memories
■ Size: 7.87"x6.7"x2.2" ■ Weight: 1.1Kgs/2.42Lbs
- CT-CX603** 6 Channels, 6 scene memories
■ Size: 7.87"x6.7"x2.2" ■ Weight: 1.1Kgs/2.42Lbs
- CT-CX803** 8 Channels, 8 scene memories
■ Size: 9.33"x6.7"x2.2" ■ Weight: 1.2Kgs/2.65Lbs
- CT-CX1203** 12 Channels, 12 scene memories
■ Size: 15"x6.7"x2.2" ■ Weight: 1.5Kgs/3.3Lbs

Lite-Puter

DIMMING CONSOLE CT-CX12



Specifications: 96 control channels on 24 faders with 4 page patch ■ 96 scenes and 24 chaser programs ■ 64 step capacity per program ■ LCD Display ■ Two sub-masters cross-fading and master level ■ DMX 512 output patchable & first 24 channel in analog 0/10vDC ■ Variable speed chase and audio input ■ Gooseneck light included ■ Size: 19"x14"x4.9" ■ 8 Rack spaces

ECP CONTROL PANEL SERIES



CT-ECP103J

The ECP control is ideal where you need a small, compact and simple to use DMX controller, tabletop or wallmount. The wall mount version is compact enough to be mounted into a recessed box on the wall. Both are perfect for store windows, display cases, restaurants, nightclubs and many color changing LED applications. You can very easily build programs, store them and recall them by simply pressing one of the 6 quick access buttons on the panel. High quality tactile switches are used for positive contact response to user while programming. For security and to help reduce

tampering by inexperienced users, a lock and unlock feature has been built in.

Specifications: Outputs the first 60 channels of standard DMX-512 / RS-485 signal ■ 4 different crossfade modes ■ Store/edit 40 programmable scenes ■ 6 programmable chases of 24 scenes ■ Variable chaser speed ■ Timer functions using clock ■ LCD Display ■ Indicator LEDs ■ Keypad lock & unlock ■ DC Power Input 12V DC 1A

CT-ECP103J Specifications: Table top version console ■ Signal output on both Female XLR 3 and 5 pin ■ Includes wall power supply ■ Size: 4.92"x 7"x 2.17" ■ Weight: 0.8Kgs/1.76Lbs

CT-ECP103JW Specifications: Wall mount version ■ Signal connection via phone jack 6P4C jack connector ■ Size: 4.6"x4.72"x 1.77" ■ Weight: 0.3Kgs/0.66Lbs



CT-ECP103JW

ECP-T04 DMX TOUCH SCREEN PANEL

CT-ECPT04

Features: With programming software, user can configure buttons, label, bar, clock, value and picture by the software. Download the screen configuration to **CT-ECPT04** by USB/LAN.



Built-in function:

- Clock
- Backlight setting
(3 options: normal, turn off in 5 minutes and turn off in 20 minutes.)
- Timer
- Password protection
- Accept IR remote controller control

Specifications: Power supply DC 12V ■ Signal input RS-485 (EDX) ■ Signal output DMX-512/1990 ■ DMX/EDX 4 PIN terminal block ■ Connection port USB/LAN ■ RAM memory 256MB ■ Touch Screen size 5.7 inch ■ Resolution 320 x 240 pixel ■ Color 262K colors ■ Size 8.5"x5.5"x 1.5" ■ Weight .52Kgs/1.15Lbs

System Diagram

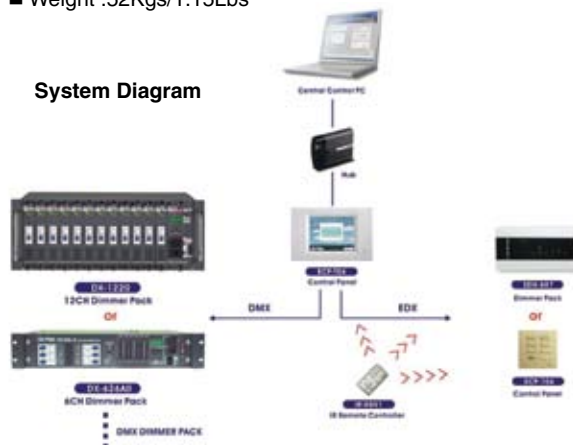

DIMMER/CHASER PD-PACK1



Exceptional value is what you get with the PD-PACK1 dimmer pack. Set the starting address using the LED display, connect the DMX line and off you go! Great for small bands and mobile disc jockey systems running 300, 500, 1000 watt par-cans. Also has 16 built-in chase programs for stand alone operation.

Specifications: DMX 512 addressable ■ 4 Individual Dimmer Channels ■ 8.3 Amps per channel ■ Maximum total load 20 Amps ■ Independent 10 Amp fuses per channel ■ 16 built in chase programs ■ Functions: Manual dimmer, manual program, auto program ■ For resistive or inductive loads ■ Multiple pack linking in/out ■ Input/output via 3-pin XLR ■ Digital LED display ■ 4 dual Edison receptacle outlets ■ 2 inch bar mounting ■ 3/8" clamp mounting holes ■ 4 Physical channels ■ 1, 2 or 4 Logical channels ■ 1000w max per channel ■ Size: 10.25"x7.5"x3" ■ Weight: 2.6Kgs/5.75Lbs



NSI DIMMER PACK PD-NSND4600

Specifications: 4 channel dimmer pack ■ 4 double Edison outlets at 600w maximum ■ NSI Micro-Plex 3 pin XLR control input ■ Pack start address selectable ■ LEDs for channel level indication ■ Internal fuse protection ■ 160 micro-second choke filters to reduce audio interference ■ Power: 120vAC 50/60Hz ■ 20 amp max capacity ■ Size: 8"x9.5"x3.5" ■ Weight: 3.41Kgs/7.5Lbs

DIMMER PACK PD-DX1

Single channel DMX dimmer or switch with digital address display. Dual Edison output. Truss or wall mountable.



Specifications: Selectable start address ■ Dimmer preset level ■ Dimmer limit setting ■ Switch or Dimming mode ■ DMX in/out using 3 pin XLR ■ Power: 120vAC 50/60Hz ■ Current draw: 6 Amps ■ Size: 3.5"x7.5"x3" ■ Weight: 1.1Kgs/2.5Lbs



4 CHANNEL AUDIO CHASER PD-A407

Specifications: 8 Amps x 4 Channels Inductive Load, total 15A maximum draw ■ Full Wave Zero-Crossing Circuit ■ Speed: Sound to Light or Manual ■ 16 pattern selection ■ LED output indicators ■ Full on bump button ■ Single edison outputs ■ Power: 120vAC 50/60Hz ■ Size: 8.95"x3.5"x3" ■ Weight: 1.36Kgs/ 3Lbs



4 CHANNEL DIMMABLE CHASER PD-A408

Specifications: 10 Amps x 4 Channels Inductive Load ■ Dimming fader provided (Total 15 Amps Max) ■ Sudden Current Protection ■ Chaser: 16 Patterns Selectable via 4 switches ■ Speed: Built in Mic. Sound to Light or Manual ■ 4 manual flash buttons & Full On button Override ■ Audio sensitivity adjustment 4CH. Audio Chaser ■ Power: 120vAC ■ Size: 9.45"x3.47"x2.92" ■ Weight: 1.36Kgs/ 3Lbs



DIMMER HALF RACK PD-DX404

Specifications: 5 amp x 4 channel single edison outputs ■ Maximum 5 amps per channel with a 15 amp total draw ■ DMX512 using 3 pin XLR ■ Advanced C3 dimming curve ■ LED display for DMX addressing, settings and channel output status ■ Channel bump test buttons ■ Lamp warm up feature ■ Power: 100-120vAC 50/60Hz ■ Size: 8.95"x3.5"x4.72" ■ Weight: 1.2Kgs/ 2.7Lbs

DMX DIMMER RACK PD-DX1220TB

Specifications: 12 channel modular dimmer pack, 2400 watts each ■ Hot swappable pull-out modules ■ Selectable dimming or switching per channel ■ DMX512 input/output on 5-Pin XLR isolated ■ DMX start address selectable ■ LED display for function status, voltage and temperature readings ■ Buttons for test and function selections ■ Built in test chase program ■ Internal 6 scene memory and adjustable fade time ■ Dimming level test and warm-up selectable for each channel ■ Channel output limiting ■ Square or linear dimming curve selectable ■ 12 resettable circuit breaker module with noise filters ■ Rear terminal connection panel ■ Analog 0/10v inputs & termination switch ■ Temperature controlled ventilation fan ■ Power: any from 90-240vAC 45-63Hz Single or 3 Phase ■ Size: 19"x6.93"x10.25" ■ Weight: 19.5Kgs/43Lbs



POWER SYSTEM WITH FLASH BUTTONS PD-PC3



The PC3 Power System with flash buttons is a complete low voltage switch system for professional mobile or club use. The system includes an 8 channel low voltage on/off and flash button controller (**PD-PC3M**) with 8 individual switches and a master on/off switch, an 8 remote channel power pack (**PD-PC3PACK**) and a 25 foot (**PD-PC3EXT**) connection cable. You can add another power pack so that one controller runs up to two remote power packs.

Specifications: 15 Amps circuit breaker ■ Built in transformer ■ (PD-PC3M) size: 19"x24"x 3.3" ■ Weight: 2Kg/ 4.4Lbs ■ (PD-PC3Pack) Size: 15.7"x3.5"x1.7" ■ Weight: 1.4Kgs/3.08Lbs ■ (PD-PC3EXT) 25ft ■ Weight: .45Kgs/1Lbs



4 CHANNEL RACK AUDIO CHASER PD-A410

Specifications: 10 Amps x 4 Channels Inductive Load ■ Total 15 Amps Max ■ Individually fused outputs ■ Full Wave Zero-Crossing Circuit ■ Chaser: 16 Patterns Selectable ■ Speed: Sound to Light or Manual 4CH. 16 Pattern Chaser ■ 1 rack space ■ Power: 120vAC ■ Size: 19"x1.75"x4.5" ■ Weight: 1.81Kgs/ 4Lbs



A/C POWER CENTER PD-PC1

A/C power center features 8 lighted switches, a 15 Amp resettable circuit breaker on the front and 8-120 volt plug sockets on the rear. Standard 19" 1U rack mount with 4 foot power cord. Features an additional un-switched outlet on the front.

Specifications: Size: 19"x3"x1.75" ■ Weight: 1.59Kgs/3.5Lbs

Lite-Puter



PD-DX1220TBDM
Quick change dimmer module.

Specifications are subject to change without notice.

Specifications are subject to change without notice.

TOPAZ SERIES

High density dimming and small footprint packages for versatile, powerful, yet cost-effective performance. From theatrical to architectural environments, these compact and rugged designed dimming cabinets are ideal for permanent installation in a wide array of facilities. Available in wall pack 12 or rack 24.

TOPAZ CONTROL MODULE

PD-NSTZCM

One control module is required per Topaz rack.



TOPAZ DIMMERMODULE

PD-NSTZDM24K

Dimmer modules available in 120 volt dual 1.8kw and 2.4kw capacities. Order filler modules when leaving any slot empty.



TOPAZ 12 WALL PACK

PD-NSTZ12W

Topaz 12 wall pack houses six plug-in dimmer modules. Size: 14.5"x14.25"x19" Weight: 18.1Kgs/40Lbs



TOPAZ 24

PD-NSTZ24R

Topaz 24 rack houses twelve plug-in dimmer modules. Size: 14"x21.5"x9" Weight: 25.9Kgs/57Lbs



Specifications: Plug-in Dimmer Modules ■ Plug-in Electronic Control Module ■ Lightweight ■ Single or Three Phase Power n No Disassembly or Reassembly in Installation ■ Multiple Racks may be Bussed Together (Pre-assembled at the Factory) ■ Locking Door Prevents Unauthorized Access ■ Multiple Voltages ■ Low Noise Fans ■ Terminals Provided and Labeled for All Control Circuits ■ Rating: UL & CSA Listed

D4DMX

PD-NSN4D20-3 DMX 512 using 3-Pin XLR version

PD-NSN4D20-5 DMX 512 using 5-Pin XLR version

Specifications: 1200 watts per channel dimmer ■ DMX and 3-pin Microplex ■ 2400 watt maximum ■ 120vAC ■ dual Edison outputs ■ Individual 10a reset breakers ■ Chaser function ■ Rating: UL listed ■ Size: 10.5"x2.625"x7.625" ■ Weight: 3.86Kgs/8.5Lbs

ARCHITECTURAL WALL DIMMER PACK

PD-NS2408CD

Specifications: 8 Individual dimmer or relay switch channels ■ 2,400 Watts per channel - 19,200 watts maximum ■ Dual SCR circuit design ■ Toroidal filtering reduces audio interference ■ 400 microsecond rise time ■ Microprocessor controlled ■ 8 Fully magnetic circuit breakers ■ 512 Channel address capable ■ Operates on LumaNet, Micro-Plex, DMX512 or 0-10v input ■ Screw terminal wire block inputs/outputs ■ UL Listed ■ Power: 120/240vAC operation ■ Size: 16.75"x20.25"x5" ■ Weight: 28.12Kgs/62Lbs



SATELLITE DIMMER PACKS

PD-NSDDSSXXX

The DDS series provides NSI/Leviton Micro-Plex system connect technology along with 0-10VDC analog control capability. DMX512 is an available option. All packs can be set to dim or switch mode and are U.L. listed.

Series Specifications: 4 channels ■ Dual SCR design ■ Selectable start address dip switches ■ External fusing ■ Toroidal filtering to reduce audio interference ■ User selectable switch or dim mode ■ Soft start operation ■ External circuit breaker ■ Power ON LED indicator ■ Internal sequence and rate adjustment ■ Control status LED ■ Individual channel LED indicator ■ NSI 3-pin XLR micro-plex in/out ■ Power: 120vAC 50/60hz



PD-NSDDSS5600: 600 watts per channel ■ single Edison output ■ 160 microsecond rise ■ internal hanging bracket ■ Size: 8.25"x9.8"x2.6" ■ Weight: 3.18Kgs/7Lbs

PD-NSDDSS6000: 1200 watts per channel ■ 2400 watt maximum ■ dual Edison outputs ■ 400 microsecond rise ■ external mounting flange ■ Size: 10.9"x9.5"x3.75" ■ Weight: 5Kgs/11Lbs

PD-NSDDSS6000+: 1200 watts per channel ■ 4800 watt maximum using two power cords ■ dual Edison outputs ■ 400 microsecond rise ■ external mounting flange ■ Size: 10.9"x9.5"x3.75" ■ Weight: 5.45Kgs/12Lbs



DMX KIT

PD-NSOPT5512

DMX option kit to convert any DDS pack from Micro-plex to DMX512



DX-401A DMX DIMMER RACK

PD-DX401A

Specifications: 4 Channel Dimmer, 1200 watts per channel ■ Dual Edison plug output per channel ■ Total pack power output 3600 watts/30 amps ■ Two 120vAC power cord inputs ■ DMX input/output using 3 pin XLR ■ Resettable 10A circuit breakers per channel ■ Automatic warm up function to protect loads ■ Manual bump buttons ■ Selectable to dim or switch channels ■ Auto frequency tracking ■ Channel dimmer test and monitor channel value on display ■ LED digital display ■ DMX start address setting ■ Advanced C3 linear dimming curve ■ Includes truss mount plate for clamp attachment ■ Size: 8.7"x10.24"x2.75" ■ Weight: 3Kgs/6.62Lbs



DX-402A DMX DIMMER RACK

PD-DX402A

Specifications: 4 Channel Dimmer, 1200 watts per channel ■ Dual Edison plug output per channel ■ Total pack power output 3600 watts / 30 amps ■ Two 120vAC power cord inputs ■ DMX input/output using 3 pin XLR ■ Resettable 10A circuit breakers per channel ■ Automatic warm up function to protect loads ■ Variable level sliders for manual setting ■ Selectable to dim or switch channels ■ Auto frequency tracking ■ Channel dimmer test and monitor channel value on display ■ LED digital display ■ DMX start address setting ■ Advanced C3 linear dimming curve ■ Includes truss mount plate for clamp attachment ■ Size: 8.7"x10.24"x2.75" ■ Weight: 3Kgs/6.62Lbs



Back of PD-DX402A

Lite-Puter



Back of PD-DX626

DX-626 DMX DIMMER RACK

PD-DX626

Specifications: 6 channel dimmer pack, 2400 watts each ■ Slider controls on unit for manual setting ■ Selectable dimming or switching ■ DMX512 input on 5-Pin XLR isolated ■ DMX start address selectable ■ LED display for function status and test buttons ■ Built in test chase program ■ Dimming level test and warm-up selectable for each channel ■ Square (C2) or Linear (C3) dimming curve selectable ■ 6 resettable circuit breakers ■ Rear panel with dual Edison NEMA 5-15 plug outputs ■ Terminal block power input ■ Power: any from 90-240vAC 45-63Hz Single or 3 Phase ■ Size: 19"x3.5"x11.81" ■ Weight: 8Kgs/17.6Lbs

PRO-DIMMERS PD-PACKPRO6



The Pro-Dimmer6 is a versatile 6-channel DMX-512 dimmer and switch pack which provides dimmer curve selection for each channel-square, switch, or linear. Each channel can be set as either a dimmer or relay and set to any DMX address. This Pro-Dimmer6 also gives you an individual switch, circuit breaker, and plug per line.

Features

- 6-channel DMX-512 dimmer /switch pack
- Each channel can be set to any DMX address
- Variable electronic dimmer (0-100%)
- Each ch. can be set as either dimmer or relay
- Dimmer curve selection for each channel: square, switch or linear
- Dual 20A power lines(requires 2 separate circuits)
- Individual switch, circuit breaker and plug per line
- 2 plugs per channel
- 5 pin XLR in/out
- 1/2" clamp mounting holes

Specifications: Input voltage equals output voltage ■ Output: 10A per ch., 20A per line, 40A max ■ AC power: 110 - 120VAC 50/60Hz ■ Size: 19.5"x5.78"x4" ■ Weight: 4.5Kgs/10lbs



Mounting bracket of PD-PACKPRO6.

Wall Panels

Luma Net Architectural Control Stations

Luma-Net architectural control stations are some of the most reliable, easy-to-use wall mount controls available. They are ideal wherever cost, durability, and ease of use are major considerations and provide total lighting integration, combining house and stage lighting into one cohesive system. Five different models provide zone and scene control, as well as individual channel faders. Mount in standard wall gang electrical boxes.

Specifications: Control up to 100 dimmer channels ■ External lockout function ■ Programmable with Luma-Net PC Software and Interface I/F 501 or from front panel ■ Programmable fade times

400 SERIES - Remote Memory Control Panels with push button controls ■ Programmable Master/Slave Operation

CT-NS400CP Raise & lower control over 4 zones by holding a button

CT-NS404CP 4 Scene control with one button press

CT-NS408CP 8 Scene control with one button press

■ Size: 4.5"x4.5"x2.75" (2 gang deep box) ■ Weight: .45Kgs/1Lbs



PROTOCOL CONVERTER AC-NSOPT501

The OPT501 is a very flexible protocol interface device can be ordered with a host of different in/out combinations of the following protocols: DMX512, CMX, AMX, MicroPlex, Luma-Net, MIDI, RS232, and 0-10v analog. In addition to merging lighting protocols, this interface device is capable of converting computer protocols to lighting protocols.

ing protocols: DMX512, CMX, AMX, MicroPlex, Luma-Net, MIDI, RS232, and 0-10v analog. In addition to merging lighting protocols, this interface device is capable of converting computer protocols to lighting protocols.

CONVERTER

AC-DP3-72

Converts DMX512 to 0/10v outputs. 72 analog output channels. Allows selection of start address. Rack mount unit. **Specifications:** Power: 120vAC ■ Size: 19"x1.75"x9.5" ■ Weight: 3.6Kgs/8Lbs

TOURING DIMMER RACK



Modular rack systems can be custom built to fit any application providing the flexibility and serviceability demanded of a Touring Dimmer Rack. Quiet, continuous operation makes them ideally suited for corporate industrials, theatre, and live performance. Touring Dimmer Rack comes with the following features:

- Simultaneous digital DMX-512 and Optional Analog Input
- System Status Indicators
- 100% Duty Cycle
- Easy Access Hot Patch Bay
- Fully Modular Power and Control Electronics

PD-LEPTR48

This is one popular example. Many other configurations available, please request more information.

Specifications: Rack Style: Rack, 48 Steel ■ Enclosure: Rack, dimmer case, Steel, 23RU with Heavy Duty Colson Castors ■ Power In: Rack, Power In Panel, ADI Dual Cam-Loc, Rev NG ■ Mains Breaker: Rack, Mains Panel, 400 amp 1-3 Phase ■ Load Patch: Panel, Patch, Flat, 48 Circuit, 5RU, With labels 1-48 ■ Auxiliary: Rack, distro panel, 2 ea 1 pole 20 amp breakers and 2 ea duplex outlets ■ Control Input: DMX Control In, 2RU - Neutrik Connectors ■ Additional Breaker Rack Panel, 6 ea 1-pole 20 amp, wired for patch bay ■ Load Connectors: Rack, Load Panel, 16 Socapex, 8RU ■ Option 1: Panel, Meter, Voltage, XYZ ■ Additional Patch: Panel, Patch, 6 Circuit, non-dim ■ Additional Load: Rack, Load Panel, 6 ea stage pin and 3 ea duplex ■ Dimmer Qty: 4 ■ 48 Channel Steel Rack ■ Size: 47.5"x21.25"x29.75"



Specifications are subject to change without notice.



CT-NS808CP



CT-NS408CP

800 SERIES - Remote Memory Control Panels with manual slide controls ■ Programmable Preset Buttons ■ All Off Button ■ Programmable On and Off scenes

CT-NS804CP 4 Channel slider station with On/Off programmable scenes ■ Size: 4.5"x4.5"x2.75" (2 gang deep box) ■ Weight: .45Kgs/1Lbs

CT-NS808CP 8 Channel slider station with On/Off programmable scenes ■ Size: 4.5"x6.4"x2.75" (3 gang deep box) ■ Weight: .9Kgs/2Lbs

Specifications: 512 control channel addresses ■ configure mode select switches ■ 4 line analog (0-10Vdc) or dry contact closure input port ■ DMX512 in/out ports in 5 pin XLR ■ NSI Microplex In/Out ports in 3 pin XLR ■ RS-232 input port via DB9 connector ■ NSI Luma-Net RJ-14 connector ■ 8 pre-programmed auto sequence chases ■ programmable precision auto-cue playback, and real-time ASCII control over dimmers via RS-232 ■ Power: 15vDC external power supply ■ Size: 6.9"x4.5"x2.5" ■ Weight: 3.3Kgs/7.1Lbs



DMX ANALYZER AC-DMXTESTA

This DMX ANALYZER is the complete DMX testing tool, making it essential to any technician working with DMX systems. It incorporates numerous functions and features in very attractive, compact and ergonomic design. Its intuitive menu and quick shuttle button operation also make it very easy to understand. The DMX Analyzer helps technicians quickly find the source of any DMX problem, whether it's fixture, data or cable related.

Specifications: DMX analyzer and tester ■ Case molded in high impact ABS ■ Digital/analog cable tester ■ Editable intelligent light library from 10 to 36 DMX channels per fixture and 29 effect functions ■ Adjustable contrast Backlight LCD display of 4 x 16 characters ■ Test up to 10 fixtures with select DMX start addresses ■ "SHUTTLE" wheel browse to scroll through menus ■ Test for format data, delay and level of data ■ 512 individual DMX channels ■ Displaying DMX data in different value formats (decimal, hexadecimal or percentage), bar charts and max/min ■ Received data can be stored and sent ■ Up to 15 memories can be recorded and played back ■ Start TX code maintained RX displaying/normal, selectable DMX polarity ■ Selectable interface language: English, French, German and Spanish ■ Power supply: DC 9V, 500 mA (rechargeable battery included) ■ DMX Connectors: both 3 pin and 5 pin XLR ■ Case Included ■ Size: 7.9"x6.3"x2.2" ■ Weight: 1.2Kgs/2.64Lbs



MICROTECH DMX TEST TOOL AC-DMXTEST113 (3 Pin XLR) AC-DMXTEST115 (5 Pin XLR)



This DMX tester is loaded with the features needed to solve tricky DMX problems that occur with digital dimmers, moving lights, color scrollers and virtually anything else that uses DMX. As lighting technology gets more "intelligent" so should your tools. The MicroTech is the

perfect combination of powerful yet simple to use functions in an ultra-miniature package for the ultimate convenience.

Specifications: Display and check dimmer levels, locate dimmers that are changing levels, record up to 15 scenes into snapshot memory, Check data link for errors ■ Show number of dimmers being sent by console ■ Calculate the console's update rate ■ Automatic hands-free console backup ■ Play back prerecorded scenes ■ Edit scenes live ■ Fade and/or bump dimmer levels up and down ■ Display levels in percent, decimal or hexadecimal ■ Large LED display ■ Available with 5 pin or 3 pin XLR in/out ■ Power: 2 x "AA" alkaline batteries or AC Adapter ■ Size: 3.97"x2.38"x1.5" ■ Weight: 0.22Kgs/0.5 Lbs



DMX SPLIT 4 AC-DMXSPLIT4

Perfect way to split and isolate DMX512 lines for protection and multiple data runs. Provides one input, one pass through and 4 isolated outputs in both 3 and 5 pin configurations.

Specifications: Power: 120vAC ■ Size: 13.2"x8.27"x3.35" ■ Weight: 2.9Kgs/6.3Lbs

DMX SPLIT 8 AC-DS5



The DataSplitter 8 is ideal for the distribution of digital signals from DC to 500KHz (such as DMX, PMX, RS232, RS423, RS422, RS485 etc). Signal In/Thru is provided in addition to the 8 independent outputs, all connections are 5pin XLR. Protection on ALL inputs and outputs capable of withstanding isolation from 240V. The unit is 1U rack mount 19" or may be truss mounted using two clamps with a 10mm thread bolt.

Specifications: Power: 12-25vDC or 100-240vAC 50/60hz ■ 1U Rack Mount 19" ■ 5 pin XLR input ■ 5 pin XLR thru output ■ 8 isolated outputs 5 pin XLR ■ On/Off power switch ■ Size: 19.1"x1.75"x4.33" ■ Weight: 1Kgs/2.2Lbs

WIRELESS W-DMX AC-WDMX-S1

Wireless DMX S-1 Blackbox Indoor Transmitter



AC-WDMX-R512

Wireless DMX R-512 Blackbox Indoor Receiver

The W-DMX system is a user-friendly and reliable way of transmitting and receiving DMX wirelessly. Multiple transmitters and receivers can be used in close proximity as they will not interfere with each other. The standard configuration uses 512 DMX channels, however systems can be set to support up to 16 universes or 8,192 DMX channels. The W-DMX system supports both Multi-Point and Point-To-Point operation. In a multipoint system, each DMX512 device has its own receiver, which negates the need for DMX512 cable as the entire system is wireless. In a Point-To-Point situation, W-DMX is used to 'bridge' a distance. It is easy to use with a lightweight compact size and interchangeable antennas.

The technology was invented by the US Military and is used in the GSM networks as well. It uses Adaptive Frequency Hopping Spread Spectrum (FHSS), which changes frequency 1000 times per second and uses only channels that are not used by other W-Lan and/or other products on 2.45Ghz band. Additionally, Time Division Multiple Access (TDMA) gives the user a guarantee for a much safer technology without interference.

Specifications: Transmission Range: with standard antenna 1km (.62 miles) ■ DMX512 using 5 pin XLR ■ Frequency Range: 2400-2483 MHz ■ One standard 2dBi antenna included ■ Approvals: CE, UL, FCC ■ Power: universal 90-250vAC ■ Current: 1 amp ■ Size: 7"x5"x1.75" ■ Weight: 0.77Kgs/1.7Lbs

DP-8I DMX SPLITTER PANEL AC-DP8I



DP-8I Eight way DMX splitter/repeater is ideal for the distribution of DMX signals. Provides one male XLR 5 pin for DMX input and 8 XLR 5 pin female DMX connectors for output. Protection on ALL inputs and outputs are photoisolated to keep signals separated. Helps protect controller from any noise coming back on a DMX line. Built in power supply unit. The unit occupies 1U rack mount space, 19" wide.

Specifications: Power: 100-240vAC 50/60Hz via rear IEC30220 connector ■ 1U Rack Mount 19" ■ 5 pin XLR male input ■ 8 isolated outputs 5 pin XLR females ■ On/Off power switch in front ■ Size: 19.1"x1.75"x4.5" ■ Weight: 1.16Kgs/2.6Lbs

OUTSTATIONS OSI CT-PLOS1



OS1 Outstation is a compact 12 Button, 60 Scene, 54 Channel DMX programmable control desk that is ideal as an architectural controller and as a remote for our ChromaZone. It is beautifully finished in stainless steel and fitted with chrome push buttons so it will fit into any decor. The OS1 is ideal for offices, bars, restaurants, foyers in fact anywhere an easy to use and program DMX controller is required. The OS1 automatically receives its 18-25VDC power from a Pulsar dimmer or ChromaZone.

Specifications: Size: 5.75"x5.75"x1.26" ■ Weight: 2.1Kgs/4.63Lbs

MUSIC STAND LAMP AC-MH1000

The ultimate in attractive design and simplicity. Features include glare-free, full-width, audience-shielded illumination. It has ample clearance of even the taller scores of music, and dual clips for assured attachment, yet easily installed and removed. Complete with 40-watt bulb, 8-foot cord, and switch. Durable black enamel finish. Rigorously inspected and tested, this lamp is ETL and CSA approved, and is designed for years of trouble-free service. This is the light fixture option only, does not include the music stand.

Specifications: Power: 117vAC ■ 8 foot power cord with plug ■ Size: 9"x6"x4" ■ Weight: 0.37Kgs/0.82Lbs ■ Color: Black



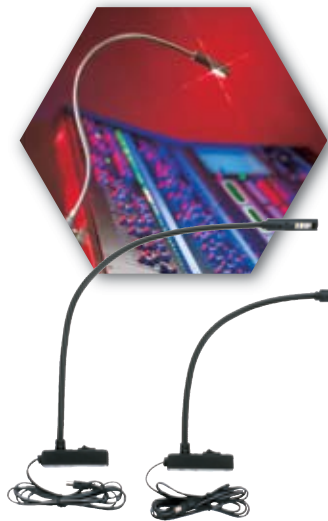

LED GOOSENECK LIGHTS

LED Technology brings new advantages to the Littlite. Long life, shock and vibration resistance along with cool operation make the Littlite LED the perfect choice for many applications.

- Excellent color rendering through the addition of red LEDs to the usual "white" LED light sources.
- Switchable red only output (Lampsets only). The Littlite LED can become a red light for unobtrusive use with no impact on the user's night vision.
- Low power - Approximately 100 milliamps at 12 volts drives the Littlite LED to full output.
- Efficient - Most of the power used by the Littlite LED is delivered to the LEDs, not a resistor.
- Long life - Over-driving seriously reduces the life of white LEDs. The LEDs in the Littlite LED are not overdriven and may be expected to remain useful for over 5000 hours of operation.
- Lifetime warranty on the mechanicals, two year warranty on the LED element.

LED - Attached Chassis & Switch

- GL-L12-LED** LED Gooseneck 12" - w/ switch & transformer
- GL-L18-LED** LED Gooseneck 18" - w/ switch & transformer

Individual Permanent Mount

- GL-12P-LED** LED 12" - Permanent Mount
- GL-18P-LED** LED 18" - Permanent Mount

Individual Detachable with BNC connector

- GL-12G-LED** LED 12" - BNC
- GL-18G-LED** LED 18" - BNC

Individual Detachable with XLR connector

- GL-12X-LED** LED 12" - XLR 3-Pin
- GL-18X-LED** LED 18" - XLR 3-Pin
- GL-12XR-LED** LED 12" - XLR 3-Pin Right Angle
- GL-18XR-LED** LED 18" - XLR 3-Pin Right Angle
- GL-12X4-LED** LED 12" - XLR 4-Pin
- GL-18X4-LED** LED 18" - XLR 4-Pin
- GL-12XR4-LED** LED 12" - XLR 4-Pin Right Angle
- GL-18XR4-LED** LED 18" - XLR 4-Pin Right Angle

Automotive

- GL-L9/12-LED** LED 12" Auto 12v

With BNC

- GL-6G-HI** High Intensity 6" - BNC
- GL-12G** Lo-Intensity 12" - BNC
- GL-12G-HI** High Intensity 12" - BNC
- GL-18G** Lo-Intensity 18" - BNC
- GL-18G-HI** High Intensity 18" - BNC

With XLR 3-Pin

- GL-6XH** High Intensity 6" - XLR 3-Pin
- GL-12X-HI** High Intensity 12" - XLR 3-Pin
- GL-12XR-HI** High Intensity 12" - XLR 3-Pin Right Angle
- GL-18X** Low Intensity 18" - XLR 3-Pin
- GL-18X-HI** High Intensity 18" - XLR 3-Pin
- GL-18XR-HI** High Intensity 18" - XLR 3-Pin Right Angle

With XLR 4-Pin

- GL-12X-HI4** High Intensity 12" - XLR 4-Pin
- GL-12XR-HI4** High Intensity 12" - XLR 4-Pin Right Angle
- GL-18X-HI4** High Intensity 18" - XLR 4-Pin
- GL-18XR-4** Lo-Intensity 18" - XLR 4-Pin Right Angle
- GL-18XR-HI4** High Intensity 18" - XLR 4-Pin Right Angle

With Permanent Mount

- GL-18P-HI** 18" High Permanent Mount



High quality flexible gooseneck lights and accessories by Littlite are the industry standard. All units come with lamp. High intensity refers to gooseneck with Q5 or quartz 5 watt lamp. Low intensity is 2.4 watt incandescent.

All below include a 120v transformer. To order without transformer for 12v use add an "A" to the code. For 240v add an "E" to our order code.

Limited Lifetime Warranty

Low Intensity - Attached Base

- GL-L2/12** Gooseneck 12" w/dimmer & transformer
- GL-L2/18** Gooseneck 18" w/dimmer & transformer

High Intensity - Attached Base

- GL-L3/6** Gooseneck 6" w/dimmer & transformer
- GL-L3/12** Gooseneck 12" w/dimmer & transformer
- GL-L3/12A** Gooseneck 12" Hi-dimmer no transformer
- GL-L3/12E** Gooseneck 12" Hi-dimmer & European 220v transformer
- GL-L3/18** Gooseneck 18" w/dimmer & transformer

High Intensity - Detachable BNC

- GL-L4/12** Gooseneck 12" w/dimmer & transformer
- GL-L4/18** Gooseneck 18" w/dimmer & transformer

High Intensity - Automotive Types

- GL-L9/18** Gooseneck 18" w/dimmer 12v

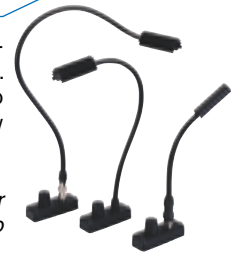

RAKLITE SERIES

When mounted at the top of your rack, the Raklite provides illumination for an entire rack of lighting or audio equipment. Its flexibility allows you to adjust illumination for patching or general rack service.

General Specifications: dimmer ■ Goosenecks are recessed into panel for transport ■ Power: 120 VAC 30 watts (transformer included) ■ .090 Aluminum (6061 Alloy) ■ Size: 19"x1.75"x1.677" ■ Color: Black

GL-RL10D Specifications: High Intensity double, permanently attached 12" goosenecks ■ Weight: 1.134Kgs/2.5Lbs ■ Color: Black

GL-RL10S Specifications: Power: High Intensity single permanently attached 12" gooseneck ■ Weight: 0.7541Kgs/1.66Lbs ■ Color: Black



The **GL-RL10D-LED** and **GL-RL10S-LED** are the same as **GL-RL10D** and **GL-RL10S** with the exception of 12" LED's in place of high intensity goosenecks, an on/off switch and energy efficient solid state power supply. The LED light will not toggle between red and white. ■ Color: Black



RAKIT MOUNTING BRACKET

GL-RAKIT

Mounting bracket to mount L-series lampsets to a rack rail. Rakit allows you to add a high quality rack light without occupying any rack spaces. Mounts on standard rack rail and piggybacks over the rack mounted gear. Easy to install. Simply mount the lampset to the Rakit, and then mount the assembly on the rack rail using the existing screws which are 3 rack units apart, top to bottom and run the power cord. Also can use RL-BA cord to tap into a 12 volt BNC rack power point. **Specifications:** 0.062 Aluminum ■ Size: 5.25"x1"x0.875" ■ Weight: 0.0312Kgs/0.0688Lbs ■ Color: Black



MS SERIES 18" Music Stand Light LED WITH TRANSFORMER

GL-MS18-LED

Unlike many other music stand lights, the Littlite Music Stand light can be mounted on the side of the stand putting the switch closer to the performer and eliminating a bulky, obtrusive top-mounted light. Mounts on any standard music stand with a flat edge. The gooseneck is flexible and allows for exact direction of lighting to be positioned as desired. Additionally, the LED version is cool to the touch. Includes new switching power supply. And using the WYE, PYE and EXT accessory cords, multiple lights can be powered by a single power supply.



Specifications: LED Light Source ■ 18" Flexible Gooseneck ■ Attached Lamp with chassis for music stand mounting to flat edge ■ 6ft Power Cord and Transformer ■ On/Off Switch ■ Low Voltage Operation ■ Base Size: 3"x1"x1.5" ■ Gooseneck base to hood Size: 20.25" ■ Hood Size: 2.5"x 0.5"x0.719" ■ Weight: 0.5982Kgs/0.5Lbs

For a complete listing of Littlite products Visit our Website at www.techni-lux.com

PYE POWER CONNECTOR

GL-PYE



Connect up to four Low Intensity or LED goosenecks to a single GXF-10 or EXF-10G power supply. Not recommended for use with High Intensity goosenecks. **Specifications:** 16 inches long, female 2.1mm to four males ■ Weight: 0.032Kgs/0.07 Lbs

BA BNC POWER CONNECTOR

GL-BA



Littlite Adaptor to power a lampset from a 12 volt BNC type lamp outlet. This is a great way to add a Littlite to a rack mount, BNC equipment mixer.

Specifications: 2 foot cable from BNC to 2.1mm male ■ Weight: 0.04Kgs/0.08Lbs

RWB ROUND WEIGHTED BASE

GL-WB



The RWB is designed to be integrate a standard Littlite lampset in the housing for a sleek, low-profile appearance. Littlite lampsets can also be mounted on top of the base. Weighted metal base that is screwed onto the bottom of the Littlite chassis. Converts "L" models into free standing lights. **Specifications:** Size: 0.75"x4" Diameter ■ Weight: 0.42Kgs/0.9Lbs ■ Color: Black

LITETOTE

GL-LITETOTE



Littlite Litetote is a heavy duty tote canvas pack to keep your Littlite goosenecks safe and secure while on the road between shows. Helps keep your accessories together also. Hook and loop material secures the flap and that spiffy Littlite logo identifies you as a discerning judge of gooseneck task lamps.

Specifications: Size:22.75"x7.25"x0.5" ■ Weight: 0.15Kgs/0.34Lbs

WYE CORD ADAPTER

GL-WYE



Littlite Y-cord adapter connects two Littlites to a single GXF10 power supply

Specifications: 6 inches long, female 2.1mm to two males ■ Weight: 0.02Kgs/0.04Lbs

GXF-10 POWER SUPPLY

GL-GFX10



Littlite electronic switching power supply transformer 120vAC to 12vAC at 1 amp, 2.1mm male output with 6 feet of cable - runs up to 4 low intensity or 2 high intensity units. Convenient disconnect for easier transport. Narrower design only takes up one power strip space. Smaller, lighter and more efficient than original WXF10 version.

Specifications: UL and CSA approved. ■ Size: 6" ■ Weight: 0.11Kgs/0.25 Lbs

GAD ADAPTER

GL-GAD



Littlite Adaptor cord connects new GXF10 power supply to older Littlite lampsets - 6 foot cable from spade ends to 2.1mm female ■ Weight: 0.032Kgs/0.07Lbs

EXT EXTENTION CABLE

GL-EXT



Littlite 6' extension cable for power supply - male to female 2.1mm plugs. May use extra extensions to go farther distances.

Specifications: 6 foot cable from male 2.1mm to female 2.1mm ■ Weight: 0.05Kgs/0.1Lbs



Mounting

- GL-CL** Adjustable clip for use with L models
- GL-HTC** High tension clamp
- GL-MB** Magnetic base
- GL-SM** Snap mount for L models
- GL-WB** Weighted base for L models
- GL-MP2** Dual mount plate for PS/DM/Permanent models
- GL-XLR-PS3** 3 Pin panel socket for "X" series
- GL-XLR-PS4** 4 Pin panel socket for "X" series
- GL-XLR-PS** Panel socket BNC connector for G series

Hoods

- GL-HH** High intensity hood
- GL-LH** Low intensity hood
- GL-LX** X series hood with O-rings

Lamps

- L64111-O** Quartz 5 watt lamp
- L1815-O** Incandescent 2.4 watt lamp

Parts

- GL-CF** Color filters for high hoods: Clear, Red & Blue set
- GL-NVF/BLUE** Night Vision Color Filters,3 blue
- GL-NVF/CLEAR** Night Vision Color Filters,3 clear
- GL-CP** Cigarette lighter 12v power plug
- GL-DM** Dimming rheostat with off position
- GL-LK** Dimmer knob
- GL-O-KIT** "O" Rings – 12 pack
- GL-O-KIT-X** "O" Rings X – 12 pack B
- GL-RD** Dimmer L replacement
- GL-WXF** Wall transformer 120vAC to 12vAC 500mA
- GL-WXF10** Wall transformer 120vAC to 12vAC for 4 high intensity 5w lamps

Specifications are subject to change without notice.

GUSTO FOG MACHINE SERIES

The advanced Gusto Fog Machine range features the latest in fog atmosphere producing technologies available today. All machines are thermally controlled to produce a safe, dry and consistent fog effect. To help prevent pump burnout, all Gusto units are fitted with a unique empty fluid tank sensor to prevent the dry running of pumps. However, the fluid containers are still removable for filling and cleaning purposes. The innovative and stylish shell design make maintenance most convenient and simple. This modular design allows quick access to the heater core, electronic circuit or pump easily when necessary. Standard with each machine is a remote and built-in DMX control. Gusto fog machines operate on professional water based fogging fluids.

FOG MACHINE GT1800 WITH REMOTE

FM-GT1800

Features:

- Rapid dual heater system design
- Digital remote control
- On-board DMX
- 50% Energy saving when on standby
- Reduced nozzle blockage by using single piece diecast aluminum heater core
- Variable fog output
- Empty tank sensor

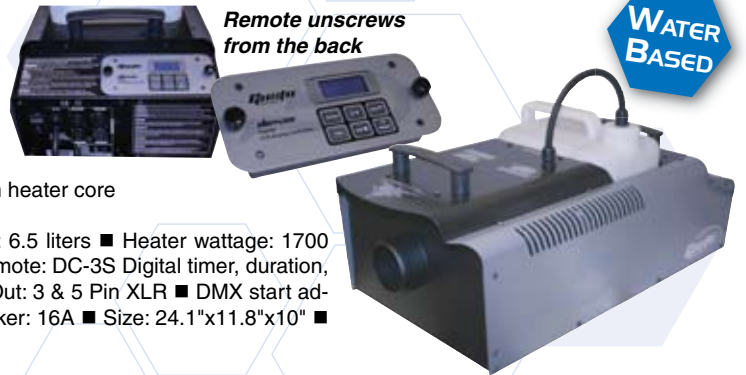

Specifications: Fog output: 30,000 cu/ft per minute ■ Tank capacity: 6.5 liters ■ Heater wattage: 1700 watts ■ Initial warm-up time: 5 minutes ■ Dual carrying handles ■ Remote: DC-3S Digital timer, duration, & variable volume output remote ■ DMX Channels: 1 or 3 ■ DMX In/Out: 3 & 5 Pin XLR ■ DMX start address on digital remote ■ Power: 120vAC 50/60Hz ■ Resettable Breaker: 16A ■ Size: 24.1"x11.8"x10" ■ Weight: 14Kgs/30.9Lbs ■ Color: Black & Silver

FOG MACHINE GT1250 WITH REMOTE

FM-GT1250

Features:

- Variable fog output
- Empty tank sensor
- Reduced nozzle blockage by using single piece diecast aluminum heater core
- Truss mountable with yoke
- On-board DMX



Specifications: Fog output: 20,000 cu/ft per minute ■ Tank capacity: 2 liters ■ Heater wattage: 1200 watts ■ Initial warm-up time: 7 minutes ■ Mounting yoke included ■ Carrying handle ■ Remote: TC-3 Timer interval, duration & variable volume output remote with 26' cable ■ DMX Channels: 1 or 3 ■ DMX In/Out: 3 Pin XLR ■ DMX start address using dip switch ■ Power: 120vAC 50/60Hz ■ Fused: 13A ■ Size: 16.2"x9.06"x7.95" ■ Weight: 7.5Kgs/16.5Lbs ■ Color: Black & Silver

FOG MACHINE GT1000 WITH REMOTE

FM-GT1000

Features:

- Compact truss mountable with yoke
- Empty tank sensor
- On-board DMX



Specifications: Fog output: 10,000 cu/ft per minute ■ Tank capacity: 2 liters ■ Heater wattage: 1000 watts ■ Initial warm-up time: 4.5 minutes ■ Mounting yoke included ■ Carrying handle ■ Remote: TC-1X Timer interval & duration remote with 26' cable ■ DMX Channels: 1 ■ DMX In/Out: 3 Pin XLR ■ DMX start address using dip switch ■ Power: 120vAC 50/60Hz ■ Fused: 12A ■ Size: 14.9"x9.06"x7.95" ■ Weight: 6Kgs/13.2Lbs ■ Color: Black & Silver

FOG MACHINE 700W WITH REMOTE

FM-11

This is our smallest and most affordable mobile fog machine. Its rounded profile is compact and lightweight. Features a bracket for hanging on truss, a remote switch with 10 ft. of cable and .8 liter internal fluid tank. Enhanced 3,300 cubic feet output per minute. Designed for small bands, DJ's and small venues.

Specifications: Power: 120vAC 50/60Hz ■ Current: 7 Amps ■ Size: 13"x6.29"x5.1" ■ Weight: 4Kgs/8.8Lbs ■ Warm up: 4 minutes



FOG MACHINE 1500W WITH LCD REMOTE

FM-10

FM-10 Professional fog machine can be used for large, mobile and permanent installations requiring an output of 20,000 cubic feet per minute. Contains a 6 Liter removable fluid container and two handles. The digital LCD remote control allows duration, interval and variable output adjustments. The FM-10 is also controllable with DMX512.

Specifications: Power: 120vAC 50/60Hz ■ Current: 14 Amps ■ Size: 24.4"x11.8"x8.27" ■ Weight: 15Kgs/33Lbs ■ Warm up: 12 minutes



HAZER Z80T WITH REMOTE

FM-HAZERZ80T

The Z80T is a haze generator that produces a translucent medium to maximize and enhance beams of light without creating clouds of smoke. It uses a water-based fluid which is safe, easy to use, and does not leave any residue or sticky deposits on surrounding surfaces and lighting equipment. Produces approximately 1500 cubic feet per minute. It is virtually silent and provides an even dispersal of haze. Included remote controls the manual or automatic ON/OFF operation and the variable interval timer setting.

Specifications: Haze output: 1,500 cu/ft per minute ■ Removeable tank ■ Tank capacity: 2 liters ■ Heater wattage: 650 watts ■ Initial warm-up time: 5 minutes ■ Carrying handle ■ Remote: DMX-2 Timer interval & duration remote with 18" cable ■ DMX Channels: 1 ■ DMX In: 3 Pin XLR ■ Power: 120vAC 50/60Hz ■ Fuse: 10A ■ Size: 19.5"x 8.62"x7.7" ■ Weight: 7.1Kgs/15.62Lbs ■ Color: Black



Specifications are subject to change without notice.

ULTIMATE 3000 HAZE GENERATOR™

FM-ULTIMATE3000D (replaced FM-ULTIMATE3000)

SWEFOG
Technology Group AB

Haze Machines



Ultimate 3000DMX shown with 1.6ft air hose.

Ultimate 3000 DMX has the same high capacity as Ultimate 2000 DMX, but compressor and haze units are able to work separately. With the use of an extension hose up to 25m (82 ft), the compressor unit can be hidden away for silent operation. The haze unit, which can be placed directly on a theatre stage, contains Swefog's Whisper technology; the unit is designed vibration-free, and with lowest possible fan noise. The Ultimate 3000 DMX, with exciting design and state-of-the-art materials, is a premium hazer, that has become a benchmark representing the industry's best.

Specifications: Instant on, no warm up time ■ Continuous operation ■ Air compressor operation, no heat, no water ■ Mineral-oil based fluid ■ Extremely low fluid consumption (only .05 liters/0.01 US gal per hour) ■ full output. A 5L (1.3 U.S. gal) fluid canister will last for approx. 80 hours. ■ Stylish design and ergonomic carrying handle ■ Integrated DMX or stand alone control ■ One DMX channel control ■ Quick DMX address using digital display ■ Swefog V-tec type B 3 way high output vapor splitters ■ Swefog EC EasyClean nozzle and filter unit in & outlets are protected with an easily replaceable

filter, keeping internal parts clean. ■ Hydro-glass haze filter to recycle haze fluid back into tank ■ Five independent filter systems insures clean and safe haze ■ Auto-drain of condensation in air filter ■ Easy to read fluid level indicator ■ Long life Nexus piston compressor (MTBF 8000+ hours) ■ Air intercooler made with aluminum & copper ■ Forced ventilation by fan ■ Usually does not affect most fire alarm sensors ■ Comes fully loaded with two sets of air hoses & electric cables, 0.5m (1.6ft) & 10m (33ft). Optional 16m (53ft) & 25m (82ft) air hoses available ■ Power cons ■ Haze unit: 40 Watts Power cons. Compr 540 Watts ■ Compressor Unit, Net: Size: 16.4"x8"x11.5" ■ Weight: 14.7Kgs/32.4Lbs ■ Haze Unit, Net: Size: 15.5"x8"x13.2" ■ Weight: 11.9Kgs/26.2Lbs ■ Both Units together: Size: 6.4"x8"x22.6" ■ Weight: 26.6Kgs/58.6Lbs

ULTIMATE 2000 HAZE GENERATOR™

FM-ULTIMATE2000D

Industry standard for hazers - no other machine offers more value for your money. It creates a safe, dry, clean and virtually invisible haze, which enhances the beams from projected lights. The machine is made with no compromises, and offers quality in every single detail.

Features: High Output Hazer ■ Extremely Low Fluid Consumption ■ Built-in DMX512 Control ■ Haze Virtually Invisible Until It Is Illuminated ■ Outstanding Hang Time, 3+ Hours

Specifications: Instant on, no warm up time ■ Continuous operation ■ Air compressor operation, no heat, no water ■ Extremely low fluid consumption (only .06 liters per hour) ■ 3 hour haze hang time ■ Stylish design and ergonomic carrying handle ■ Integrated DMX or stand alone control ■ One DMX channel control ■ Quick DMX address using digital display ■ Swefog V-tec type B 3 way high output vapor splitters ■ Swefog EC EasyClean nozzle and filter unit ■ Hydro-glass haze filter to recycle haze fluid back into tank ■ Five independent filter systems insures clean and safe haze ■ Auto-drain of condensation in air filter ■ Easy to read fluid level indicator ■ Long life Nexus piston compressor (MTBF 8000+ hours) ■ Air intercooler made with aluminum & copper ■ Forced ventilation by fan ■ Usually does not affect most fire alarm sensors ■ Size: 8"x15.1"x15.2" ■ Weight: 18.5Kgs/40.8Lbs



XEON INTELLHAZER™

FM-HAZERXEON

The XEON Intellhazer is a high-power water based haze generator based on Swefog's X-power technology. It is simply the best water hazer on the market today!

Features: 1,800 W high output wide bore stainless steel heat exchanger ■ Specially developed fan turbine, with high capacity for large stages. Can also be operated extremely silent. ■ Manual, DMX 512, 0-10V, intelligent timer modes. ■ Advanced user defined sequence programming. ■ For best performance, use with specially formulated XTR Waterbased Haze Fluid. Order code **FF-ELITEHAZEX1W**.

Specifications: warm up time 7 minutes ■ Continuous operation ■ Smoke projection 45 degree angle, approx. 20 meters maximum ■ Fluid consumption 0-17.5ml / min (1,050 ml/h max) ■ 2.5L fluid capacity (Swefog MiniTrainer™) ■ Neutral-Pro water based fluid ■ 133mm/1,650rpm 100W high fan type ■ 2 DMX channels (1st output, 2nd fan) ■ Low fluid shutoff when completely empty ■ 120V 60Hz ■ Power consumption 1,800W/15A @ 120vAC ■ Size: 25.6"x18.5"x16.5" ■ Weight: 11Kgs/24.3Lbs



HAZER 2 WITH REMOTE

FM-HAZER2

Professional water-based hazer with fan control and DMX.

Specifications: Haze output: 3000 cubic/feet per minute ■ Tank capacity: 3.7 liters ■ Heater wattage: 600 watts ■ Initial warm-up: 8 minutes ■ Wired remote included ■ Stand-alone or DMX operation ■ DMX Channels: 2, Ch1-Haze output & Ch2-Fan speed ■ Dual carrying handles ■ Power consumed: 650 watts ■ Power: 120vAC 50/60Hz ■ Size: 15.6"x8.9"x15.75" ■ Weight: 12Kgs/ 26.4Lbs ■ Color: Black



HAZER Z150 WITH REMOTE

FM-HAZERZ150

The Hazer Z150 is a compact haze generator that produces a translucent medium to maximize and enhance beams of light without creating clouds of smoke. It uses a water-based fluid that is safe, easy to use, and does not leave any residue or sticky deposits on surrounding surfaces and lighting equipment. Produces approximately 1000 cubic feet per minute. It is virtually silent and provides an even dispersal of haze. Included remote controls the manual or automatic ON/OFF operation and the variable interval timer setting. Internal fluid tank.

Specifications: Power: 120vAC 50/60Hz at 4 Amps ■ Size: 15"x7"x6" ■ Weight: 3.9Kgs/8.5Lbs



Specifications are subject to change without notice.

Elite Fogging and Hazing Fluids

Elite™, Elite Pro™, Elite LL™, Elite QD™ and Elite HQD™ are high quality fogging fluids which can be used to create a white fog mist. Ranges of use include theaters, concerts, tours, clubs and all other entertainment venues where a safe, non-toxic visual medium is necessary to better define the visibility of lighting designs. The Elite™ Series of fluids are formulations of U.S.P. or high purity grade materials listed as non-hazardous by OSHA. Scientifically distilled water is used as the main component making it a water-based, low-flammable fogging fluid. By using distilled water and a filtering system, contamination of the fluid is kept to a minimal mineral concentration. Prior to filling containers, a final 1 micron dual filtering process insures a consistently pure mixture. Keeping contamination virtually non-existent helps extend the mean time between failure of fog machines thus reducing maintenance, down-time and costs.

Elite™ - Use Elite™ to create medium density clouds of fog - neutral scent, scenting option available

- One Quart (0.95L) **FF-ELITEQ**
- One Gallon (3.79L) **FF-ELITE1**
- 2.5 Gallons (9.46L) **FF-ELITE2**
- 5 Gallon Pail (18.93L) **FF-ELITE5**
- 55 Gallon Drum (208L) **FF-ELITE55**

Elite Pro™ - Performance formula - Use Elite Pro™ for higher density, longer lasting fog - neutral scent, scenting option available

- One Quart (0.95L) **FF-ELITEPROQ**
- One Gallon (3.79L) **FF-ELITEPRO1**
- 2.5 Gallons (9.46L) **FF-ELITEPRO2**
- 5 Gallon Pail (18.93L) **FF-ELITEPRO5**
- 55 Gallon Drum (208L) **FF-ELITEPRO55**

Elite LL™ - Elite LL™, when used with a cooling device (chiller) creates a low lying, quick dissipating fog effect. Without the chiller, Elite LL™ creates an extra quick dissipating fog.

- 2.5 Gallons (9.46L) **FF-ELITELL2**
- 55 Gallon Drum (208L) **FF-ELITELL55**

Elite QD™ - Use Elite QD™ to create quick dissipating medium density clouds of fog.

- One Gallon (3.79L) **FF-ELITEQD1**
- 5 Gallon Pail (18.93L) **FF-ELITEQD5**
- 55 Gallon Drum (208L) **FF-ELITEQD55**

Elite EQD™ - Use Elite EQD™ to create extra quick dissipating clouds of fog.

- 5 Gallon Pail (18.93L) **FF-ELITEEQD5**
- 55 Gallon Drum (208L) **FF-ELITEEQD55**

Elite HQD™ - Use Elite HQD™ to create quick dissipating higher density clouds of fog only.

- 5 Gallon Pail (18.93L) **FF-ELITEHQD5**
- 55 Gallon Drum (208L) **FF-ELITEHQD55**

Elite Haze™ - Elite Haze™ is non-toxic, odorless and offers a long lasting hang time. Elite Haze™ is filtered and utilizes pure grade chemicals to help prevent clogging and residue build-up. Use Elite Haze™ to create a finely hazed atmosphere only.

- One Gallon (3.79L) **FF-ELITEHAZE10** oil-based
- 55 Gallon Drum (208L) **FF-ELITEHAZE550** oil-based

- One Gallon (3.79L) **FF-ELITEHAZE1W** water-based
- 5 Gallon Pail (18.93L) **FF-ELITEHAZE5W** water-based

Elite XTR™ - Elite XTR™ water-based is non-toxic, odorless and offers a long lasting hang time.

- One Gallon (3.79L) **FF-ELITEHAZEX1W** water-based

Elite Foam™ - Use Elite Foam™ concentrate to produce 58 gallons of foaming solution. Dilute with water.

- One Gallon (3.79L) **FF-FOAM1**



Gallon

5 Gallon Pail



2.5 Gallons



Quart

elite^{LL}

elite^{QD}



55 Gallon Drum

ELITE SCENTS

Add a little scent to your fog. Concentrated scents for Elite and Elite-Pro are sold separately in individual 1 ounce bottles. Each bottle will scent up to 4 gallons of fog juice.

- SCENT-S** Strawberry
- SCENT-T** Tropical
- SCENT-E** Euro/original scent
- SCENT-P** Pina Colada
- SCENT-V** Vanilla



Specifications are subject to change without notice.

STROBE FLASH TUBE AND CONTROLLER

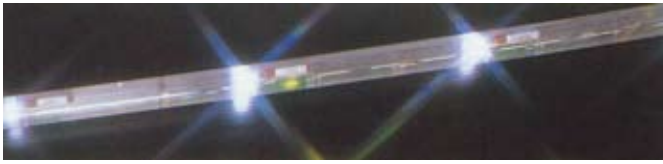

ST-TUBE2

These dynamic strobe tubes produce long bi-directional chases of intense pulse strobing. Each tube contains 4 individually firing strobe circuits. Each tube can be chained from one to the other with included connectors. Mounting clips included. Weather resistant for outdoor use. Controller sold separately.

Specifications: Tube length 5' by 2" diameter ■ Weight: 5Kgs/11Lbs

ST-TUBE2C1 Controller

Up to 25 tubes can be linked on one single controller. Offers 5 modes of operation: one way forward, one way backwards, reverse, circulation and combination mode. On/Off switch, speed and interval time control.

Specifications: Power: 120vAC 50/60hz ■ Size: 6.11"x4.33"x2" ■ Weight: 1Kgs/2.2Lbs



FLASHDOME STROBE



ST-FLASHDOME1

Flashdome provides powerful flashes from a stylish molded housing. Includes mounting bracket and strobe flash variable pot adjustable from 2 to 14 flashes a second. Can run stand alone or with remote control **ST-STROBEC103** or **C108**.

Specifications: Power: 120vAC 50/60Hz ■ Wattage: 45w with LST-BH0647 ■ Size: 13.8"x9.46"x9.46" ■ Weight: 2Kgs/4.4Lbs

OCTA STROBE

ST-STROBE4

Octagonal strobe box with 60 watt power flashes. Includes mounting bracket and variable speed adjustment from 2 to 14 flashes per second. Optional remote: **ST-STROBEC103** or **C108**.

Specifications: Power: 120vAC 50/60Hz ■ Size: 11"x5.1"x10.25" ■ Weight: 2.4Kgs/5.3Lbs ■ Lamp: LSTBH0647



MICRO STROBE BOX



ST-MICRO1

It's small but packs a punch. Miniature strobe with 20w xenon lamp and variable speed control from 1 to 10 flashes per second. Includes mounting bracket.

Specifications: Power: 120v-50/60Hz ■ Lamp: LSTAT367S ■ Size: 4.73"x3.15"x2" ■ Weight: .8Kgs/1.76Lbs

HANGING STROBE

ST-STROBEH

Standard AC plug with 2.5' cable. Comes in clear, flashes 1 per second.

Specifications: Size: 1.6"x3.8" ■ Weight: 200g/7oz



DMX SUPER STROBE

ST-ML504B-ML

Super powerful 1000 watt DMX strobe for professional applications. DMX controllable on two channels: dimming and flash rate. Mounting bracket included.

Specifications: Power: 120v-50/60Hz at 14 Amps ■ Wattage: 1000w with LSTXOP70/FTW-T ■ Size: 18.5"x7.25"x7.5" ■ Weight: 3.86Kgs/8.5Lbs ■ 3-Pin XLR input



SUPER BURST DMX STROBE

ST-STROBE750D

Strobe 750 produces 750w bursts of xenon flashes. Using DMX control allows the varying of intensity and rate of flash speed. DMX input via 3-pin XLR connection. Mounting bracket included.

Specifications: Power: 120vAC 50/60hz ■ Size: 15.5"x10"x6" ■ Weight: 4Kgs/8.8Lbs ■ Lamp: LST750



FLASHER DMX 1.5

ST-FLASHER1

Flasher DMX 1.5 is a professional strobe light that has a 1,500W xenon lamp with exceptional luminous power. Fitted in a sturdy powder-finish metal container, Flasher DMX 1.5 is built to ensure reliability under even the most extreme conditions. It operates on a continuous duty cycle without thermalling out.

Specifications: Flash rate: from 0 to 50fps (continuous light) ■ Dimmer adjustable from 0-100% ■ Single flash at maximum power ■ Universal power requirements and automatic power factor correction and, using just 2 DMX channels, it can be controlled by any controller ■ The built-in computer constantly monitors unit status and indicates any faults ■ The Flasher is remarkably powerful, approximately three times that of others of the same category. ■ Size: 7.87"x19.69"x8.66" ■ Weight: 6Kgs/13.2Lbs

ST-FLASHER1 Back



SMART CT-SMART

Smart Control is a DMX remote controller for the main functions of the flasher DMX 1.5. See page 34.



IDEA STROBE

ST-IDEASTROBE

IDEA Strobe is a professional strobe light fitted with a 1,500W xenon lamp with an exceptional luminous output.

Fitted in a sturdy metal case, IDEA STROBO is built according to CE norms and submitted to very strict tests that ensure its reliability even in the most extreme conditions.

Specifications: Flash rate from 1 to 25 flashes per second (continuous light). ■ Dimmer adjustable from 0 to 100% ■ Automatic operation master and slave ■ Sync with music ■ 4 pre-built programs ■ The universal power supply and automatic power factor correction system enable the unit to be used anywhere, and the DMX control (which only uses 2 channels) allow it to be run by any controller ■ Size: 7.87"x19.69"x8.66" ■ Weight: 6Kgs/13.2Lbs



FOUR CHANNEL STROBE CONTROLLER

ST-STROBEC108

Strobe controller outputs 4 different trigger channels. Each channel can link up to 8 strobes in series connection. Adjustable flash rate. Fits in rack.

Specifications: Size: 19.2"x3.75"x2.2" ■ Weight: 2Kgs/4.4Lbs



STROBE EGG

ST-EGG

The strobe egg is a powerful and compact strobe ball which can be screwed into any standard medium screw base lamp socket. It features a variable strobe adjustment knob for flash speed and a lamp rating of over 5 million flashes. Sold with clear dome. Optional colored replacement domes are available in red, blue, green and yellow.

Specifications: Size: 9.3"x9.3"x9.3" ■ Weight: .165Kgs/.4Lbs



STROBE CONNECTION CABLES

ST-STROBEC25: 25 feet 1/4" RTS cable
ST-STROBEC50: 50 feet 1/4" RTS cable
ST-STROBEC100: 100 feet 1/4" RTS cable



SINGLE CHANNEL STROBE CONTROLLER

ST-STROBEC103 ST-STROBE750R

Single channel strobe controller with adjustable speed and power on/off switch. **Specifications:** Power: 120vAC 50/60hz ■ Size: 5.12"x2.56"x5.91" ■ Weight: 1Kgs/2.2Lbs



DIGI-FAN WIND TUNNEL FAN

SE-WINDDIGIFAN



DigiFan is a powerful and versatile wind tunnel machine designed for professional TV studios, theatres, theme parks and concert venues. It is suitable for a wide range of applications including quick dispersion of fog and haze over long distances, creating special wind effects, scattering bubbles, confetti or snow, and even cooling performers during photo shoots.

It is extremely compact in size and weighs only 28 pounds. The supplied magnetic remote controlled box includes DMX settings, 9 program memory settings, speed control and turbo modes. The fan housing is constructed from a molded lightweight plastic with rugged tubular steel surroundings for transport protection and mounting. The 11" single part blade and spiral front grill create a very focused wind effect. The bracket can stand on the floor or be mounted using the 1/2 inch clamp hole.

Specifications: High velocity motor speed of 3500RPM ■ DMX Control: On/Off & variable speed control ■ DMX512 on 5 Pin XLR ■ Remote Control: 9 mode memory setting and variable speed fader ■ Full on touch turbo function from 0-3500RPM within 5sec ■ Air Volume: 1700CBM/hr ■ Wind Speed: 60KM/hr ■ Remote supplied w/3M standard cable, can be extended ■ Mounting: Self floor standing, or Clamp/Photo stand mountable ■ Power: 100-120v & 200-240vAC 50-60Hz w/On-Off switch on rear panel ■ Power: Max. 1200W, Current: 10A ■ Color: black ■ Size: 20" diameter x 22" height ■ Weight: 12.5Kgs/27.6Lbs

WIND TUNNEL

SE-WINDFAN/1



WindTunnel 500 fan can be used whenever you need artificial wind to create a mood on your stage, studio, theater or video/photo shoot. The tunnel shaped jet engine case produces a highly concentrated narrow stream of airflow. Can be used for dispersion of fog or haze effect on stages. User can adjust speed with the variable control slider.

Specifications: 145 watt motor ■ 60db Noise level ■ Wind volume: 100,000 cubic feet per hour ■ Tunnel diameter: 16" ■ Internal thermal cut-off ■ Electronic speed control ■ Detachable power cord ■ Current draw: 2 Amps ■ Power: 110-120vAC 50/60Hz ■ Size: 20.5"x12.25"x24" ■ Weight: 11Kgs/24Lbs

T-1600 EVAPORATIVE SNOW[®] MACHINE

SE-SNOWT1600



This futuristic modeled "work-horse" from Snowmaster™ sprays evaporative snow from its nozzle section and creates a realistic snowfall effect without residue or cold air. This is the quietest snow machine in the world. Designed for stage, movie productions, theatrical scenes, church events, and any performances where noise makes the difference, the T-1600 has a rating of 68 db @ 3 meters. DMX on-board with duty cycle timer (5 and 15 min repeat cycle timer) stand alone settings. US patent no. 6,868,691 **Features:** 4-channel DMX control ■ Variable stand alone features ■ Lifetime warranty ■ 24-Hour Technical Service ■ Repeat Cycle Timer (5 min. and 15 min. cycles)

Specifications: Discharges approximately 25-30 feet ■ 4 channel DMX Control using 5 pin XLR ■ Fluid Consumption: approximate 1 oz per minute ■ Container Size: 1 gallon ■ Sound Level: 68 db @ 9.8 feet ■ Polyethylene Exterior with steel covers, bracket and yoke. ■ Color: Black ■ Power: 110vAC 60Hz ■ Current draw: 10 Amps ■ Power cord: 7 feet ■ Size: 16"x48.5"x15"without yoke ■ Weight: 19.1Kgs/42Lbs

BUBBLE MACHINES

SE-BUBBLEM1

Ideal for parties, stage shows, night clubs or just plain fun. Medium output bubble machine.

Specifications: Power: 120vAC ■ Current Draw: 1.8 Amps ■ Size: 8.75"x8.75"x8.5" ■ Weight: 2.9Kgs/6.5Lbs



SE-BUBBLEM2

Ideal for stage shows, theme parks, and night clubs. High output bubble machine. Includes adjustable U-bracket and 1/2" clamp hole for mounting. Features an easily refillable and large removable reservoir for bubble fluid.

Specifications: Power: 120vAC ■ Current Draw: 1.8 Amps ■ Size: 16.5"x11"x8.5" ■ Weight: 5Kgs/11Lbs

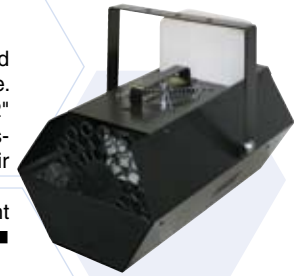

SE-BUBBLEM4

Our most professional bubble machine using 3 fans and 4 bubble wheels. Perfect for large areas and venues where lots of bubbles are needed quickly. Includes adjustable U-bracket and 3 x 1/2" clamp holes for mounting. Features a large stainless steel bubble fluid reservoir and side drain valve.

Specifications: DMX512 control using 1 on/off channel ■ DMX 5 pin XLR input ■ Dip switch addressable ■ Power: 120v ■ Current Draw: 2 Amps ■ Size: 16.5"x10"x8.3" ■ Weight: 10.4Kgs/23Lbs



SE-BUBBLEL1 Bubble Liquid – safe & non-toxic
1 gallon



SE-BUBBLEL55 Bubble Liquid – safe & non-toxic
55 gallon drum

SNOW MACHINE

SE-SNOW1

The Snow Machine creates a flurry of artificial snow flakes for staging, theatrical and show use. Uses non-toxic foaming liquid. With DMX, you can adjust the output or snow flake to enhance your scenes.



Specifications: Discharges approximately 10-15 feet ■ DMX Control: 1 or 2 channels ■ Remote Included: SRC-1 ■ Tank capacity: 5 Liters ■ Mounting yoke ■ Power: 120vAC 50/60Hz ■ Current draw: 10 Amps ■ Size: 24.02"x14.37"x14.37" ■ Weight: 12Kgs/26.4Lbs ■ Color: Black/Silver steel plate body

Elite Snow™ - Use Elite Snow™ to create a high volume of fluffy foam suds that are of a non-toxic, water-based solution.

One Gallon (3.79L)
55 Gallon Drum (208L)

SE-SNOWL1
SE-SNOW55

One Gallon (3.79L)

SE-SNOWFG100

The real secret to successful snow fall is the special ingredients in the PATENTED Evaporative Snow™ Liquid by Snowmaster™. One gallon produces up to 60 minutes of continuous snow depending on the desired size of the snowflake. One gallon produces up to 60 minutes of continuous snow depending on the desired size of the snowflake.

One Gallon (3.79L)

SE-SNOWGLOW

Snowmaster™ Exclusive - for glow under black light snow falls. Just add one or more 4 ounce bottles to one gallon of premix for UV reactant snow. UV reactant dries clear and leaves no residue. Safe to use anywhere.

Specifications are subject to change without notice.

BLACK LIGHTS



BL-48PRO This professional 48" black light metal fixture produces UV light using one 40w F40BLB bulb. Includes rear reflector, power cord and metal protection mesh grill.

Specifications: Power: 120vAC/60Hz ■ Size: 51.25"x5.3"x5" ■ Weight: 5.1Kgs/11.2Lbs



BL-48 This professional 48" black light metal fixture produces UV light using one 40w F40BLB bulb. Includes rear reflector, power cord and metal protection mesh grill.

Specifications: Power: 120vAC/60Hz ■ Size: 48"x5.25"x2" ■ Weight: 3.86Kgs/8.5Lbs



BL-18 The 18" black light fixture produces UV light. It is light weight and includes a F15T8/BLB bulb, power cord and on/off switch. Replaceable lamp. U.L. approved.

Specifications: Power: 120vAC/60hz ■ Size: 18"x4"x1.5" ■ Weight: .77Kgs/1.69Lbs

BLACKLIGHT BULBS

Black light blue bulbs are available in a variety of styles and sizes. They produce UV light which makes objects glow. BLB bulbs are a deep purple color and emit no white light. Available in fluorescent tubes: F40BLB, F36T8BLB, F20BLB, F8T5BLB, F6T5BLB, F4T5BLB, F15T8BLB, FCA21/BLB, H400BL. Incandescent E26 medium screw available in versions: 40T10BLB, 50R20BLB, 75A19BLB, 75R30BLB, 100G40BLB.



BLACKLIGHT 400PRO

BL-400

BL-400 is a compact, super high intensity 400w black light UV fixture with polished reflector and wire mesh protector. For professional use. Takes 5 minutes warm up to reach maximum brightness and provides wide dispersion coverage. Includes mounting bracket and power cord.

Specifications: Lamp: H400BL ■ Power: 120v/60Hz ■ Size: 7.25"x19.5"x10.25" ■ Weight: 13.2Kgs/29Lbs

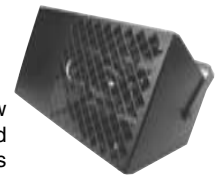

BLACKLIGHT UV 125W ROUND REFLECTOR SPOT

BL-125S

Specifications: Lamp: H125BL ■ Power: 120vAC/60Hz ■ Size: 8.85"x11.85"x12.75" ■ Weight: 7.7Kgs/17Lbs



BLACKLIGHT UV 400W ROUND REFLECTOR SPOT

BL-400S

Specifications: Lamp: H400BL ■ Power: 120v/60Hz ■ Size: 14.76"x15.27"x16.26" ■ Weight: 13.2Kgs/29Lbs



MIRROR BALLS & MOTORS

BALLMOTORDC1

Battery operated mirror ball motor. Uses 1 D-Cell 1.5v Battery. For use with 2"-12" mirror balls only. Runs over 72 hours on one Duracell Pro-Cell Battery.

Specifications: Dia: 1.75" x 5.5" ■ Weight: 96.4g/ 3.4oz



BALLMOTORSHD1

Super Heavy Duty mirror ball motor specifically designed to rotate our 30 and 40 inch mirror balls. Maximum load capacity of 94 Lbs. Square metal housing. 3 RPM rotation

Specifications: Power: 120vAC/60Hz ■ Size: 12"x7.75"x7.25" ■ Weight: 4.77Kgs/10.5 Lbs



BALLMOTOR3P

Economical mirror ball motor with plastic casing. Revolves at 3 RPM. Most popular for ball sizes from 2" to 12".

Specifications: Power 120vAC/60Hz ■ Dia: 4.75"x2" ■ Weight: 314.7g/11.1oz

BALLMOTOR3

Mirror ball motor for 2" to 16" mirror balls. Spins at 3 RPM. Metal housing with clamp mounting plate.

Specifications: Power: 115vAC, use BALLMOTOR3-2 for 115v. Dia: 4.25"x3" ■ Weight: .45Kgs/1Lbs



BALLMOTORHD1

Mirror ball motor for 16" to 20" mirror balls. Maximum load capacity of 16 Lbs. Round metal housing.

Specifications: 3 RPM rotation ■ Dia: 4.63"x3.25" high ■ Power: 120vAC/60Hz ■ Weight: .65Kgs/1.44Lbs

BALLMOTORHD2-3 3RPM

BALLMOTORHD2-1 1RPM

Mirror ball motor for 24" size or smaller. Maximum load capacity of 20 Lbs. Round metal housing. 3 or 1 RPM rotation (specify by code)

Specifications: Dia: 7.7"x5.75" high ■ Power: 120vAC/60Hz ■ Weight: .93Kgs/2.05Lbs



MIRROR BALLS

High quality glass mirror balls. Motors sold separately.

Item Code:	Size:	Tile:	Weight:
BALLMIRROR2	2"	5mm	37g/1.3oz
BALLMIRROR8	8"	10mm	.9Kgs/2Lbs
BALLMIRROR12	12"	12mm	1.81Kgs/4Lbs
BALLMIRROR16	16"	12mm	2.95Kgs/6.5Lbs
BALLMIRROR20	20"	15mm	4.76Kgs/10.5Lbs
BALLMIRROR24	24"	15mm	7.26Kgs/16Lbs
BALLMIRROR30	30"	17mm	16.1Kgs/35.5Lbs
BALLMIRROR40	40"	17mm	28.5Kgs/62.7Lbs

STANDS

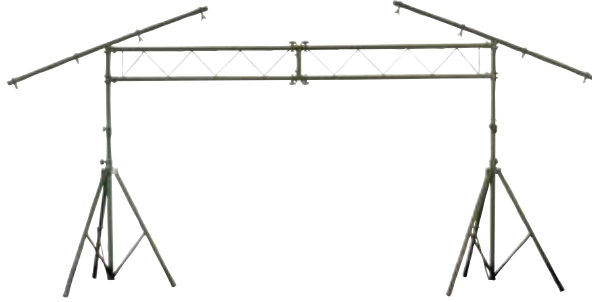

TR-LTS30 is a 10' portable trussing system, designed for easy set up and stability. It features two black aluminum tripods with safety locking pins and two 5' sections of "I" truss units which fit together to create a 10' span. Also included are two T-bars for additional mounting of fixtures on tripod tops. This stand system is ideal for Mobile DJs, bands and rentals.

Specifications: Weight: 17Kgs/37.4Lbs ■ Capacity: 90Kgs/198Lbs ■ Extends to a maximum height of 12 feet.

TR-LTS1 I-Truss 5' section



TR-LTS03

Compact, light duty stand with T cross bar for hanging par-cans, pin-spots, and smaller fixtures. Easy to transport.

Specifications: Maximum capacity: 30Kgs/66Lbs ■ Extends to 9 feet maximum ■ Weight: 1.8Kgs/4Lbs



TR-WINDUP2

Black wind up crank stand is adjustable from 70" to 116". Includes top cross bar.

Specifications: Maximum capacity: 45Kgs/100Lbs ■ Weight: 13.5Kgs/29.7Lbs



TR-LTS01 Heavy duty aluminum tripod stand with T bar and two side bars. Safe and economical. Easy to transport.

Specifications: Maximum capacity: 50Kgs/110Lbs ■ Extends to 13 feet maximum ■ Weight: 7.94Kgs/17.5Lbs



Made of chromed steel.

Model:	Sections	Height min/max	Weight	Base Spread	Mount
TR-4503	3	41"/92"	2Kgs/4.4Lbs	42"	Baby 5/8"
TR-4520	2	35"/108"	3.1Kgs/6.8Lbs	45"	Baby 5/8"
TR-4525	3	35"/139"	3.9Kgs/8.6Lbs	45"	Baby 5/8"
TR-4531	2	43"/130"	5.1Kgs/11.2Lbs	61"	Junior 1-1/8"

TR-TL4001

Professional heavy duty follow-spot tripod stand. Pivot sold separately. ■ Weight: 5.68Kgs/12.5Lbs



PIVOTS

TR-TL4007

Standard pivot attachment for TR-TL4001 stand.



TR-TL4014

Rotating pivot attachment for the TR-TL4001 stand. For very smooth and frictionless movements.



ELEVATOR

TR-EL03-LA

Elevator descends 3 meters or 9.9 feet. Maximum lift load weight is 80Kg/176Lbs.

Specifications: Power: 220vAC 50/60Hz ■ Size: collapsed 23.64"x 9.85"x12.2" ■ Weight: 42Kgs/92.5Lbs

BASE STANDS

Why use and lug around those heavy base weights? These lightweight aluminum base stands are perfect for par-cans and units which need to sit on the floor. A fixture is directly mounted to the floor base.



UltraLED DL-PANEL2-18U pg. 6 with TR-4584



TR-4583

Specifications: Color: black n Bolt: 3/8" ■ Diameter: 9-5/8" ■ Weight: .45Kgs/1Lbs

TR-4584

Specifications: Color: black ■ Bolt: 3/8" ■ Diameter: 5-5/8" ■ Weight: .27Kgs/.6Lbs



SAFETY CABLES

SAFETYCABLE18B 18" black w/lock

SAFETYCABLE18S 18" silver w/lock

SAFETYCABLE30B 30" black w/lock

SAFETYCABLE30S 30" silver w/lock

Every fixture that hangs overhead should always be equipped with a safety cable. In the event that a clamp should fail or is improperly tightened, a fixture could fall from the ceiling or truss and possibly cause personal injury or damage to equipment.



Specifications are subject to change without notice.

TRUSSING

TR-TRUSS

Aluminum trussing and truss structure systems are available in many types of configurations. Box, triangular, and ladder types are available in heavy and light duty weight. Circular truss shapes, square and custom designs are possible using a variety of sizes: 6", 9", 10", 12", 18" and 24". Trusses come in natural aluminum polished or may also be powder coated to specific colors for architectural applications. Call with specific application.

General purpose all aluminum 12" box trussing. Used for tradeshow booths, rentals, a/v and show rigging applications. Uses 4 bolts 5/8" diameter to mount to each other. This truss comes in natural aluminum polished or may also be powder coated to specific colors for architectural applications for an additional charge.

Construction:

- 12"x12" Outer Box Size
- 2" Outer Diameter 6061-T6 Aluminum Tubing Schedule 40
- wall thickness .125"
- 1.05" diameter cross brace tubing
- Rating: uniform distributed load UDL 855 pounds

TR-TRUSSB12-2 Box Truss 2'

Specifications: Size: 12 inch x 12 inch x 2 feet long
 ■ Weight: 10.9Kgs/24Lbs

TR-TRUSSB12-4 Box Truss 4'

Specifications: Size: 12 inch x 12 inch x 4 feet long
 ■ Weight: 14.1Kgs/31Lbs

TR-TRUSSB12-5 Box Truss 5'

Specifications: Size: 12 inch x 12 inch x 5 feet long
 ■ Weight: 15.9Kgs/35Lbs

TR-TRUSSB12-6 Box Truss 6'

Specifications: Size: 12 inch x 12 inch x 6 feet long
 ■ Weight: 17.7Kgs/39Lbs

TR-TRUSSB12-8 Box Truss 8'

Specifications: Size: 12 inch x 12 inch x 8 feet long
 ■ Weight: 20.90Kgs/46Lbs

TR-TRUSSB12-10 Box Truss 10'

Specifications: Size: 12 inch x 12 inch x 10 feet long
 ■ Weight: 25Kgs/55Lbs

TR-TRUSSB12-12 Box Truss 12'

Specifications: Size: 12 inch x 12 inch x 12 feet long
 ■ Weight: 30Kgs/66Lbs

TR-TRUSSB12C-6 6 Way Corner

Specifications: Size: 12 inch x 12 inch x 12 inch
 ■ Weight: 12.3Kgs/27Lbs

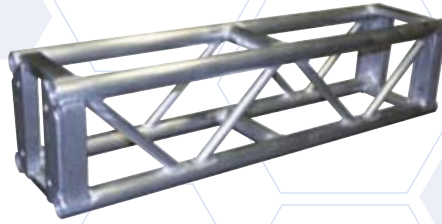

TR-TRUSSB12BP-24 BASEPLATE 24"

Specifications: Size: 24 inch x 24 inch x 2 inch
 ■ Weight: 22.7Kgs/50Lbs

TR-TRUSSB12BP-18 BASEPLATE 18"

Specifications: Size: 18 inch x 18 inch x 2 inch
 ■ Weight: 18.2Kgs/40Lbs

SANDBAGS

Sandbags for staging, theatrical and grip applications. Our industrial sandbags are manufactured using a high performance denier polyester canvas and stitched to mil-spec standards, using heavy duty bonded polyester thread for structural integrity. The high strength handles are made of polypropylene strap webbing, and sewn on using a military cross stitch and box pattern to ensure a durable and reliable attachment. All seams are double rolled for extra strength and made to endure the stress of production use, indoors and outdoors. Available in 15, 25, and 35 pounds and feature a weight label tag for quick visual weight identification. Equipped with plastic moisture linings which help in maintaining the precision weighed sand dry. Empty zipper self-fill types or sand filled. Color: Black

Center and Butterfly Handle Sandbag Two-In-One!



SB-S25CBF

SB-D40CDFB

Sandbag Donut 40Lbs Dual Handle Filled

SB-S15CBF

Sandbag Saddle 15Lbs Center and Butterfly Handle Filled

SB-S15CBZ

Sandbag Saddle 15Lbs Center and Butterfly Handle Zippered Empty

SB-S25CBF

Sandbag Saddle 25Lbs Center and Butterfly Handle Filled

SB-S25CBZ

Sandbag Saddle 25Lbs Center and Butterfly Handle Zippered Empty

SB-S35CBF

Sandbag Saddle 35Lbs Center and Butterfly Handle Filled

SB-S35CBZ

Sandbag Saddle 35Lbs Center and Butterfly Handle Zippered Empty



Donut Sandbag
SB-D40CDFB



FASTLOCK CLAMP

CLAMP-FASTLOCK

The "Fast-Lock" clamp is manufactured of aluminum and is designed to insure secure hanging of Giotto and Palco fixtures from truss bars or scaffolding with a pipe diameter of between 1.5 and 2 inches.

There are 8 slots on the underside of **SGM GIOTTO** fixtures for quick fitting the clamps, which may be positioned horizontally, vertically or at an angle of 15°, according to the fixture base.



TRUSS PICK POINTS

The Mega-Truss Pick is CNC machined from solid 1"x6" 6061 T-6 aluminum billet. Two pockets cut into the Mega-Truss Pick have coupler style aluminum pivoting links, half inch swivel bolts, and our solid wing nuts to completely wrap around the truss tube to secure it.

The Mega-Truss Pick has multiple shackle holes for attaching the truss to a shackle, motor, or chain hook. This allows for a center of lift adjustment for special situations. The Mega-Truss Pick can suspend up to one ton of truss load, plus an additional one ton load suspended under the truss. The Mega-Truss Pick weighs less than 4 pounds for the 12" truss version. Other models are available for 16", 18", 20.5", 24" and 30" truss.



CLAMP-TRP12MH

Specifications: 12" Truss pick ■ Safe Vertical Working Load - 1 ton truss / 2 ton total ■ Size: 1" thick x 6" tall x 13-3/8" long ■ Weight: 1.82Kgs/4Lbs ■ Color: Aluminum finish

CLAMP-TRP20MH

Specifications: 20.5" Truss pick ■ Safe Vertical Working Load - 1 ton truss / 2 ton total ■ Size: 1" thick x 6" tall x 21.9" long ■ Weight: 3.18Kgs/7Lbs ■ Color: Aluminum finish



CLAMP-TRP20

Specifications: 20.5" Truss pick ■ Safe Vertical Working Load - 1 ton truss / 2 ton total ■ Size: 1" thick x 6" tall x 21.9" long ■ Weight: 3.18Kgs/7Lbs ■ Color: Aluminum finish

CLAMP-C

Medium duty C-clamp. The most economical clamp available. Attaches to 1-2 inch pipe. Ideal for small effects, pin-spots and par-cans. Weight: .45Kgs/1Lbs



CLAMP-0055

Cube adapter for yoke mounting to tripod stands with Baby 5/8"

- Bolt: 3/8" diameter
- Size: 2.5"x2.25"x1.5"
- Weight: .15Kgs/0.33Lbs



CLAMP-MICRO/B Black
CLAMP-MICRO/P Polished Silver

Perfect for small fixtures like Par16s.

- Fits pipe sizes from 3/8" to 1"
- Capacity: 125Lbs
- Size: 4"x2.5"x.63"
- Weight: 0.1Kgs/.22Lbs



MINI CLAMP

The professional mini clamp comes in polished aluminum or black finish with a 3/8" mounting bolt. Used for pipe sizes ranging from 1/2" to 2" maximum. Capacity: 20Kgs/44Lbs



Weight: 172.94g/6.1oz
*X specifies finish: B-black, P-polished silver



CLAMP-4542

Heavy duty steel pipe clamp with 3/8" mounting bolt. Pipe diameter: 1" to 2.25" maximum. Weight: .91Kgs/2Lbs

CLAMP-HDQ

Heavy duty quick release clamp. Special mechanism allows clamp to release from fixture. For pipes sizes from 1 to 2 inches. Weight: .45Kgs/1Lbs



CLAMP-STEEL1

Heavy duty steel pipe clamp with 1/2" mounting bolt. Pipe diameter: 1" to 2" ■ Size: 6.75"x4.25"x2.13" ■ Weight: .94Kgs/2.07Lbs

CLAMP-O

Easily and safely attaches to round truss, pipe or light stand crossbars. Provides very solid grip without scratching or marring stand surface. Fits 1-1/2" and 2" tubes. Weight: .23Kgs/.5Lbs



MEGA CLAW

CLAMP-CLAW/P

The Mega-Claw was designed for intelligent lighting. The instant it is put over the pipe, the weight of the fixture is supported. Safe Vertical Working Load: 500kg/ 1,100 lbs ■ Size: 6"x4.375"x2" ■ Weight .9Kgs/2Lbs



CHEESEBOROUGH

Cheeseborough coupling clamps are a great way of rigging pipes and truss. Made of polished aluminum. Does not dent truss. Fastens onto 1.9" to 2" outer diameter pipes.

CLAMP-CBHALF/LP

Low profile single half coupler with 3/8" bolt mount.

- Size: 4"x3.3"x1.2"
- Load Capacity: 200 Lbs
- Weight: 0.15Kgs/0.34Lbs



CLAMP-CBHALF/N

Narrow width single half coupler with 3/8" bolt mount.

- Size: 4.5"x5"x1.2"
- Load Capacity: 650 Lbs
- Weight: 0.35Kgs/0.8Lbs



CLAMP-CBHALF

Single half cheeseborough coupler with 1/2" bolt mount.

- Size: 5.5"x4.5"x2"
- Load Capacity: 1100 Lbs
- Weight: 0.57Kgs/1.3Lbs



CLAMP-CBSWIVEL

Two halves which swivel/turn freely to any angle needed. CB Swivel can be locked in parallel 180 degrees, or perpendicular 90 degree positions using the included locking pin.

- Size: 7.5"x4.5"x2"
- Load Capacity: 1100 Lbs
- Weight: 1.07Kgs/2.4Lbs



CLAMP-CBRING

Single half coupler with a hook ring.

- Size: 5.5"x5.5"x2"
- Load Capacity: 1100 Lbs
- Weight: .6Kgs/1.3Lbs



MINI CLAW

CLAMP-CLAW/MINI/P

The Mini-Claw clamp is made of a lightweight high strength aluminum alloy. A quick locking jaw allows it to hold the weight of the fixture while fastening. The large aluminum T-handle with captive thrust washer makes it easy to tighten down firmly. Fits on outer diameter pipes from 1.66" to 2". Does not dent truss tubing. Maximum load capacity of 45Kgs/100Lbs. ■ Size: 5"x4.25"x2" ■ Weight .39Kgs/.86Lbs



Specifications are subject to change without notice.

MEGA CLAMP

CLAMP-MEGA/B Black - Anodized
CLAMP-MEGA/P Polished - Clear Anodized

This lightweight professional quality pipe clamp is made out of aluminum with the strength of steel. Designed for pipe sizes ranging from 1" to 2" maximum with 1/2" x 3" square head set bolt, 1/2" grade 5 hex head mounting bolt, and nickel plated steel Belleville spring washer for pan tensioning device. Safe vertical working load: 272Kgs/600Lbs ■ Size: 4"x6.3"x1" ■ Weight 13.8oz



CLAMP-TOOL

For professional pipe clamps, one tool can adjust 3 types of clamp bolts. Made of aluminum and only weighs 1.4 ounces. Size: 2-3/4" long.

CLAMP-4602

Crocodile grip clamp.



AIRWALL HANGERS

CLAMP-AIRWALLHANG

Alumalok is the industry standard for airwall track rigging. It is a tool for professional riggers, and for audio and video technicians trained in rigging for their specific applications. Utilize the built-in airwall track found in hotels, meeting rooms and venues around the world to hang lighting, speakers, cables, decor and more. Forget the time consuming hassles of more complicated rigging points and chain motors. Load rated at 750 lbs (340 kgs) UDL.



The Alumalok is designed to clamp to most airwall tracks with a slot opening of 1/2" to 1-1/2". The airwall track is captured between the body of the Alumalok and the two hardened steel gripping arms. This operation is accomplished via the steel thumb knobs and an optional allen wrench, minimizing the number of tools required, and eliminating the possibility of damaging the airwall track by over tightening. This is the only product endorsed for use in Marriott hotels worldwide. Made in the U.S.A.

Specifications: Load Rated: 750 UDL Working Load Rating ■ Safety factor of 7-1 minimum ■ Mounts to airwall tracks with an opening from 1/2" to 1-1/2" ■ Attachment points: Three 1/2" Bolt (13TPI) locations, two 5/8" Shackle holes, one 2" diameter clamp area ■ Size: 10"x8.5"x2" ■ Weight: 4.10Kgs/9Lbs ■ Color: Extruded aluminum silver finish

CLAMP-AIRWALLBLOK

AlumaBlok is designed as your number one solution for cable picks, wire rope assemblies and speaker dead hangs from airwall tracks. Load rated at 500 lbs (227 kgs) UDL this is the middle man of the ALUMALOK family!



Specifications: Load rated for 500 lbs. (227 Kg) UDL ■ Safety factor of 7-1 minimum ■ Solid CNC machined aluminum construction ■ Hardened STEEL grip arms ■ Single 1/2"-13 TPI threaded attachment points ■ Two 5/8" shackle points for dead hanging ■ Size: 6"x4.25"x2" ■ Weight: 2.04Kgs/4.5Lbs ■ Color: Extruded aluminum silver finish ■ Made in the U.S.A.

CLAMP-AIRWALLMINI

AlumaMini provides for safe and quick cable pick points across an airwall. Load rated at 250Lbs (113Kgs) UDL this is the mini of airwall track rigging.



Specifications: Load rated for 250 lbs. (113 Kg) UDL ■ Safety factor of 7-1 minimum ■ Solid CNC machined aluminum construction ■ Hardened STEEL grip arm ■ Two 1/2" shackle bolt attachment points ■ Size: 3"x4.25"x2" ■ Weight: 1Kgs/2.2Lbs ■ Color: Extruded aluminum silver finish ■ Made in the U.S.A.

MEGA AIRWALL TRACK HANGER 4"

CLAMP-AIRWALL4

The Mega Airwall Hanger 4" is 500 pound load rated. The Mega-Airwall Hanger will fit a wide variety of air wall tracks. The Mega Airwall Hanger engages the airwall track the full length of the hanger (4"). The Mega-Airwall Hanger panels move outward and apart at the top to engage the airwall track. The tops of the hanger panels have a continuous lip that rests on the load bearing portion of the airwall track.



These panels lock onto the track without damage to the track. Turning the center knurled wheel assembly easily expands the panels to lock the Mega Airwall Hanger into the track structure. The 1/8" hair pin safety is then applied to the wheel to lock the wheel rotation. This Mega Airwall Hanger has a center pocket location to clamp a light fixture, coupler, or attach slings. The Mega Airwall Hanger will fit into slot sizes from .8" to 2.25" wide and depths from .3" to 3". It will fit Hufcor type 11, 38, and 40 tracks, IAC .229", .313" and .500" tracks, Modernfold number 7, 10, 15, 16, 17, track, Panelfold type 5, 7, and 8 track, Emco Systems 8111, 8221, 8321, 8141, 8151, 8241, 8331, 9110, 9112, 9120, 9122, 8331, and 8431, Kwik-Wall Track with side by side carriers, and other manufacturer's tracks as well. The Mega Airwall Hanger will also fit Unistrut style channel. Made in the U.S.A.

Specifications: Load Rated: 500 lbs SVWL Working Load Rating ■ Safety factor of over 14 ■ Mounts to airwall tracks with an opening from 0.8" to 2.25" ■ Attachment point: one 1.9" diameter clamp area ■ Size: 4"x8.9"x2.25" ■ Weight: 1Kgs/2.2Lbs ■ Color: Extruded aluminum natural mil silver finish

MEGA AIRWALL TRACK HANGER 7"

CLAMP-AIRWALL7

The Mega Airwall Hanger 7" is 750 pound load rated. The Mega-Airwall Hanger will fit a wide variety of air wall tracks. The Mega Airwall Hanger engages the airwall track the full length of the hanger 7". The Mega-Airwall Hanger panels move outward and apart at the top to engage the airwall track. The tops of the hanger panels have a continuous lip that rests on the load bearing portion of the airwall track.



These panels lock onto the track without damage to the track. Turning the center knurled wheel assembly easily expands the panels to lock the Mega Airwall Hanger into the track structure. The 1/8" hair pin safety is then applied to the wheel to lock the wheel rotation. The Mega Airwall Hanger has a center pocket location to clamp a light fixture, coupler, or attach slings. Additionally this 7" model has two attachment holes. The Mega Airwall Hanger will fit into slot sizes from .8" to 2.25" wide and depths from .3" to 3". It will fit Hufcor type 11, 38, and 40 tracks, IAC .229", .313" and .500" tracks, Modernfold number 7, 10, 15, 16, 17, track, Panelfold type 5, 7, and 8 track, Emco Systems 8111, 8221, 8321, 8141, 8151, 8241, 8331, 9110, 9112, 9120, 9122, 8331, and 8431, Kwik-Wall Track with side by side carriers, and other manufacturer's tracks as well. The Mega Airwall Hanger will also fit Unistrut style channel. Made in the U.S.A.

Specifications: Load Rated: 750 lbs SVWL Working Load Rating ■ Safety factor of over 14 ■ Mounts to airwall tracks with an opening from 0.8" to 2.25" ■ Attachment points: Two 5/8" Shackle holes (0.88") and one 1.9" diameter clamp area ■ Size: 7"x8.9"x2.25" ■ Weight: 1.82Kgs/4Lbs ■ Color: Extruded aluminum natural mil silver finish

Specifications are subject to change without notice.

STAGEMAKER CHAIN MOTOR HOIST



MO-CH100-3P

STAGEMAKER COMPACT concert hoists run double duty for both concert staging and theatrical productions. R&M designed them to be small enough to fit into truss structures, quiet enough to run during theatrical performances, lightweight and durable enough for rigorous touring, and strong and accurate enough to position speakers, lighting systems, stage sets, and sceneries. R&M continuously consults entertainment industry professionals on what they need from their staging equipment and how best to improve the STAGEMAKER COMPACT line. The results have led to such features as a planetary gearbox utilizing grease lubricated precision gearing, which gives STAGEMAKER COMPACT hoists an average dB rating of less than 75dB; a large integral steel panel encasing all electrical components while giving you both easy access for maintenance and room for modifications; a heat treated load wheel with five full pockets to both minimize chain stress and ensure smooth operation; a chain guide to prevent the grade 80 black load chain from jamming no matter what position the hoist is in; a body of pressure-molded aluminum, which reduces the hoist's weight; heat sink ribs on the motor body for heat dissipation that lets you perform up to 240 starts per hour; folding handles for easy transport; 80-micron dark epoxy paint for added protection. Because of these features, STAGEMAKER COMPACT hoists are great basic workhorse chain motor hoists for everyday staging work.



MO-CH012-1P

Specifications/standard components: Class F insulated Hoisting Motor ■ Combined load limiter/brake ■ Electro-mechanical diskbrake ■ Solid-state brake control ■ 360 upper/lower hook rotation ■ Canvas chainbucket ■ Upright and inverted use* ■ Pressure cast aluminum body ■ 5-pocket load wheel ■ Anti-jam chain guide ■ Flexible handgrips ■ Black two-part epoxy paint ■ Power supply 115V 1ph 60Hz or 208,230, or 460V 3ph 60Hz *SM1 models only

SM2 STAGEMAKER HOIST

High power packed into a compact model, the SM2 has all the advantages of the SM5 in an SM1 body. In the world of the scenic arts, theatre, concert halls, exhibitions and trade shows you can now have the advantages of:

- a 1/4 ton (250 kg) load that can be lifted from a single fall!
 - a motor that weighs 40% less*
 - compact dimensions: down by 20%*
 - rotating upper hook
 - 208V or 230V-3Ph-60Hz power supply
- * in comparison to SM5



MO-CH025-SM2

Some STAGEMAKER COMPACT models available (For full list and additional options, contact Techni-Lux.)

Capacity	Product Code	Speed - 60Hz		Falls	Chain Size (mm)	Motor Power - 60		Dimensions	Weight (without chain)
		m/min	fpm			kW	Hp		
1/8 Ton	MO-CH012-1P	9.6	32	1	3.1x9.3	0.24	0.33	10.8"x7.8"x4.3"	14Kgs/30.8Lbs
1/4 Ton	MO-CH025-SM2	4.8	16	1	4x12	0.5	0.65	12.2"x8.5"x4.5"	17Kgs/34Lbs
1/4 Ton	MO-CH025-1P	4.8	16	1	4.8x12.5	1	1.33	15.7"x9.6"x5.26"	23Kgs/51Lbs
1/2 Ton	MO-CH050-1P	4.8	16	1	4.8x12.5	1	1.33	15.7"x9.6"x5.26"	23Kgs/51Lbs
1 Ton	MO-CH100-3P	4.8	16	1	6.8x17.8	2.1	2.8	18.9"x11"x6.82"	47Kgs/104Lbs

MC SERIES HOIST CONTROLLERS

Specifications: Power and control for electric chain hoists ■ Fully magnetic circuit breaker protection ■ Single phase or three phase configuration ■ Hand-held remote with 50 ft. cable ■ Available for up to 32 channels ■ Dual microprocessor design ■ ATA or Pelican® case ■ Front panel input phase indicators ■ Remote with individual "Bump" pushbuttons ■ Automatic shutdown if remote disconnects ■ Motor direction LED's on the remote ■ Available in rack mount version ■ Permanent install wall mount versions available



MC-803-7P

MC-PICKLE/L14-20

Product Code	Type	Phase	Output	Control Range
MC-401-7P	4-way Motor Controller	Single Phase CS63-75 Input	7 pin Socapex	50 foot remote
MC-403-7P	4-way Motor Controller	Three Phase CS83-75 Input	7 pin Socapex	50 foot remote
MC-801-7P	8-way Motor Controller	Single Phase CS63-75 Input	7 pin Socapex	50 foot remote
MC-803-7P	8-way Motor Controller	Three Phase CS83-75 Input	7 pin Socapex	50 foot remote
MC-PICKLE/L14-20	Pickle for Chain Motor Control	N/A	L14-20 Male	1.5 foot tail & L14-20

3-WAY U-GROUND TRIPLE TAP ADAPTOR T-STYLE 90 DEGREE

PC-515-3WAY/B

Specifications: 3-Way U-Ground Triple Tap Adaptor - T-style 90 degree with male 515P to 3 female 515R - All Black ■ Rating: UL and CSA ■ Size: 3.25"x3.0"x1.25" ■ Weight: 0.15Kgs/.32Lbs



Specifications are subject to change without notice.

HEAVY DUTY GROUNDED EXTENSION CORD

Heavy duty power extension cord. Ultra flexible 12/3SJTW cable with male to female Nema 5-15 edisons on each end. Outdoor water resistant and flame retardant. Great for professional use where a 12 gauge extension cord is needed for low power loss, high current or long runs. Used by A/V and production companies.

Specifications: Heavy Duty 12/3 Grounded Extension cord ■ Rated at: 15A, 125 volt, 1875w ■ Ultra flexible, flame retardant and water resistant SJTW ■ Male/Female edison Nema 5-15 ■ cULus & OSHA Approved ■ Color: Black

PC-EXT12/3E025B

- Length: 25 feet
- Weight: 1.4Kgs/3Lbs

PC-EXT12/3E050B

- Length: 50 feet
- Weight: 2.73Kgs/6Lbs

PC-EXT12/3E100B

- Length: 100 feet
- Weight: 5.5Kgs/12Lbs



XLR CABLES

Male to female XLR cables for DMX data use. The 3-pin XLR cables may also be used as LO-Z microphone cables. Specifications: Flexible black PVC jacket ■ UL2696 ■ Individually packaged ■ Black XLR Connectors with gold contacts ■ Suitable for permanent install and production use. Call for pricing on touring grade cables.

CA-XLR3/1	XLR 3-Pin Female to 3-Pin Male Cable - 1 foot
CA-XLR3/5	XLR 3-Pin Female to 3-Pin Male Cable - 5 feet
CA-XLR3/10	XLR 3-Pin Female to 3-Pin Male Cable - 10 feet
CA-XLR3/25	XLR 3-Pin Female to 3-Pin Male Cable - 25 feet
CA-XLR3/50	XLR 3-Pin Female to 3-Pin Male Cable - 50 feet
CA-XLR3/100	XLR 3-Pin Female to 3-Pin Male Cable - 100 feet

CA-XLR5/1	XLR 5-Pin Female to 5-Pin Male Cable - 1 foot
CA-XLR5/5	XLR 5-Pin Female to 5-Pin Male Cable - 5 feet
CA-XLR5/10	XLR 5-Pin Female to 5-Pin Male Cable - 10 feet
CA-XLR5/25	XLR 5-Pin Female to 5-Pin Male Cable - 25 feet
CA-XLR5/50	XLR 5-Pin Female to 5-Pin Male Cable - 50 feet
CA-XLR5/100	XLR 5-Pin Female to 5-Pin Male Cable - 100 feet



CA-XLR3/100



CA-XLR5/5



CA-XLR3/1

XLR CONNECTORS

XLR connectors are available in a variety of configurations and pin numbers. All connectors have nickel plating for reliable connections. The adapters now come in black body finish. 3-pin XLRs are commonly used in the audio industry and in the lighting industry for DMX data connection. 5-pin XLRs are also very popular for lighting industry data connections. 5-pin plugs are the "true" USITT DMX512 lighting standard, although many manufacturers have elected to use 3-pin for flexibility and availability.

When converting from 3 to 5 pin, it is important that Pin 1 remains the shield/ground. Pins 2 and 3 both remain the same in both connectors. In the 5-pin connector, pins 4 & 5 remain unused when converting. Our handy adapters provide proper conversions.

CO-XLR3MTO5F Adapter for DMX lighting applications, to go from 3-pin male to 5-pin female

CO-XLR5MTO3F Adapter for DMX lighting applications, to go from 5-pin male to 3-pin female

CO-XLRTERM3 Three pin DMX terminator-XLR male

CO-XLRTERM5 Five pin DMX terminator-XLR male

CO-XLR3F In-line 3-Pin Female XLR

CO-XLR3FP Panel mount 3-Pin Female XLR

CO-XLR3M In-line 3-Pin Male XLR

CO-XLR3MP Panel mount 3-Pin Male XLR

CO-XLR5F In-line 5-Pin Female XLR

CO-XLR5FP Panel mount 5-Pin Female XLR

CO-XLR5M In-line 5-Pin Male XLR

CO-XLR5MP Panel mount 5-Pin Male XLR



CO-XLR5MTO3F
XLR Adapter 5 Pin
Male to 3 Pin Female



CO-XLR3MTO5F
XLR Adapter 3 Pin
Male to 5 Pin Female



CO-XLR5F
XLR 5-Pin Connector
Female



CO-XLR3FP
XLR 3-Pin Panel
Mount - Female



CO-XLR5MP
XLR 5-Pin Panel
Mount - Male

POWER CABLES

PC Series

Heavy duty power cables are available in standard and custom configurations.



PC-12/14S-025

Standard Socapex 19-pin male to female in multi-conductor cable 12/19 and 12/14 exist in 25, 50, 75, and 100 foot lengths. Provides six circuits of power. Our cables are labeled with the length for easy identification and include 6 inches of heat shrink for company name placement.

PC-BI-S-06-EDISON

Break-In Socapex, 19 Pin F to Edison M, 6', 12/3, Black

PC-BI-S-06-L620

Break-In Socapex, 19 Pin F to L620 M, 6', 12/3, Black

PC-BI-S-06-S3PIN

Break-In Socapex, 19 Pin F to S3Pin M, 6', 12/3, Black

PC-BO-S-06-EDISON

Break-Out Socapex, 19 Pin M to Edison F, 6', 12/3, Black

PC-BO-S-06-L620

Break-Out Socapex, 19 Pin M to L620 F, 6', 12/3, Black

PC-BO-S-06-S3PIN

Break-Out Socapex, 19 Pin M to S3Pin F, 6', 12/3, Black

MOTOR CONTROL & POWER CABLES

PC-14/7S7PIN-025

14/7, Male/Female Socapex 7 Pin, 25', Black

PC-14/7S7PIN-050

14/7, Male/Female Socapex 7 Pin, 50', Black

PC-14/7S7PIN-075

14/7, Male/Female Socapex 7 Pin, 75', Black

PC-14/7S7PIN-100

14/7, Male/Female Socapex 7 Pin, 100', Black

POWER MULTI-CABLES

PC-12/14S-025

Socapex Male to Female 19 pin, 12/14, 25', Black

PC-12/14S-050

Socapex Male to Female 19 pin, 12/14, 50', Black

PC-12/14S-075

Socapex Male to Female 19 pin, 12/14, 75', Black

PC-12/14S-100

Socapex Male to Female 19 pin, 12/14, 100', Black

POWER CABLES

PC-12/3SO-250

12/3SO Power Cable, 12AWGx3, 250', Black



POWER CONNECTORS

Industrial grade construction and an all black ribbed nylon housing provides excellent impact resistance and hides well on stages and in theaters. The connector housings are beveled to prevent the connector from catching on stairs or equipment. Oversized mechanical clamp traps cord for exceedingly strong grip, eliminating strain on terminals. These plugs are quick and easy to install with wire entrance holes that are close together. Terminal screws are color coded for safety and provided in the "open" position for quick wire install. All devices are UL listed and CSA certified.



TWIST LOCKING DEVICES

CO-L515F Twistlock 4729 15a 125v Female Receptacle Black
CO-L515M Twistlock 4720 15a 125v Male Plug Black

CO-L520F Twistlock 2313 20a 125v Female Receptacle Black
CO-L520M Twistlock 2311 20a 125v Male Plug Black

CO-L530F Twistlock 305CBL 2613 30a 125v Female Plug Black
CO-L530M Twistlock 2613 30a 125v Male Plug Black

CO-L615F Twistlock 4579 15a 250v Female Receptacle Black
CO-L615M Twistlock 4570 15a 250v Male Plug Black

CO-L620F Twistlock 2323 20a 250v Female Receptacle Black
CO-L620M Twistlock 2321 20a 250v Male Plug Black

CO-L630M Twistlock 2623 30a 250v Male Plug Black

CO-L1420F Twistlock 2014C 2413 20a 125/250v 3 pole 4 wire Female
CO-L1420M Twistlock 2014P 2411 20a 125/250v 3 pole 4 wire Male

CO-L1520F Twistlock 2015C 2423C 20a 250v 3 pole 4 wire Female
CO-L1520M Twistlock 2015P 2421P 20a 250v 3 pole 4 wire Male

NEMA L5-15R
 NEMA L5-15P

NEMA L5-20R
 NEMA L5-20P

NEMA L5-30R
 NEMA L5-30P

NEMA L6-15R
 NEMA L6-15P

NEMA L6-20R
 NEMA L6-20P

NEMA L6-30P

NEMA L14-20R
 NEMA L14-20P

NEMA L15-20R
 NEMA L15-20P



EDISON BLADE DEVICES

CO-515F Standard Edison 5269 15a 125v Female Black
CO-515M Standard Edison 5266 15a 125v Male Plug Black

CO-520F Edison 5369 20a 125v Female Receptacle Black
CO-520M Edison 5366 20a 125v Male Plug Black

CO-615F 5669 15a 250v Female Connector Receptacle
CO-615M 5666 15a 250v Male Connector Plug

CO-620F 5469 20a 250v Female Connector Receptacle
CO-620M 5466 20a 250v Male Connector Plug

NEMA 5-15R
 NEMA 5-15P

NEMA 5-20R
 NEMA 5-20P

NEMA 6-15R
 NEMA 6-15P

NEMA 6-20R
 NEMA 6-20P

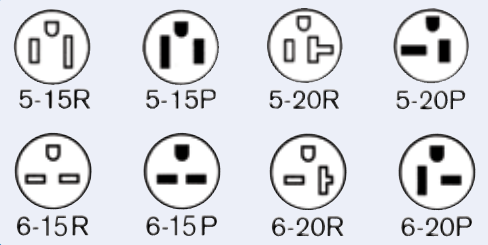

STAGE PIN DEVICES

Highest quality, Bates 20, 60, 100 Amp stagepin plugs available.

CO-STAGE20FBK Stage 3 Pin 20A Inline Female Black
CO-STAGE20FCC Stage 3 Pin 20A Inline Female Clear
CO-STAGE20FPM Stage 3 Pin 20A Female Panel Mount
CO-STAGE20MBK Stage 3 Pin 20A Inline Male Black
CO-STAGE20MCC Stage 3 Pin 20A Inline Male Clear

CO-STAGE60FBK Stage 3 Pin Bates 60A 125v Inline Female Black
CO-STAGE60FPM Stage 3 Pin Bates 60A 125v Female Panel Mount
CO-STAGE60MBK Stage 3 Pin Bates 60A 125v Inline Male Black

CO-STAGE100F Stage 3 Pin Bates 100A 125v Inline Female Gray
CO-STAGE100FPM Stage 3 Pin Bates 100A 125v Female Panel Mount
CO-STAGE100M Stage 3 Pin Bates 100A 125v Inline Male Gray
CO-STAGE100FH-PH Stage 3 Pin Group5 100A 250v Inline Female Phenolic Yellow Double Set Screw
CO-STAGE100MH-PH Stage 3 Pin Group5 100A 250v Inline Male Phenolic Yellow Double Set Screw



Power Split Adapters

Adapters are ready to wire devices

PC-PSY12/3-24: 12/3 SO Cable 24"
PC-PSY12/3-36: 12/3 SO Cable 36"

PC-PSW12/3-24: 12/3 SO Cable 24"
PC-PSW12/3-36: 12/3 SO Cable 36"



CO-POWERCONM
 Locking 3 pole power in connector. Fast and easy locking system with a high current capacity of 20 Amps. Neutrik NAC3FCA, blue color body. Power: 250v AC max

Specifications are subject to change without notice.

CAM TYPE DEVICES

Cam-type waterproof locks built for reliable service under all conditions with Advanced Devices signature integrity of design and quality construction, the new CLS Series is NEMA 3R and 4 rated for weather tight construction, CSA and CUS listed 400A/600V and meets 1999 NEC standards for locking connectors.



- CO-CLS2FXX** Cam #6-#2 Connector Female
- CO-CLS2MXX** Cam #6-#2 Connector Male
- CO-CLS40FXX** Cam 4/0 Connector Female
- CO-CLS40MXX** Cam 4/0 Connector Male
- CO-CLS40T020** Cam Wire Reducer 4/0 to 2/0

MINI CAMS

- CO-CLM2FXX** Mini Cam #8 - #2 female connector
- CO-CLM2MXX** Mini Cam #8 - #2 male connector



XX in product code represents color: BK-Black; BL-Blue; GR-Green; RD-Red; WH-White

PANEL MOUNT CAMS

- CO-CL40FRBXX** Panel Mount 2/0 - 4/0 Double Set Screw Female
- CO-CL40MRBXX** Panel Mount 2/0 - 4/0 Double Set Screw Male
- CO-CL40FRSBXX** Panel Mount 4/0 Stud Female
- CO-CL40MRSBXX** Panel Mount 4/0 Stud Male



- CO-CL40FRBBL**
- CO-CL40MRBBK**
- CO-CL40FRSBGR**
- CO-CL40MRSDRD**

CAM ADAPTERS

- CO-CLCTTXX** Tapping T Male-Female-Female Cam
- CO-CLCPTXX** Parallel T Female-Male-Male Cam
- CO-CLCDMMXX** Coupling Turnaround Male-Male Cam
- CO-CLCDFXX** Coupling Turnaround Female-Female Cam
- CO-CLCA3FSTA** Cam Soft 3-way
- CO-CLCA3FA** Cam 3-way



- CO-CLCTTBK**
- CO-CLCPTBK**
- CO-CLCA3FA**
- CO-CLCA3FSTA**

SOCAPEX 19 PIN CONNECTORS



- CO-19PIN-IF** Socapex 19 pin Inline Female Connector SLGFFDR419AR
- Size: 2.5"x2" dia
- Weight: 0.23Kgs/0.5Lbs



- CO-19PIN-PF** Socapex 19 pin Panel Mount Female Connector SLGEF419AR
- Size: 2.19"x2.19"x1"
- Weight: 0.11Kgs/0.25Lbs



- CO-19PIN-PFT** Socapex 19 pin Panel Mount Female Connector with 2' THHC cable tail, labeled - All Black
- Size: 25"x2.19"x2.19"
- Weight: 0.90Kgs/2Lbs



- CO-19PIN-IM** Socapex 19 pin Inline Male Connector SLGFM-DR419AR
- Size: 3.5"x2.5" dia
- Weight: 0.27Kgs/0.6Lbs



- CO-19PIN-PM** Socapex 19 pin Panel Mount Male Connector SLE-ME419AR
- Size: 2.25"x2.25"x1.25"
- Weight: 0.1615Kgs/0.3562Lbs

ROPE LIGHTING

RL-ROPE LIGHTING



Solid PVC flexible rope lighting is used for thousands of applications ranging from stage outlining, architectural wall high lighting, decorative motifs, to safety lighting for staircases.

- Specifications:** Long life span: average 35,000 hours ■ High pressure/crush resistant PVC ■ Temperature resistant 40°C to 105°C ■

Low power consumption ■ Various voltages: 12v, 24v, 120v, 230v ■ U.L. listed.

RL-IF65 Series: Standard round is offered in 1/2" and 3/8" diameters. Can be cut every 18 inches. Colors: Clear, Blue, Green, Orange, Pink, Purple, Yellow, Red, White, Pearl Blue, Pearl Green, Pearl Yellow, Pearl Red, Fluorescent Green, Fluorescent Orange.

RL-CF5 Series: 4 Channel multi-chasing round offered in 5/8" diameter. Can be cut every 6 feet. Colors: Clear/Clear, Clear with RGBY bulbs.

RL-CF4 Series: 3 Channel multi-chasing round offered in 5/8" diameter. Can be cut every 5 feet. Colors: many combinations

RL-CF65 Flex Rope Chasing 2 Channel 3 wire 1/2" diameter 120v 4' - SPEC COLOR

RL-CF65AC1 Flex Rope Chasing 2 Channel 3 wire AC Power and Cord Connector

RL-CF65AC3 Flex Rope Chasing 2 Channel 3 wire Splice Connector

LED ROPE LIGHTING

Solid PVC flexible LED rope lighting is used for thousands of applications ranging from stage outlining, architectural wall high lighting, cove lighting, decorative motifs, to safety lighting for staircases. Easy to bend and shape. LED ropelighting uses less energy than traditional incandescent ropelighting. LED bulbs also last much longer and produce little heat. Spool length: 150 feet.

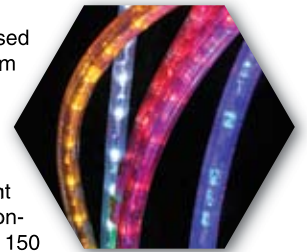

- Specifications:** Long life span: average 100,000 hours ■ 2.4w power consumption per 36" section ■ High impact/crush resistant PVC ■ Temperature resistant 40°C to 105°C ■ Low power consumption ■ Various voltages: 12v, 24v, 120v, 230v ■ U.L. / CSA Listed. ■ 1/2" diameter ■ Size: 36"x.042"x.042" ■ Weight: .1Kgs/.22lbs ■ Color: Clear

Blue, Green, White - Cutting size 3 feet, maximum run 600 feet

RL-IF65LBL Blue 1/2" 120v LED Rope

RL-IF65LGR Green 1/2" 120v LED Rope

RL-IF65LCW White 1/2" 120v LED Rope

Red, Yellow - Cutting size 4.5 feet, maximum run 900 feet

RL-IF65LRD Red 1/2" 120v LED Rope, cutting size 4.5 feet

RL-IF65LYE Yellow 1/2" 120v LED Rope, cutting size 4.5 feet

RL-IFLAF106 AC power cord and connector with rectifier

Options also available: in-line connectors, T-split and Y-split connectors, controllers, end caps, power cords, extensions, mounting clips and clear mounting track in 3/8", 1/2" and 5/8" widths.

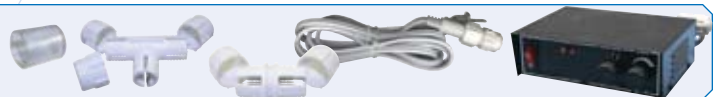

Gobos

Metal, glass and dichroic gobos in all sizes. Custom and standard patterns. Specify pattern, fixture and gobo size when ordering. Lead times and camera ready art are required.

Code:	Description
GOBO-CRUSHDIC GOBO-CRUSHDICE	Crushed Dichroic Enhanced Crushed Dichroic
GLASS GOBOS GOBO-GLABW1CUS GOBO-GLABW1DUP GOBO-GLABW1STD	Glass B&W or 1 Color Custom Original Glass B&W or 1 Color Custom Duplicate Glass B&W Standard Super Resolution
GOBO-GLA2CCUS GOBO-GLA2CDUP GOBO-GLA2CSTD	Glass 2 Color Custom 1st Original Glass 2 Color Custom Duplicate Glass 2 Color Standard
GOBO-GLACSCUS GOBO-GLACSDUP GOBO-GLACSTD	Glass Full Color Scenic Custom Original Glass Full Color Scenic Duplicate Glass Color Scenic Standard
METAL GOBOS GOBO-METCUS1ST GOBO-METCUSDUP	Custom Original Metal Custom Duplicate Metal
GOBO-METSTD1ST GOBO-METSTDUP	Standard Pattern Metal 1st Standard Pattern Metal Duplicate
GOBO HOLDERS GOBO-HOLDGS4B	Gobo Holder Source 4 Glass Size B
GOBO-HOLDM360Q GOBO-HOLDMGS4B	Gobo Holder 360Q Metal Size 2-3/4" Gobo Holder Source 4 Metal & Glass Size B
GOBO-HOLDMLEO GOBO-HOLDMS4B	Gobo Holder NSI LEO Metal, Size 3-1/8" Gobo Holder Source 4 Metal Size B



GOBO HOLDERS

GOBO-HOLDMGS4B

Gobo Holder is made from quality aluminum material with a durable handle (lifetime replacement guarantee if handle breaks). The Gobo Holder easily converts to hold both metal or glass patterns. Pop-out the retaining ring and insert the gobo and replace the ring. Holds "A" or "B" (79mm) glass. A-Open Area: 2-3/4" and B-Width: 3-11/16"



Specifications: Holds "A" or "B" sized glass and metal patterns ■ Fits slot size of 3/16" ■ Made of machined aluminum ■ Size: 9.375"x3.75"x0.25" ■ Weight: 0.142Kgs/0.313Lbs

Visit our website www.techni-lux.com
for more information on GOBOS and GOBO HOLDERS.

GOBO PROJECTORS

ROTOGOBO 250 EL-ROTOGOBO250

The RotoGobo 250 is a must for displays, exhibitions, shop windows, nightclubs and pubs. It projects gobo patterns with or without color, which can rotate and change automatically or via DMX. Using the dip switches, stand alone operation allows setting of interval gobo change time, rotating speed, and rotation direction in various increments without the need for a controller. With a DMX controller, channel one controls which gobo is selected, and channel 2 chooses the direction and speed of rotation. All gobos are interchangeable. Custom gobos may be ordered for this fixture. Focusable using manual turn Lens.

Specifications: ELC 250w 24v Lamp ■ 7 interchangeable gobos included ■ Uses glass or metal gobos ■ Gobo size: 25mm diameter, image area 18mm ■ DMX control via 2 channels ■ 3-Pin XLR input for DMX ■ Power: 120v-50/60Hz ■ Current Draw: 3.15 Amps ■ Color: Black ■ Size: 11.1"x8.7"x6.3" ■ Weight: 6.4Kgs/14.1Lbs



GOBO PROJECTOR TH-GOBO1B

Our most compact and lightweight single gobo pattern projector. Very effective when used in multiples. Great for store displays, night clubs, tradeshows and applications where a company logo or brand name may need to be projected. Uses 50mm diameter gobos. Manual turn focus lens. Custom gobos may be ordered.

Specifications: FNV MR16 50w 12v Lamp ■ Metal or plastic slide type gobo ■ Gobo size: 50mm diameter, image area 27mm ■ Forced fan cooling ■ Power: 120v-50/60Hz ■ Current Draw: 0.7 Amps ■ Size: 11.1"x3.76"x3.93" ■ Weight: 1.5Kgs/3.3Lbs ■ Color: Blue





UltraGel

Large Color Selection ■ Surface Coated on Both Sides ■ Wide Range of Filters ■ Long Lasting ■ 21" x 24" Sheets ■ High Color Stability ■ Direct Number Color Cross ■ Flame Retardant ■ Batch to Batch Uniformity

EXPENDABLES

Specifications are subject to change without notice.

- | | | | |
|-----------------------|--------------------------|---------------------------------|---------------------------|
| 002 Rose Pink | 132 Medium Blue | 218 1/8 C.T. Blue | 363 Special Medium Blue |
| 003 Lavender Tint | 134 Golden Amber | 219 Fluorescent Green | 366 Cornflower |
| 004 Med Bastard Amber | 135 Deep Golden Amber | 220 White Frost | 371 Light Green |
| 007 Pale Yellow | 136 Pale Lavender | 221 Blue Frost | 378 Yellow Green |
| 008 Dark Salmon | 137 Special Lavender | 223 1/8 C.T. Orange | 380 Golden Amber |
| 009 Pale Amber Gold | 138 Pale Green | 224 Daylight Blue Frost | 381 Rose Purple |
| 010 Medium Yellow | 139 Primary Green | 225 N.D. Frost | 382 Medium Purple |
| 013 Straw Tint | 140 Summer Blue | 226 U.V. | 383 Light Green Blue |
| 015 Deep Straw | 141 Bright Blue | 228 Brushed Silk | 384 Sky Blue |
| 017 Surprise Peach | 142 Pale Violet | 229 Quarter Tough Spun | 385 Deeper Blue |
| 019 Fire | 143 Pale Navy Blue | 230 Super Correction LCT Yellow | 386 Dark Bastard Amber |
| 020 Medium Amber | 144 No Color Blue | 232 Super White Flame | 410 Opal Frost |
| 021 Gold Amber | 147 Apricot | 236 H.M.I. To Tungsten | 416 3/4 White Diffusion |
| 022 Dark Amber | 148 Bright Rose | 237 C.I.D. To Tungsten | 441 Full C.T. Straw |
| 024 Scarlet | 151 Gold Tint | 238 C.S.I. To Tungsten | 442 Half C.T. Straw |
| 025 Sunset Red | 152 Pale Gold | 241 Fluorescent 5700K | 443 Quarter C.T. Straw |
| 026 Bright Red | 153 Pale Salmon | 242 Fluorescent 4300K | 444 Eighth C.T. Straw |
| 027 Medium Red | 154 Pale Rose | 243 Fluorescent 3600K | 450 3/8 White Diffusion |
| 029 Plasa Red | 156 Chocolate | 244 Plus Green | 452 1/16 White Diffusion |
| 033 No Color Pink | 157 Pink | 245 1/2 Plus Green | 702 Special Pale Lavender |
| 035 Light Pink | 158 Deep Orange | 246 1/4 Plus Green | 704 Lily |
| 036 Medium Pink | 159 No Color Straw | 247 Minus Green | 705 Lily Frost |
| 039 Pink Carnation | 161 Slate Blue | 248 1/2 Minus Green | 707 Ultimimate Violet |
| 046 Dark Magenta | 162 Bastard Amber | 249 1/4 Minus Green | 709 Electric Lilac |
| 048 Rose Purple | 164 Flame Red | 250 1/2 White Diffusion | 711 Cold Blue |
| 052 Light Lavender | 165 Daylight Blue | 251 1/4 White Diffusion | 712 Bedford Blue |
| 053 Pale Lavender | 166 Pale Red | 252 1/8 White Diffusion | 713 J. Winter Blue |
| 058 Lavender | 169 Lilac Tint | 253 Ultra-Frost | 714 Elysian Blue |
| 061 Mist Blue | 170 Deep Lavender | 255 Hollywood Frost | 715 Cabana Blue Get |
| 063 Pale Blue | 172 Lagoon Blue | 256 Half Light Frost | 716 Mikkell Blue |
| 068 Sky Blue | 174 Dark Steel Blue | 257 Quarter Light Frost | 717 Shanklin Frost |
| 071 Tokyo Blue | 176 Loving Amber | 269 Thermal Heat Shield | 718 Half Shanklin Frost |
| 075 Evening Blue | 179 Chrome Orange | 278 1/8 + Green | 719 Color Wash Blue |
| 079 Just Blue | 180 Dark Lavender | 279 1/8 Minus Green | 720 Durham Daylight Frost |
| 085 Deeper Blue | 181 Congo Blue | 280 Black Aluminum Wrap | 721 Berry Blue |
| 088 Lime Green | 182 Light Red | 281 3/4 C.T. Blue | 722 Bray Blue |
| 089 Moss Green | 183 Moonlight Blue | 285 3/4 C.T. Orange | 724 Ocean Blue |
| 090 Dark Yellow Green | 184 Cosmetic Peach | 298 .15 ND | 725 Old Steel Blue |
| 100 Spring Yellow | 185 Cosmetic Burgundy | 299 1.2 ND | 728 Steel Green |
| 101 Yellow | 186 Cosmetic Silver Rose | 303 Pale Gold | 729 Scuba Blue |
| 102 Light Amber | 187 Cosmetic Rouge | 306 Medium Lemon | 730 Liberty Green |
| 103 Straw | 188 Cosmetic Highlight | 308 Medium Straw | 735 Velvet Green |
| 104 Deep Amber | 189 Cosmetic Silver Moss | 309 Special Straw | 738 Jas Green |
| 105 Orange | 190 Cosmetic Emerald | 311 Flame | 746 Brown |
| 106 Primary Red | 191 Cosmetic Aqua Blue | 313 Special Light Amber | 748 Seedy Pink |
| 107 Light Rose | 192 Flesh Pink | 315 Special Golden Amber | 750 Durham Frost |
| 108 English Rose | 193 Rosy Amber | 317 Dark Amber | 763 Wheat |
| 109 Light Salmon | 194 Surprise Pink | 321 Light Red | 764 Sun Color Straw |
| 110 Middle Rose | 195 Zenith Blue | 322 Soft Green | 765 Ultra Yellow |
| 111 Dark Pink | 196 True Blue | 323 Jade | 767 Oklahoma Yellow |
| 113 Magenta | 197 Alice Blue | 325 Mallard Green | 774 Soft Amber Key 1 |
| 115 Peacock Blue | 198 Palace Blue | 327 Forest Green | 775 Soft Amber Key 2 |
| 116 Medium Blue Green | 200 Double C.T. Blue | 328 Follies Pink | 776 Nectarine |
| 117 Steel Blue | 201 Full C.T. Blue | 332 Rose Pink | 777 Rust |
| 118 Light Blue | 202 1/2 C.T. Blue | 339 Rose Purple | 778 Millennium Gold |
| 119 Dark Blue | 203 1/4 C.T. Blue | 340 Surprise Lavender | 779 Bastard Pink |
| 120 Deep Blue | 204 Full C.T. Orange | 341 Plum | 781 Terry Red |
| 121 Evergreen | 205 1/2 C.T. Orange | 342 Special Lavender | 789 Blood Red |
| 122 Fern Green | 206 1/4 C.T. Orange | 343 Medium Lavender | 790 Moroccan Pink |
| 124 Dark Green | 207 C.T. Orange + .3ND | 344 Violet | 791 Moroccan Frost |
| 126 Mauve | 208 C.T. Orange + .6ND | 345 Fuchsia Pink | 793 Vanity Fair |
| 127 Smoky Pink | 209 .3 Neutral Density | 349 Pale Blue | 794 Pretty 'N Pink |
| 128 Bright Pink | 210 .6 Neutral Density | 350 No Color Blue | 795 Magical Magenta |
| 129 Heavy Frost | 211 .9 Neutral Density | 352 Glacier Blue | 797 Deep Purple |
| 130 Clear | 212 L.C.T. Yellow | 353 Lighter Blue | 798 Chrysalis Pink |
| 131 Marine Blue | 213 White Flame Green | 354 Special Steel Blue | F.1 Frost F.1 |
| | 214 Full Tuff Spun Weave | 357 Special Medium Blue | F.2 Frost F.2 |
| | 215 1/2 Tuff Spun Weave | 360 Bright Blue | F.3 Frost F.3 |
| | 216 White Diffusion | 361 Surprise Blue | SWATCHBOOK |
| | 217 Blue Diffusion | | |

Fluorescent Tube Covers

UG-TUBE#-##XX

Colored fluorescent tube guards come in several sizes, colors, and lengths. The tubes are constructed of polycarbonate UV stable resins with a wall thickness of .017". The resins incorporate the color as they are not dyed. Two black end caps are included with each tube. Sold in cases of 24. **Sizes:** T8 diameter 1", T12 diameter 1.5" ■ **Lengths:** 48 inches, 96 inches ■ **Colors:** Clear, Amber, Blue, Green, Pink, Red, Purple, Yellow



UltraGel is also available in pre-cut Color Pack selections:

A: Red, Yellow, Green, Blue.

B: Amber, Turquoise, Mauve, Pink

Sizes: Par 46: 7"x7" ■ Par 56: 8"x8" ■ Par 64: 9"x9"

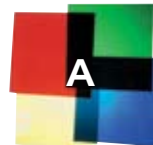

UltraGel

Light Shaping Diffusion



Light Shaping Diffusion (LSD) is a complete line of film lenses which are able to optically alter the output beam shape of any light source in varying degrees of diffusion strengths and profiles. Ranging from mild to strong diffusion, symmetric, and asymmetric beam control, LSD can be used as an accessory in many applications where precise light control shaping is desired. Using these highly efficient films you can manipulate the output distribution with a circular (symmetric) or elliptical (asymmetric) profile.

These diffusion films will increase luminance uniformity and help eliminate LED "hotspotting" and dark regions with minimal light loss. LSD films are particularly effective when color mixing RGB LEDs or multiple bins of the same color LED, producing . Use these films to create a consistent color output that improves fixture aesthetics. Due to unique optical characteristics, diffusion films are an efficient way to "hide" point light sources, and other bulbs. LSD lenses can also be known and called holographic film.

General Features:

- Variety shaping degrees: 10, 20, 30, 40, 50, 60, 100, 10x30, 60x1
- Eliminates hotspots
- Produces a more homogenous LED color blending
- Helps reduce glare from LED unit lenses
- Minimal light loss, up to 93% efficient
- Easy to use and cut
- Various flexible polymer materials
- UV stable
- Cleanable with Windex™
- Moderate heat tolerance for LED and Fluorescent light sources
- Supplied in 12" width by any length but sold in small 1 inch linear increments

UG-LSD1010

Specifications: 10 x 10 degree symmetrical beam spread ■ Base Material: PET ■ Transmission: 91% ■ Finish Gloss: High ■ Thickness: 2.4 mils ■ Typical operating range: -30 to +80 degree celcius ■ Roll Size: 12" wide ■ Sold by the linear inch (each is 12" x 1" increments)

UG-LSD1030

Specifications: 10 x 30 degree symmetrical beam spread ■ Base Material: PC ■ Transmission: 89% ■ Finish Gloss: High ■ Thickness: 9.06 mils ■ Typical operating range: -30 to +80 degree celcius ■ Roll Size: 12" wide ■ Sold by the linear inch (each is 12" x 1" increments)

UG-LSD2020

Specifications: 20 x 20 degree symmetrical beam spread ■ Base Material: PC ■ Transmission: 91% ■ Finish Gloss: High ■ Thickness: 3.94 mils ■ Typical operating range: -30 to +80 degree celcius ■ Roll Size: 12" wide ■ Sold by the linear inch (each is 12" x 1" increments)

UG-LSD4040

Specifications: 40 x 40 degree symmetrical beam spread ■ Base Material: PC ■ Transmission: 93% ■ Finish Gloss: High ■ Thickness: 7.28 mils ■ Typical operating range: -30 to +80 degree celcius ■ Roll Size: 12" wide ■ Sold by the linear inch (each is 12" x 1" increments)

UG-LSD6001

Specifications: 60 x 1 degree asymmetrical beam spread ■ Base Material: PC ■ Transmission: 82% ■ Finish Gloss: High ■ Thickness: 3.35 mils ■ Typical operating range: -30 to +80 degree celcius ■ Roll Size: 12" wide ■ Sold by the linear inch (each is 12" x 1" increments)

UG-LSD6060

Specifications: 60 x 60 degree symmetrical beam spread ■ Base Material: PC ■ Transmission: 89% ■ Finish Gloss: Low ■ Thickness: 11.81 mils ■ Typical operating range: -30 to +80 degree celcius ■ Roll Size: 12" wide ■ Sold by the linear inch (each is 12" x 1" increments)

Specifications are subject to change without notice.

TIE WRAPS

Cable tie wraps made of Nylon 66. Also known as plastic zip ties. UL Approved ■ Color: Black or Natural



Code	Description	Tensile Strength	Pack Size
TIEWRAP04B	4" Black	18 Lbs	100
TIEWRAP06B	6" Black	40 Lbs	100
TIEWRAP08B	8" Black	50 Lbs	100
TIEWRAP11B	11" Black	50 Lbs	100
TIEWRAP14B	14.5" Black	50 Lbs	100
TIEWRAP04N	4" Natural	18 Lbs	100
TIEWRAP06N	6" Natural	40 Lbs	100
TIEWRAP08N	8" Natural	50 Lbs	100
TIEWRAP11N	11" Natural	50 Lbs	100
TIEWRAP14N	14.5" Natural	50 Lbs	100

TIE LINE

High strength tieline, also known as trick line, for curtain fastening and cable wrapping. Diamond braided cotton, black matte. Size: #4 (1/8" diameter)



- TIELINE600** - 600 feet unglazed/uncoated
- TIELINE600C** - 600 feet glazed/coated
- TIELINE3000** - 3,000 feet unglazed/uncoated
- TIELINE3000C** - 3,000 feet glazed/coated

DURACELL PROCELL BATTERIES



Industry professionals prefer and only use PROCELL. If your show or event depends on a reliable and long lasting battery then PROCELL is the clear choice for a consistent performance. Sold in inner packs, packs and cases.

Code:	Battery Description	Pack Sizes
BAT-123PRO	3v Lithium 123A	6 / 24
BAT-4ACOP	AAAA 1.5v Copper Top 2 pack	2 / 12 / 48
BAT-6VCOP	6v Copper 908 Square Lantern Type w/Spring Terminals	6
BAT-9VPRO	9V Pro-Cell	12 / 72 / 288
BAT-AAAPRO	AAA 1.5v Pro-Cell	4 / 24 / 72
BAT-AAPRO	AA 1.5v Pro-Cell	4 / 24 / 144 / 576
BAT-CPRO	C 1.5v Pro-Cell	12 / 72
BAT-DPRO	D 1.5v Pro-Cell	12 / 72

Replacement Lamps and Bulbs

Techni-Lux stocks over 7,000 types of specialty and general lighting bulbs from low wattages to 20,000 watts. For all industries including theaters, night clubs, stage/studio, television, commercial, medical, video and cinema projection.

Bulb types include: Xenon ■ Metal Halide and High Intensity Discharge (HID) ■ Incandescent ■ Fluorescent ■ Compact Fluorescent ■ Halogen ■ Miniature ■ Sealed Beam/Par ■ Xenon Flash Strobe Tube ■ LED



Visit our website www.techni-lux.com
Request our Replacement Lamp Catalog or download your own PDF copy!

TAPES

Get the right tape for the right job. All specialty tapes have unique properties. Offered in various grades, sizes, and colors.

- **Gaff tape** is engineered to be removed and not leave adhesive residue on cables or surfaces. It is normally cloth based and offered in many colors. Its non-reflective matte properties make it useful on dark stages, photo shoots and curtains. Water resistant, high temperature and weather resistant.
- **Stage tape** is an economical version of gaff tape. It features the same adhesive backing and is matte finish.
- **Console or board tape**, also known as artist tape, is used for labeling control boards. It features a special adhesive that will pull away from your audio or lighting console at time of removal.
- **Paper tape** professional photo masking tape
- **Duct tape** (commercial grade) is a vinyl based tape with a normal adhesive.
- **Double sided tape** is mainly used on convention and trade show floors for attaching carpet. Cloth type pulls off easier at removal time and leaves no residue.
- **Electrical tape** U.L. listed electrical tape
- **Glow tape** is used for stage marking and outlining. It phosphoresces after 30 seconds of light exposure. Brightest for initial 30 minutes and remains visible in dark areas for up to 8 hours.
- **Caution tape** features diagonal black and yellow lines to OSHA standards. Used on stage steps and to mark danger areas. Vinyl material with standard adhesive.
- **Gel repair tape** Heat resistant clear tape to repair torn gels
- **Black matte wrap** is used for covering and masking off light.

PRO-GAFF TAPE

- TAPE-GAFF12FLGR** Gaff/Spike 1/2"x50 yds Fluorescent Green
- TAPE-GAFF12FLYE** Gaff/Spike 1/2"x50 yds Fluorescent Yellow
- TAPE-GAFF12FLOR** Gaff/Spike 1/2"x50 yds Fluorescent Orange
- TAPE-GAFF12FLPK** Gaff/Spike 1/2"x50 yds Fluorescent Pink
- TAPE-GAFF12RD** Gaff/Spike 1/2"x50 yds Red
- TAPE-GAFF12WH** Gaff/Spike 1/2"x50 yds White
- TAPE-GAFF12YE** Gaff/Spike 1/2"x50 yds Yellow

- TAPE-GAFF1BK** Gaff 1"x60 yds Black
- TAPE-GAFF1WH** Gaff 1"x60 yds White
- TAPE-GAFF2BK** Gaff 2"x60 yds Black
- TAPE-GAFF2BR** Gaff 2"x60 yds Brown
- TAPE-GAFF2RD** Gaff 2"x60 yds Red
- TAPE-GAFF2GY** Gaff 2"x60 yds Gray
- TAPE-GAFF2WH** Gaff 2"x60 yds White
- TAPE-GAFF2EBL** Gaff 2"x60 yds Electric Blue
- TAPE-GAFF2LB** Gaff 2"x60 yds Light Blue
- TAPE-GAFF2TE** Gaff 2"x60 yds Teal
- TAPE-GAFF2LG** Gaff 2"x60 yds Light Green
- TAPE-GAFF2OL** Gaff 2"x60 yds Olive

- TAPE-GAFF2FLGR** Gaff 2"x50 yds Fluorescent Green
- TAPE-GAFF2FLYE** Gaff 2"x50 yds Fluorescent Yellow
- TAPE-GAFF2FLOR** Gaff 2"x50 yds Fluorescent Orange
- TAPE-GAFF2FLPK** Gaff 2"x50 yds Fluorescent Pink

- TAPE-GAFF3BK** Gaff 3"x60 yds Black
- TAPE-GAFF3GY** Gaff 3"x60 yds Gray
- TAPE-GAFF3WH** Gaff 3"x60 yds White
- TAPE-GAFF3BY** Gaff 3"x60 yds Burgundy
- TAPE-GAFF3FLOR** Gaff 3"x50 yds Fluorescent Orange

- TAPE-GAFF4BK** Gaff 4"x60 yds Black
- TAPE-GAFF4GY** Gaff 4"x60 yds Gray

- TAPE-CABLEYE4** Cable Path Yellow 4"x30 yds

PERMACEL GAFF

- TAPE-GAFF2BKP** P-665 Gaff 2"x60 yds Black
- TAPE-GAFF2WHP** P-665 Gaff 2"x60 yds White
- TAPE-GAFF2GRP** P-665 Gaff 2"x60 yds Green



GEL REPAIR TAPE - Clear

- TAPE-JLAR1** Gel Repair Tape 1"x72 yds
- TAPE-JLAR2** Gel Repair Tape 2"x72 yds

DUCT TAPE

- TAPE-DUCT2BK** Duct 2"x60 yds Black
- TAPE-DUCT2GY** Duct 2"x60 yds Gray/Silver
- TAPE-DUCT2BY** Duct 2"x60 yds Burgundy
- TAPE-DUCT2BR** Duct 2"x60 yds Brown

CONSOLE/BOARD/PAPER TAPE

- TAPE-BOARD12WH** Board 1/2"x60 yds White
- TAPE-BOARD34WH** Board 3/4"x60 yds White
- TAPE-BOARD1WH** Board 1"x60 yds White
- TAPE-PAPER1BK** Paper 1"x60 yds Black
- TAPE-PAPER2BK** Paper 2"x60 yds Black

CARPET TAPE - Double Sided (two sided)

- TAPE-DOUBLE1** Double 1"x30 yds
- TAPE-DOUBLE2** Double 2"x30 yds

ELECTRICAL TAPE

- TAPE-ELEC34BK** Elec. U.L. 3/4"x66 Ft Black
- TAPE-ELEC34BL** Elec. U.L. 3/4"x66 Ft Blue
- TAPE-ELEC34BR** Elec. U.L. 3/4"x66 Ft Brown
- TAPE-ELEC34GR** Elec. U.L. 3/4"x66 Ft Green
- TAPE-ELEC34GY** Elec. U.L. 3/4"x66 Ft Gray
- TAPE-ELEC34OR** Elec. U.L. 3/4"x66 Ft Orange
- TAPE-ELEC34PU** Elec. U.L. 3/4"x66 Ft Purple
- TAPE-ELEC34RD** Elec. U.L. 3/4"x66 Ft Red
- TAPE-ELEC34WH** Elec. U.L. 3/4"x66 Ft White
- TAPE-ELEC34YE** Elec. U.L. 3/4"x66 Ft Yellow

GLOW TAPE

- TAPE-GLOW1-10** Glow 1"x10 yds
- TAPE-GLOW12-10** Glow 1/2"x10 yds
- TAPE-GLOW2-10** Glow 2"x10 yds

CAUTION TAPE

- TAPE-STRIFE2YB** 2"x30 yds Stripe Yellow/Black
- TAPE-STRIFE3YB** 3"x18 yds Stripe Yellow/Black

BLACK MATTE WRAP - No adhesive

- TAPE-WRAPBLK12** Matte wrap 12"x50' Black
- TAPE-WRAPBLK24** Matte wrap 24"x25' Black

STAGE - ECONOMY GAFF - MATTE FINISH

Stage tape is an economical version of gaff tape. It features the same adhesive backing and is matte finish.

- TAPE-STAGE2BK** Stage 2"x60 yds Black
- TAPE-STAGE4BK** Stage 4"x60 yds Black

Specifications are subject to change without notice.

COLOR MOON
EL-COLORMOON/D

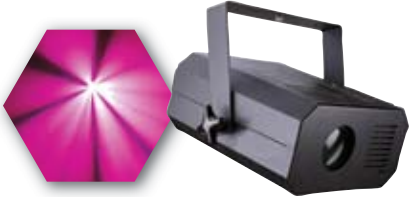

The Color Moon sets the standard. Sharp beams and rich dichroic colors rotate back and forth making this the best moon flower effect ever. Its new synchronization feature makes it even more spectacular when used in multiples. Uses precision stepping motor and 8 dichroic filters. Linkable in master/slave mode to the beat of the music or by DMX control.

Specifications: ENH 250w 120v Lamp ■ Power: 120v-50/60Hz ■ Current draw: 2.5 Amps ■ 3-Pin XLR input for DMX ■ Size: 13.8"x8.7"x7.9" ■ Weight: 9Kgs/20Lbs

STARLIGHT
EL-STARLIGHT
Clear lenses
EL-STARLIGHT/C
Colored lenses

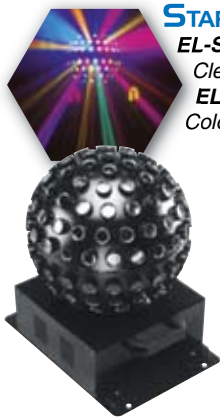

Impressive mirror ball type effect. Great for slow music dancing and disco type lighting. Excellent for larger venues, such as skating rinks. Projects focused multiple beams of colored light while it slowly rotates.

Specifications: Lamp 64514 300w 120v ■ Power: 120v-50/60Hz ■ Current draw: 3 Amps ■ Size: 14"x10"x10" ■ Weight: 7.5Kgs/16.5Lbs



ALPHA
EL-SRL402

An impressive centerpiece in its price range is the ALPHA. Eight powerful beams are disbursed from only one inexpensive lamp. This favorite effect fills any room with a multitude of colored light shafts which dance back and forth to the music.

Specifications: EVC 250w 24v Lamp ■ Sound Activation with Sensitivity Adjustment ■ Fan Cooling ■ Power: 120v-50/60Hz ■ Current draw: 4 Amps ■ Size: 15.7"x20.9"x20.9" ■ Weight: 16Kg/35.2Lbs.

TRILLY
EL-ML414-ML

The Trilly is a multi-colored moon-flower effect. The multiple strokes of sharp light rotate back and forth to the sound of the music. This cool effect can be used singularly or in multiples. Features Italian grade optics and aluminum extruded body.

Specifications: FCS 150w 24v lamp ■ Built in self adjusting audio microphone ■ Power: 120v-50/60Hz ■ Current draw: 2 Amps ■ Size: 12"x8"x7.5" ■ Weight: 6.4Kgs/14Lbs

TUNNEL BEAM
EL-SRL436

The enticing TUNNEL BEAM creates a high speed laser like effect. A rotating wheel provides four changing colors. This distinct effect is also sound active and uses an inexpensive and powerful 300 watt lamp.

Specifications: 64514 300w 120v Lamp ■ Sound Activation with Sensitivity Adjustment ■ Fan cooling ■ Power: 120v-50/60Hz ■ Current draw: 3 Amps ■ Size: 13"x7.5"x6" ■ Weight: 4.3Kgs/9.5Lbs

OCEAN
EL-ES110-LA

This unique lighting fixture produces a tranquil effect simulating the waves of the ocean. Using a special "S" shaped lamp, light projects through clear lenses which you can gel for your particular color effect. The wave effect is continuous. Best experienced when used with haze or light fog mist.

Specifications: Lamp LLP82 800w ■ Continuous rotation ■ Fan cooled ■ Power 230v-50/60Hz ■ Current draw: 5 Amps ■ Size: 14.5"x16.9"x13.4" ■ Weight: 8Kgs/17.6Lbs

STEADY KALIMA
EL-ES15/SK-LA

Fixed light unit that creates a fan of light tunnels thanks to its special lamp. Can create solid shafts using a different lamp also. Colored lenses available on request. Use 120v or 230v HX185 800w lamp for tunnel beams effect.

Specifications: Lamp HX185 800w ■ Power: 230v or 120v 50/60Hz ■ Current draw: 4 Amps ■ Size: 11.2"x16.9"x13.4" ■ Weight: 5.5Kgs/12.1Lbs

MICROUFO
EL-MICROUFO

It's a baby spinning saucer! 8 colored-flat beams spin around and out of the bottom shoots a colored moonflower. Great for bars, party supply stores and mobile DJs who want something which is compact and effective.

Specifications: 64514 300w 120v ■ Power: 120v-50/60Hz ■ Current draw: 3.5 Amps ■ Size: 8.5"x8.5"x11" ■ Weight: 3.2Kgs/ 7Lbs

BEACONS

Great for mobile and permanent installations, the police beacons are a novelty hard to pass up. The spinning beam is a great attention getter especially in store fronts. Two sizes and three different colors are available. X in order code represents Red, Blue and Amber.

EL-BEACON1X Lamp: 75w 120v E27 ■ Size: 8.6"x8.6"x9." ■ Weight: 2.5Kgs/ 5.5Lbs

EL-BEACON2X Lamp: 25T8DC 25w 120v ■ Size: 5.7"x5.7"x7.1" ■ Weight: 1.5Kgs/3.3Lbs

Specifications are subject to change without notice.

COLOR MIRAGE
EL-COLOMIRAGE

Color Mirage creates a dreamy state of color. Simulates the reflection of light from water. Two modes are available: continuous color change rotation or static color. Static color may be set to one solid color or a bi-color effect as shown in picture above. Uses 6 dichroic colors. Manually focusable lens. Includes adjustable mounting bracket with 1/2" hole in center for clamp mounting.

Specifications: ELC 250w 24v Lamp ■ Fan Cooling ■ 6 dichroic colors ■ Power: 120v-50/60Hz ■ Current draw: 3 Amps ■ Size: 10"x10"x7" ■ Weight: 6.6Kgs/14.5Lbs



KALEIDOSCOPE
EL-KALEIDO2

A very bright and colorful kaleidoscope lighting effect using the popular and powerful ENH MR-16 250w 120v lamp source, the same lamp used in professional color changers. Projects a beam through a rotating glass prism filled with many colorful pieces of dichroic glass. Prism can also rotate by selecting on/off switch in back of the unit. Adjustable focus lens.

Specifications: ENH 250w 120v MR-16 ■ Fan Cooling ■ Power: 120v-50/60Hz ■ Current Draw: 3 Amps ■ Size: 12"x9.5"x7" ■ Weight: 3.4Kgs/7.5Lbs



SPACEFLOWER
EL-SPACEFLOW3

SpaceFlower is an outdoor multi-ray aerial effect light fixture. Its spectacular effect is created by the opening and closing of three circles of 12 rays each. The version with DMX and shutter even makes it useful for large stage and show performances.

Specifications: Lamp: STI 3000w ■ Visibility: approximately 7 kilometers ■ Thermal protection ■ Pan 150 degrees ■ Shutter ■ Rotation, open and closing of 3 circles of rays ■ Controllable via DMX using 6 channels: 1-Pan Speed, 2-Flowers, 3-Ray Rotation, 4-Shutter, 5-Pan, 6-Aux ■ Power: 220v-50/60Hz ■ Size: 27"x17.7"x30.4" ■ Weight: 50Kgs/110Lbs ■ Weather resistant case



DOUBLE DERBY/D
EL-DDERBY/D

Like the traditional Double Derby but better! Creates 40 intense multi-colored beams which criss-cross back and forth to the music. Very bright effect ideal for entertainment venues and mobiles who want total show control. Units are linkable in master/ slave mode or via DMX. Two DMX channels allow control of motor and lamp on/off.

Specifications: Lamp: 2x 120v/300w 64514 ■ Sound activation ■ Fan cooling ■ Power: 120v-50/60Hz ■ Current draw: 6 Amps ■ 3-Pin XLR input ■ Size: 17"x15"x11" ■ Weight: 10Kgs/ 22Lbs



DERBY/D
EL-DERBY/D

The linkable Derby/D brings control to the most famous effect ever. Emits 20 intense multi-colored beams which cross back and forth to the beat of the music or by DMX control. Also, features a master/slave mode for multiple synchronization. Two DMX channels allow control of motor and lamp on/off.

Specifications: Lamp: 2x 120v/300w 64514 ■ Sound Activation ■ Fan Cooling ■ Power 120v-50/60Hz ■ Current draw: 6 Amps ■ 3-Pin XLR input ■ Size: 17"x15"x11" ■ Weight: 8Kgs/ 17.6Lbs



DOMINATOR
EL-DOMINATOR/D

Dominator is an outdoor multi-ray aerial effect light fixture. At 6600 watts, the Dominator is absolutely the most powerful outdoor multiray effect on the market today! Its spectacular effect is created by the opening and closing of three circles of 12 rays each. Control it using standard DMX512.

Specifications: Lamp: HMD6600 6600w ■ Visibility: approximately 11 kilometers ■ Thermal protection ■ Pan 150 degrees ■ Rotation, open and closing of 3 circles of rays ■ DMX 6 channels: 1-Pan Speed, 2-Flowers, 3-Ray Rotation, 4-Aux, 5-Pan, 6-Aux ■ Power: 220v-50/60Hz ■ Size: 40"x18"x35.8" ■ Weight: 65Kgs/143Lbs ■ Weather resistant case



GOBLIN
EL-GOBLIN

Projects multi colored flats blades that rotate to the music back and forth. Light-weight and great for mobile or permanent installations. Long lasting economical lamp.

Specifications: Lamp EHM 300w 120v R7s ■ Sound Activation with Sensitivity Adjustment ■ Fan cooling ■ Power: 120v-50/60Hz ■ Current draw: 3 Amps ■ Size: 13"x14"x8" ■ Weight: 6.8Kgs/15lbs



MUSHROOM/D
EL-MUSHROOM/D

Projects multi-colored beams that criss-cross back and forth and rotate. This fixture ranks in the Top 5 DJ favorites. It is light weight and features an internal microphone for sound to light activation or can be controlled via DMX.

Specifications: 2x 64514 300w 120v Lamp ■ Sound Activation or DMX512 ■ Fan cooling ■ Power: 120v-50/60Hz ■ Current draw: 6 Amps ■ 3-Pin XLR DMX input ■ Size: 14"x10.5"x10.5" ■ Weight: 3.4Kgs/7.5Lbs



Specifications are subject to change without notice.



BlissLights™ are simple to use lighting-effect projectors that create an explosion of thousands of moving pin-points of light. They move on unique far-reaching trajectories complete with an ever-transforming nebula cloud that stimulates the imagination.

BlissLights™ incorporate laser and optical elements to create a breathtaking lighting effect much like a universe of moving stars. BlissLights™ creates paintings out of light that must be experienced with your own eyes to appreciate the fine attention to detail in each work of art.

BlissLights™ are designed for commercial and homeowner applications. Lighting industry professionals use BlissLights™ to illuminate hard-to-light areas and create a unique lighting experience never-before-seen which is sure to impress their clients. Everyday consumers want to amaze their family and friends by transforming their homes or backyards into a magical, starry experience.

BlissLights™ brings forth a new lighting experience that creates a new standard in the indoor and outdoor lighting industries.

BlissLights™ LSA20G SERIES

OUTDOOR ARCHITECTURAL LIGHTING

AL-LSA20G-B Architectural Bronze Finish

AL-LSA20G-C Copper Finish

Perfect for garden and outdoor magical lighting!

BlissLights™ LSA20 Series projectors utilize architectural style lighting fixtures to house the magical BlissLight effect. The technology incorporates laser and holographic optical elements.

Point it toward trees and bushes and watch outdoor landscapes immediately come alive with thousands of twinkling lights. Contractors, lighting designers and landscape architects can transform landscapes into a fantasyland. Homeowners use BlissLights™ to amaze their families and friends by transforming the outsides of their homes and backyards into a truly magical experience.

- Easy to install, the light is projected
- Generates and projects thousands of pin-points of light
- Patented holographic laser technology
- Weather resistant for outdoor use
- Transforms dark areas into a unique animated universe
- Features 2 built-in precision glass lenses
- Creates a one-of-a kind lighting experience

Specifications: Laser Classification FLPPS Class IIIa ■ Maximum Laser Power (Single Beam) Less than 5 mw ■ Laser Wavelength 532 nm - Green ■ Laser MTBF More than 7000 hours ■ Laser Optics Single source holographic optical element ■ Power Consumption 10 watts ■ Power Input 12 VAC ■ Operation Indoor/Outdoor ■ Operating Temperature 5°C to 30°C (40°F to 86°F) ■ Projection Coverage 25 ft. x 25 ft. ■ 2.5 ft. of coverage for every 1 ft. of throw ■ Maintenance-free ■ UL Listed ■ Size: 14.25"x4.5"x3.75" ■ Warranty 1 Year



BlissLights™ LASERWAND

AL-BLH5G

Project a Universe of Stars from the palm of your hand! Works in the smallest room to the largest warehouse.



Specifications: FLPPS Class 2 Laser Classification ■ Total Laser Power Less than 5mw ■ Single Laser Beam Less than 1mw ■ Laser MTBF More than 1,000 hours ■ Laser Optics High diffraction efficiency digital holographic optical element ■ Power Source CR123A Battery ■ Coverage Rooms BIG and small ■ Dimensions 4"x0.75" Diameter ■ Warranty 90 days

BlissLights™ AL-BL15G

INDOOR PROJECTION LIGHTING

The BlissLights™ 15 is the smaller and economical version of The BlissLights™ 50 with lighting elements and holographic optical lenses that generate thousands of pin points of light which create an enormous "universe of stars" that will amaze everyone.

The BlissLights™ 15 is designed for commercial and homeowner applications. The BlissLights™ 15 is used by Architectural Lighting professionals, Interior Designers, Lighting Designers, Contractors, Event Planners, Entertainment Lighting companies, Amusement Parks, Homeowners, Home Theatre enthusiasts, just to name a few. BlissLights brings forth a new lighting experience that creates a new standard in the lighting industry.

The BlissLights™ 15 uses a 15 mw laser module and is perfect for smaller spaces and hard-to-light areas. The BlissLights™ 15 has a rugged construction, a multi-position mounting system, fan-less temperature regulation systems, and a built-in power regulator that is an engineering marvel. When combined with the lighting and optics, you get the BlissLights™ 15, a product that is incredibly ahead of its time.



- Easy to install and simple to use: just plug it in
- Generates and projects thousands of pin-points of light
- Patent-pending holographic laser technology
- Transforms dark areas into a unique animated universe
- Features 2 built-in precision glass lenses
- Creates a one-of-a kind lighting experience

Specifications: FLPPS Class: IIIa Laser Classification ■ Maximum Laser Power (Single Beam) Less than 5 mw ■ Laser Wavelength 532 nm ■ Laser MTBF 7000+ hours ■ Laser Optics single source holographic optical element ■ Power Consumption 1 watt ■ LED Wavelength 455 nm ■ LED MTBF 100,000+ hours ■ Power Consumption 30 watts ■ Power Input 10 VAC ■ Plug and Play operation ■ Operating Temperature Less than 30°C or 86°F ■ Projection Coverage 25 ft. x 25 ft., 2.5 ft. of coverage for every 1 ft. of throw ■ Maintenance-free ■ UL Listed ■ Size: 4.4"x4.4"x7.4" ■ Weight: 3.6Kgs/8Lbs ■ 1 year warranty

Specifications are subject to change without notice.

Pro Sound & Electrical PROFESSIONAL SERVICES

Pro Sound & Electrical design services are available to assist with projects and individual show designs. Our on staff design team is able to provide over 50 years of design, studio and touring experience to help develop your vision. Utilizing a state of the art computer system and rendering farm provided by an exclusive partnership with Render Blender, a building or production can be brought to life and lights reviewed and tested months before installation.

Consultation, review and design services are available for any size project through our dealer network. We have helped many clients achieve their dream systems with savings on utilities and construction through proper design and consultation. The final product can be presented in working drawings, animations, photo quality renderings or slide shows. Our design staff is ready to help you, help yourself. Our clients have included Disney, Universal Studios, Wet 'n Wild to name a few. Call today and discuss your project dreams with us. For additional information call us at (407)468-3396



DVD Demo Avail

Design Services

Specifications are subject to change without notice.

DESIGN

We can help you with equipment selection, layout and coordination while guaranteeing that all of your needs are met through proper and efficient design. Whether you are working with a small community show or a full size building design we are available to assist you with Architectural, Retail, Club, Theatrical, Touring and House of Worship design services. Full consultation and project review services are also available to work with your team. We can also provide project specific control and automation systems fully customized and built by our engineering teams. A properly designed project will be easier to envision and sell and often saves money.

RENDERING & ANIMATION

PS & E is proud to be the exclusive provider of Render Blender, LLC. Through this partnership we can provide high quality animations and renderings of your project. Whether you need to see that camera shot or want to virtually walk through your concept, our animation services can make that happen. We can also work with and enhance your existing WYSIWYG drawing and then provide photo realistic renders of the lighting. We can provide drawings up to 36" x 48", pipe tapes, DVD quality animations and clean up services. Render Blender LLC is a Certified Service Provider (CSP) for Cast software.

SIMULATION SUITE & TRAINING

At our Orlando headquarters we offer a 400 square foot programming and training suite with fixtures and consoles. This space can be rented to help you pre-program a show before you are in the facility or before the site is available, saving thousands on time and rental fees. Consoles can be connected to a high speed computer which will project a wall sized image of the space in a real time lighting simulation. Training is offered for a complete line of lighting consoles and fixtures along with a library of lectures and seminars. An Authorized WYSIWYG Trainer (AWT) is on staff. Contact us about our upcoming class schedule.

PROGRAMMING

We have a team of programmers available to help with any size show or project. We have extensive experience in Theatrical, Architectural, Themed Attraction and Event programming for Theatres, Casino's, Cruise Ships, House of Worship and a variety of specialty venues. We can provide system layout, patching, fixture assignment, cueing, show dissemination, timecode and automation. Programming work can be done in our office, on-site or a combination of both. A lighting system and design is only as good as its execution and programming is a large part of the overall finished product.

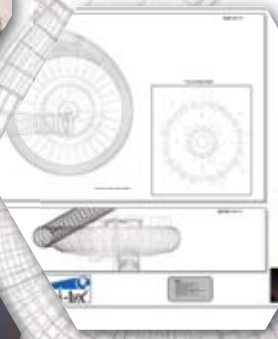

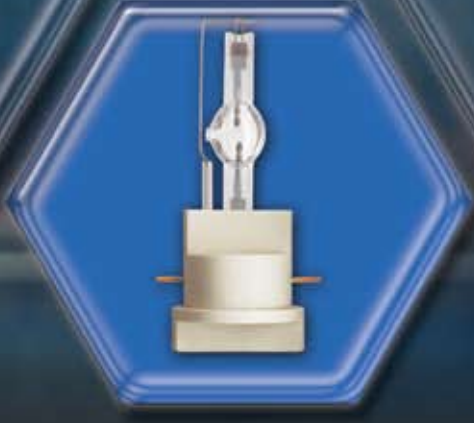
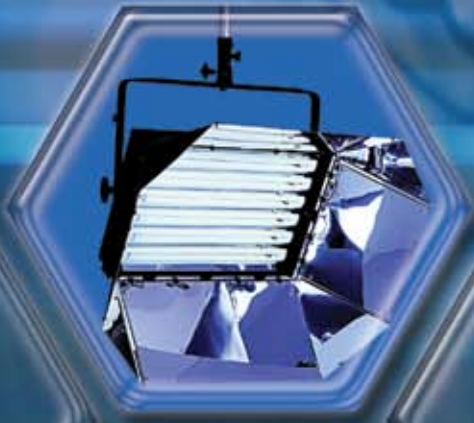

Pro Sound & Electrical - Licensed Electrical Contractor
Orlando, FL ■ U.S.A.
Phone: 407-468-3396 ■ Fax: 407-226-0194
www.prosoundelectrical.com

Copyright © 2009 Pro Sound & Electrical. All rights reserved.
Specifications subject to change without notice. Not responsible for typographical errors.

Rev 09.1